

CL108/CL208/CL308

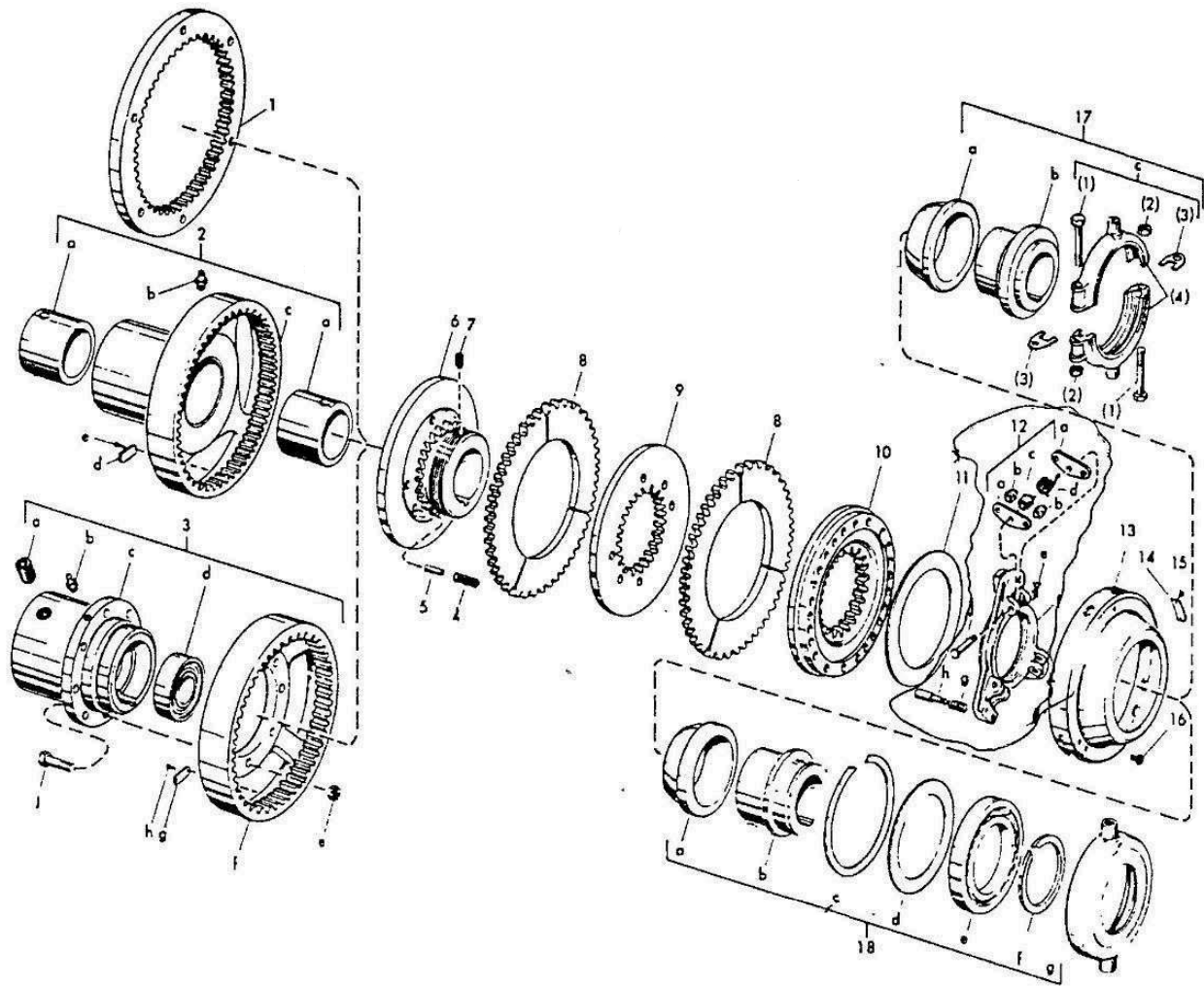

SPECIAL NOTES:

- (1) The above view shows a standard two plate (Item 8) model CL clutch. However, the part numbers listed in this bulletin cover all the various models including the one and three plate versions.
- (2) The above view shows three optional driving members for the model CL clutch. Item one is a standard driving ring that is adapted to other vendor supplied components. Items two or three are spider, hub combinations that are designed for a single (customer supplied) shaft arrangement as in item two, or a two shaft arrangement as in item three. The spider flange (item 3f) can also be purchased separately and used with a customer supplied hub.
- (3) The above view shows two different throwout collars; Item 17 and Item 18. The bronze (#17) collars are lower cost and have the advantage of being radially split for easy replacement. The ball bearing (#18) collars have longer life and are usually recommended where frequent engagements are necessary.
- (4) Model CL clutches can also be supplied with solid driving plates (in place of split plates), sintered iron bonded plates, metal core plates with frictions or special bolt-up (in place of gear tooth) friction type (single) plates. All these items must be specified on your Twin Disc (five digit) bill of material number and not be modified without proper recommendation.
- (5) The special non-overlocking cone ring (Item #17a and #18a) is optional and is specified in applications where positive (locked in) engagement is not required.

CL108 / CL208 / CL308

Item	Description	CL108	Qty	CL208	Qty	CL308	Qty
1.	Ring, Driving	CL5805	1	CL5796	1	CL6724	1
2.	Spider, Driving, Bushing Assembly	CLW110	1	CLW111	1	CLW112	1
a.	Bushing, Bronze	CLAI221	2	CLAI221	2	CLAI221	2
b.	Fitting, Hydraulic	CLM268	1	CLM268	1	CLM268	1
c.	Spider, Driving	CL8151 1B	1	CL8151 2B	1	CL8151 3B	1
3.	Spider, Driving, Ball Bearing Assembly	CLW113	1	CLW114	1	CLW115	1
a.	Setscrew, Cup-Point, Hex-Socket	CLM2043Q	1	CLM2043Q	1	CLM2043Q	1
b.	Fitting, Hydraulic	CLM268	1	CLM268	1	CLM268	1
c.	Hub, Ball Bearing Type	CLA5939	1	CLA5939	1	CLA5939	1
d.	Ball Bearing, Spider, Driving	CLM171	1	CLM171	1	CLM171	1
e.	Nut, Hex-Slotted	CLM1930F	8	CLM1930F	8	CLM1930F	8
f.	Flange, Spider, Driving	CLA5927	1	CLA5928	1	CLA5929	1
g.	Screw, Hex-Head Cap	CLM2002AK	8	CLM2002	8	CLM2002AK	8
4.	Spring, Release	CL1818	6	CL1930A	6	CL2011	6
5.	Pin, Spring, Release			CLM1927C	6	CLM1927D	6
6.	Plate, Hub and Back	CL6526	1	CL6528	1	CL6545	1
7.	Setscrew, Dog-Point, Half	CLM2039E	1	CLM2039E	1	CLM2039E	1
8.	Plate, Driving (Split) 51 Teeth	CL6479L	1	CL6479L	2	CL6479L	3
	Plate, Driving (Optional Solid) 51 Teeth	CL6479K	1	CL6479K	2	CL6479K	3
9.	Plate, Center			CL4633	1	CL4633	2
10.	Plate, Floating	CLA5388C	1	CLA5388C	1	CLA5388C	1
11.	Disc, Roller	CLA3649	1	CLA3649	1	CLA3649	1
12.	Yoke, Adjusting, Assembly	CLA211	1	CLA211	1	CLA211	1
a.	Lever	CLB3388	6	CLB3388	6	CLB3388	6
b.	Roller	CLB2189	6	CLB2189	6	CLB2189	6
c.	Spacer	CLA2798DM	3	CLA2798DM	3	CLA2798DM	3
d.	Spring, Lever	CLA2603	3	CLA2603	3	CLA2603	3
e.	Cotter Pin	CLB1535C	3	CLB1535C	3	CLB1535C	3
f.	Yoke, Adjusting	CLA3747D	1	CLA3747D	1	CLA3747D	1
g.	Spring, Pin Lock, Adjusting	CL1382	1	CL1382	1	CL1382	1
h.	Pin, Lock, Adjusting	CLA1683	1	CLA1683	1	CLA1683	1
i.	Pin, Lever	CLB1538E	3	CLB1538E	3	CLB1538E	3
13.	Cover, Clutch	CLA3762	1	CLA3762	1	CLA3762	1
14.	Plate, Specification, Clutch	CLA2012	1	CLA2012	1	CLA2012	1
15.	Pin, Drive	CL1333	2	CL1333	2	CL1333	2
16.	Screw, Machine, Round-Head	CLM2023F	3	CLM2023F	3	CLM2023F	3
17.	Cone, Bronze, Assembly						
a.	Cone, Ring	CLA3469	1	CLA3469	1	CLA3469	1
	Cone, Ring (Non-Overlocking)	CLZA3469A	1	CLZA3469A	1	CLZA3469A	1
	Cone, Ring (Non-Overlocking)	CLZA3469C	1	CLZA3469C	1	CLZA3469C	1
b.	Sleeve, Cone	CLA3471	1	CLA3471	1	CLA3471	1
c.	Collar, Cone, Bronze Assby.	CLX117C10	1	CLX117C10	1	CLX117C10	1
	(1) Screw, Hex-Head	CLM2002BB	2	CLM2002BB	2	CLM2002BB	2
	(2) Nut, Lock, Hex	CLM1930F	2	CLM1930F	2	CLM1930F	2
	(3) Shim, Collar	CL1294	2	CL1294	2	CL1294	2
	(4) Collar, Cone, Split	CL117C10	1	CL117C10	1	CL117C10	1
18.	Cone, Ball Bearing, Assembly						
a.	Cone, Ring	CLA3469	1	CLA3469	1	CLA3469	1
	Cone, Ring (Non-Overlocking)	CLZA3469A	1	CLZA3469A	1	CLZA3469A	1
	Cone, Ring (Non-Overlocking)	CLZA3469C	1	CLZA3469C	1	CLZA3469C	1
b.	Sleeve, Cone	CLA3552	2	CLA3552	1	CLA3552	1
c.	Ring, Snap, Collar Cone	CLA2669K	1	CLA2669K	1	CLA2669K	1
d.	Washer, Cone Collar	CLA1366	1	CLA1366	1	CLA1366	1
e.	Ball Bearing, Cone Collar	CLM281	1	CLM281	1	CLM281	1
f.	Ring, Snap, Cone Sleeve	CLA2622H	1	CLA2622H	1	CLA2622H	1
g.	Collar, Cone, Ball Bearing	CL4852	1	CL4852	1	CL4852	1