

GARDNER-DENVER®

3-526

1st Edition

FXX__B

8" STROKE

DUPLEX POWER PUMP

**NDS Drilling Supply, Inc
26041 Newton Circle
Elko New Market, MN 55020
(800) 637-1940**

PARTS LIST

**COOPER**

**Gardner-Denver
Industrial Machinery**

**MINI-MATRIX FOR
MODEL "FXX" 8" STROKE DUPLEX POWER PUMP
ELEVEN (11) CHARACTER MODEL DESIGNATIONS**

NOTICE TO CUSTOMER - To find the construction options for your pump unit, FILL IN THE BALANCE OF LETTERS OR NUMBERS FROM YOUR UNIT NAMEPLATE
COLUMN NUMBER:

F	X	X			B					
1	2	3	4	5	6	7	8	9	10	11

FOLLOW THE LINE DOWN AND OVER FROM EACH SPACE THUS FILLED IN TO FIND THE APPROPRIATE CONSTRUCTION OPTION WITH WHICH YOUR MACHINE IS EQUIPPED. THE NUMBER "9" IN ANY COLUMN SPACE INDICATES "NOT APPLICABLE." THE NUMBER "8" IN ANY COLUMN SPACE INDICATES SPECIAL DESIGN -- REFER TO FACTORY ORDER TICKET.

COLUMNS 1, 2 & 3 - BASIC FAMILY

COLUMN 4 - TYPE SERVICE

	MASTER CYL SIZE & CONSTRUCTION			
	7-1/2" 2pc Cast Iron	5-1/2" 1pc Cast Iron	5" 1pc Cast Iron	5" 2pc Cast Steel
Slush	A	B	C	D
Grout & Cement	E	F	G	H
Oil	J	K	L	M
Water	N		P	Q
General	R	S	T	U

COLUMN 5 - SIZE SELECTIVE

	(MASTER SIZE)		(MASTER SIZE)
A - 7-1/2"	(7-1/2")	G - 5-1/2"	(7-1/2" & 5-1/2")
B - 7-1/4"	(7-1/2")	H - 5"	(7-1/2", 5-1/2" & 5")
C - 7"	(7-1/2")	J - 4-1/2"	(5-1/2" & 5")
D - 6-3/4"	(7-1/2")	K - 4"	(5-1/2" & 5")
E - 6-1/2"	(7-1/2")	L - 3-1/2"	(5-1/2" & 5")
F - 6"	(7-1/2")	M - 3"	(5")

COLUMN 6 - DESIGN VERSION

COLUMN 7 - LINER MATERIAL SELECTIVE

- A. Bronze - Standard for Water Service
- B. Hardened Steel - Standard for Slush, Grout & Cement, Oil and General Service
- C. Stainless Steel - Optional

COLUMN 8 - PISTON TYPE SELECTIVE

- A. Bronze - Follower Type w/Regular Cure Packing (Std. for Water Service)
- B. Bronze - Follower Type w/Rock Hard Packing (Optional for Water Service)
- C. Iron - Follower Type w/Regular Cure Packing (Std. for General Service)
- D. Iron - Follower Type w/Rock Hard Packing (Optional for General Service)
- E. Iron - Solid Type w/Cast Iron Rings (Std. for Oil Service)
- F. Steel - Insert Type (Std. for Slush and Grout & Cement Service)
- G. Bronze - Cup Type (Optional)
- H. Iron - Cup Type (Optional)
- J. Steel - Cup Type (Optional)

COLUMN 9 - PISTON ROD MATERIAL & PACKING SELECTIVE

- A. Bronze Rod & Braided Asbestos Packing (Std. for Water Service)
- B. Hardened Steel Rod & Braided Asbestos Packing (Std. for Oil and General Service)
- C. Hardened Steel Rod & Molded Convex Packing (Std. for Slush or Grout & Cement Service)
- D. Hardened Steel Rod & Molded Rubber & Duck Packing (Optional)
- E. Chrome Plated Rod & Braided Asbestos Packing (Optional)
- F. Chrome Plated Rod & Molded Convex Packing (Optional)
- G. Chrome Plated Rod & Molded Rubber & Duck Packing (Optional)
- H. Stainless Steel Rod & Braided Asbestos Packing (Optional)
- J. Stainless Steel Rod & Molded Convex Packing (Optional)
- K. Stainless Steel Rod & Molded Rubber & Duck Packing (Optional)

COLUMN 10 - FLUID VALVE SELECTIVE

- A. Bronze - Wing Guided Type without Insert - for Water Service
- B. Bronze - Wing Guided Type with Rubber Insert - for Water Service
- C. Iron - Wing Guided Type without Insert - for Oil, Water or General Service
- D. Steel - Wing Guided Type without Insert - for Oil or General Service
- E. Steel - Wing Guided Type with Rubber Insert - for Slush or Grout & Cement Service
- F. Steel (Gravel Type) - Wing Guided with Insert - for Slush or Grout & Cement Service
- G. Steel - Center Guided Type without Insert - for Oil or General Service
- H. Steel - Center Guided Type with Rubber Insert - for Slush or Grout & Cement Service
- J. Steel - Center Guided Type with Polyurethane Insert - for Slush or Grout & Cement Service
- K. Steel - Seat & Delrin Ball (Optional)
- L. Stainless Steel - Seat & Delrin Ball (Optional)
- M. Stainless Steel - Durabla (Optional)
- N. Bronze - Ball Guided Spherical (Optional)
- P. Steel - Ball Guided Spherical (Optional)
- Q. Stainless Steel - Ball Guided Spherical (Optional)

COLUMN 11 - OPTIONAL EQUIPMENT SELECTIVE

INSTRUCTIONS FOR ORDERING REPAIR PARTS

When ordering parts, specify complete eleven (11) character Pump Model, Size and Serial Number (see name plate on pump). Serial Number is also stamped on cylinder end of frame.

All orders for Parts should be placed with the nearest Sales and Service Office.

Reference numbers shown in the left hand column of the Parts Lists are used to help locate the parts shown on the Drawings and Sectional Views.
DO NOT ORDER BY REFERENCE NUMBERS.

After locating the reference number, the part number may be found for your particular pump unit under the correct Model Number column.

Specify exactly the number of parts required (see column "Qty. Req. Per Pump").
DO NOT ORDER BY SETS.

To determine the Right Hand and Left Hand side of the pump, stand at the power end and face the fluid end of the pump.

PARTS RETURNED

All claims must be made within five days after receipt of goods. If order has been filled correctly, we cannot allow the return of the goods without our consent and then only a basis of a charge for service and rehandling plus transportation charges.

Transportation charges must be prepaid. If it is necessary to return a part to the factory for duplication or inspection, do not fail to do the following:

1. Write the nearest Sales and Service Office a letter advising what material you wish to return and why.
2. After receiving permission to return the item or items, obtain from the Sales and Service Office the correct forms filled out by that office for the proper return of material.
3. Place a tag in the package showing your name and address.
4. Tag each article in the box or package stating what and how many are returned.
5. Always give the serial number of the machine from which the parts were removed or the invoice number on which the parts were originally shipped.

All parts returned for credit should be handled in the same manner as that for duplication or inspection.

The current Model Identifications in this Parts List supersedes FYFXX, FDFXX and FCFXX.

<u>(FYFXX)</u> <u>CURRENT</u>	<u>(FDFXX)</u> <u>CURRENT</u>	<u>(FCFXX)</u> <u>CURRENT</u>
FXXA	FXXB	FXXD
FXXE	FXXC	FXXH
FXXJ	FXXF	FXXM
FXXN	FXXG	FXXQ
FXXR	FXXK	FXXU
	FXXL	
	FXXP	
	FXXS	
	FXXT	

N.D.S. Drilling Supply
26041 Newton Circle
Elko, MN 55020
Phone #952-461-3400
Fax # 952-461-3403

INDEX

Connecting Rod & Crosshead	5	Pistons, Cup Type	15
Cylinder, Fluid	6 Thru 11	Pistons, Follower	14
Cylinder Liners	13	Pistons, Steel Insert	14
Eccentric & Shaft	4	Pistons, Solid	15
Eccentric Shaft Bearings	5	Puller, Crosshead Pin Bushing	25
Frame	2	Puller Valve Seat	22 Thru 24
Jackshaft	3	Rod Oiler	26, 27
Liner Puller	25	Stuffing Box	12
Oil Stop Head	4	Stuffing Box Gland	12
Ordering Instructions	1	Surge Chamber	28
Piston Rod	13	Valves	16 Thru 22

Order by Part Number and Description. Reference Numbers for your Convenience Only.

N.D.S. Drilling Supply
 26041 Newton Circle
 Elk, MN 55020
 Phone #952-461-3400
 Fax # 952-461-3403

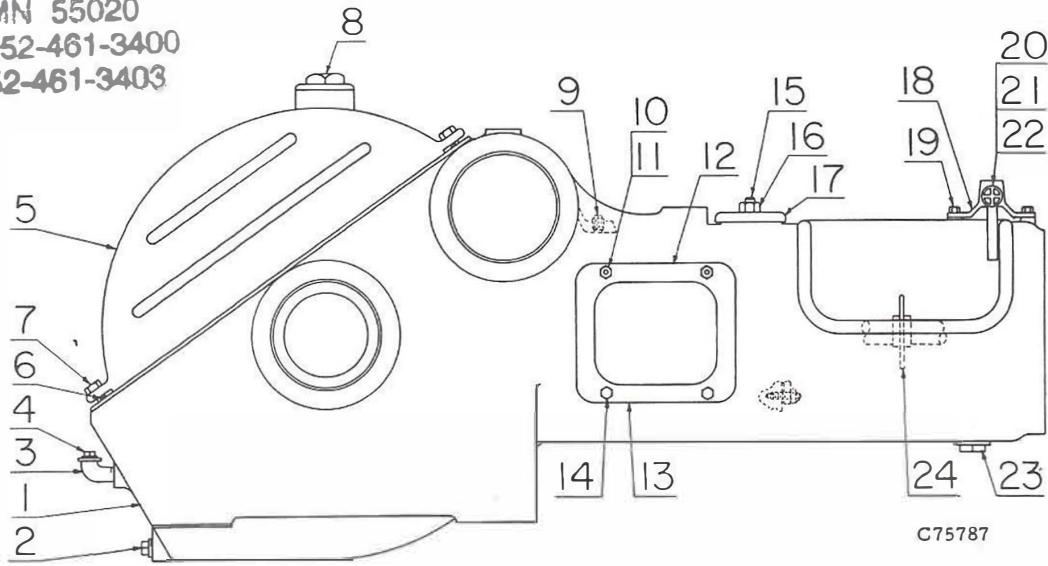

Ref. No.	Name of Part	Qty. Req. Per Pump	All FXX Models
FRAME			
			Part No.
1	ASM FRAME, Incl. Ref. No. 2, 3, 4, 9, 10, 11, 15, 16 & 23	1	200FXX001A
2	PLUG-SqHd PIPE, Oil Drain	1	64A5
3	ELBOW-PIPE STREET, Oil Level	1	64D4
4	PLUG-SqHd PIPE, Oil Level	1	64AA4
5	HOOD	1	FXX246
6	GASKET, Hood	96"	2009457
7	SCREW, Hood	12	75AA1
8	COVER-FILLER	1	FXX880
9	PLUG-SqHd PIPE, Crosshead	2	64AA7
10	STUD, Crosshead Inspection Plate	4	79A6
11	NUT, Crosshead Inspection Plate Stud	4	50B5
12	PLATE-INSPECTION, Crosshead	2	FXX723
13	GASKET, Crosshead Inspection Plate	2	25C1180
14	SCREW, Crosshead Inspection Plate	4	75A4
15	STUD, Plate Inspection	1	79A338
16	NUT, Plate Inspection Stud	1	50B3
17	PLATE-INSPECTION	1	1PXD237
18	MANIFOLD-WATER *	1	1FXX315
19	SCREW, Water Manifold *	2	75A5
20	VALVE-ANGLE *	2	90F4
21	NIPPLE-PIPE *	2	63D9
22	NIPPLE-PIPE *	2	63D14
23	PLUG-SqHd PIPE, Frame Sludge Drain	1	64A5
24	BAFFLE, Piston Rod	2	1FXX840

* Reference No. 18 thru 22 are optional equipment items (slush service piston rod washing).

Order by Part Number and Description. Reference Numbers for your Convenience Only.

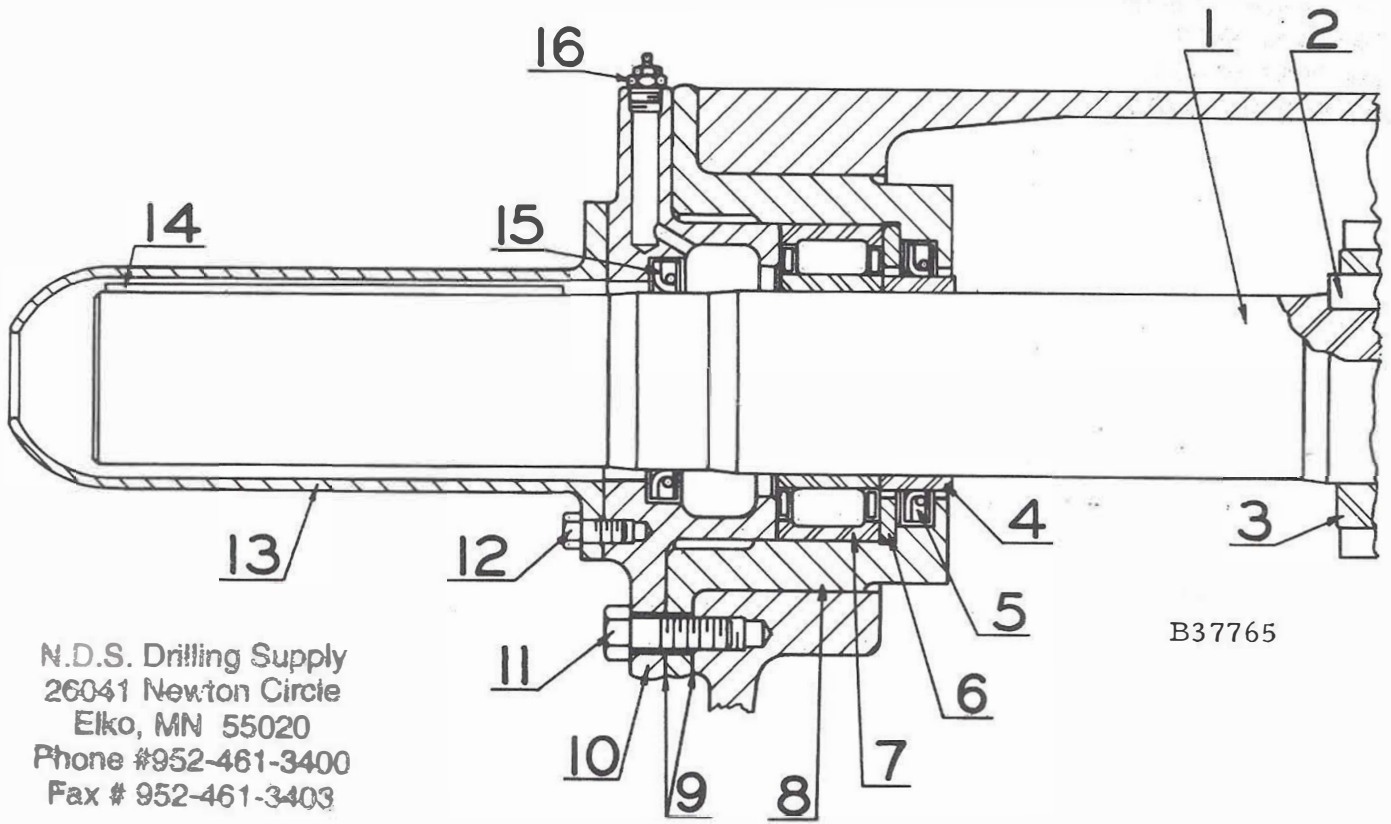

N.D.S. Drilling Supply
 26041 Newton Circle
 Elko, MN 55020
 Phone #952-461-3400
 Fax # 952-461-3403

Ref. No.	Name of Part	Qty. Req. Per Pump	A11 FXX Models
JACKSHAFT			
			Part No.
	ASM JACKSHAFT, Incl. Ref. #1, 2 & 3	1	FXX374
1	JACKSHAFT	1	FXX371
2	KEY, Jackshaft to Gear	1	35C56
3	GEAR-DRIVER	1	FXX181
4	SLEEVE-SHAFT	2	FXX289
5	SEAL-OIL, Bearing Housing	2	60G5
6	SPACER, Bearing	2	FXX376
7	BEARING, Jackshaft	2	12W4
8	HOUSING-BEARING	2	1FXX368
9	GASKET, Housing & Retaining Plate	4	25C973
10	PLATE-BEARING RETAINING	2	4FXX370
11	SCREW, Housing & Retaining Plate	12	75A17
12	SCREW, Shaft Extension Cover	4	75A5
13	COVER-SHAFT EXTENSION	1	200FXX490
14	KEY, Jackshaft	1	35B99
15	SEAL-OIL, Bearing Retaining Plate	2	60G19
16	FITTING-LUB	2	40E5

N.D.S. Drilling Supply
 26041 Newton Circle
 Elko, MN 55020
 Phone #952-461-3400
 Fax # 952-461-3403

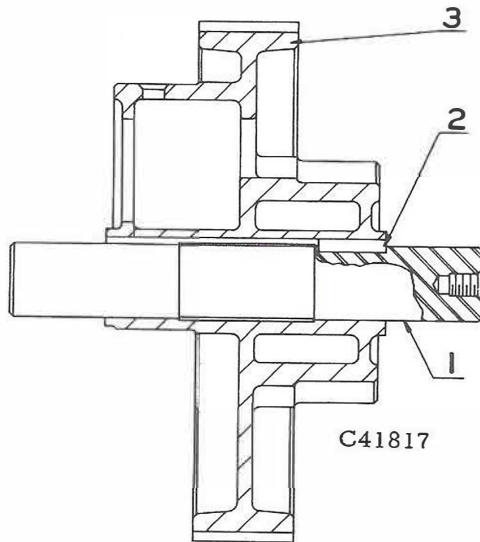

Ref. No.	Name of Part	Qty. Req. Per Pump	All FXX Models
ECCENTRIC & SHAFT			
			Part No.
1	SHAFT-ECCENTRIC	1	1FXX367
2	KEY, Eccentric Shaft	1	35C68
3	ECCENTRIC	1	1FXX255

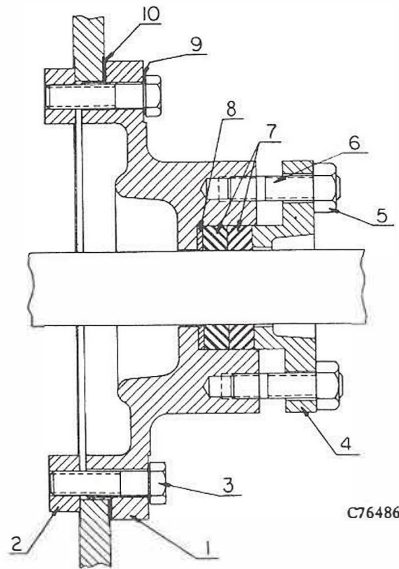

Ref. No.	Name of Part	Qty. Req. Per Pump	All FXX Models
OIL STOP HEAD			
			Part No.
1	ASM OIL STOP HEAD, Incl. Ref. No. 5 & 6	2	200FXX051A
2	PLATE-RETAINING	4	201FXX168
3	SCREW-HEX CAP	8	75A54
4	GLAND	2	PXD238
5	NUT-HEX	4	50B5
6	STUD	4	79A69
7	PACKING	2	60BG26
8	RING-JUNK	2	BC318
9	GASKET-RING	8	25F9
10	GASKET	2	25BC177

Order by Part Number and Description. Reference Numbers for your convenience only.

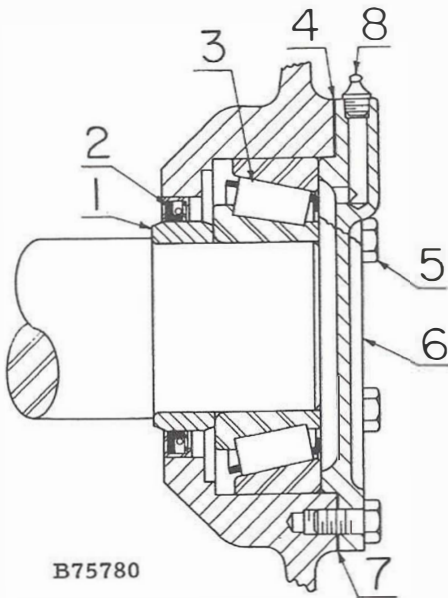

B75780

Ref. No.	Name of Part	Qty. Req. Per Pump	All FXX Models
ECCENTRIC SHAFT BEARING			Part No.
1	SLEEVE-SHAFT	2	20AUX18
2	SEAL-OIL	2	60G7
3	BEARING, Eccentric Shaft	2	12C33
4	SHIM, Bearing Cover Plate (Used Opposite 25C973 Gasket)	2	77B20
5	SCREW, Bearing Cover Plate	12	75A18
6	PLATE-BEARING COVER	2	FXX366
7	GASKET, Bearing Cover Plate (Used Opposite 77B20 Shim)	1	25C973
8	FITTING-LUB, Bearing Cover Plate	2	40E5

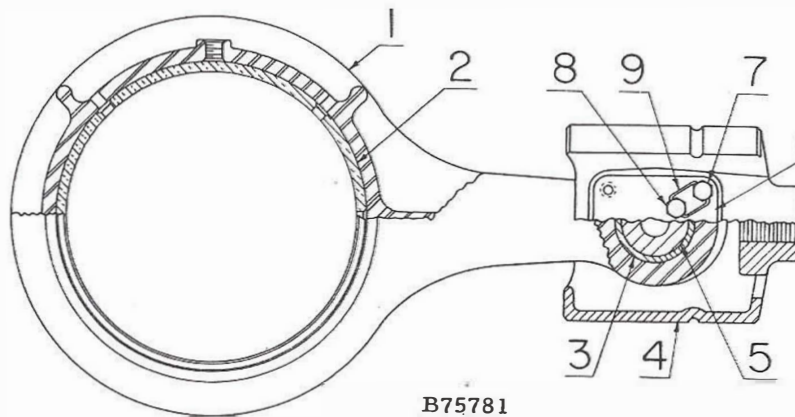

B75781

N.D.S. Drilling Supply
 26041 Newton Circle
 Elko, MN 55020
 Phone #952-461-3400
 Fax # 952-461-3403

Ref. No.	Name of Part	Qty. Req. Per Pump	All FXX Models
CONNECTING ROD & CROSSHEAD			Part No.
1	ASM CONNECTING ROD, Incl. Ref. #2 & 3	2	2FXX417
2	BUSHING (Eccentric End)	2	2FXX421
3	BUSHING (Crosshead End)	2	FXX229
4	CROSSHEAD	2	FXX175
5	PIN-CROSSHEAD	2	1FXX189
6	PLATE-RETAINER	2	1FXX281
7	SCREW (1-1/4" lg.), Retainer Plate	4	75B11
8	SCREW (1" lg.), Retainer Plate	4	75B13
9	WIRE	48"	97A29

N.D.S. Drilling Supply
26041 Newton Circle
Elko, MN 55020
Phone #952-461-3400
Fax # 952-461-3403

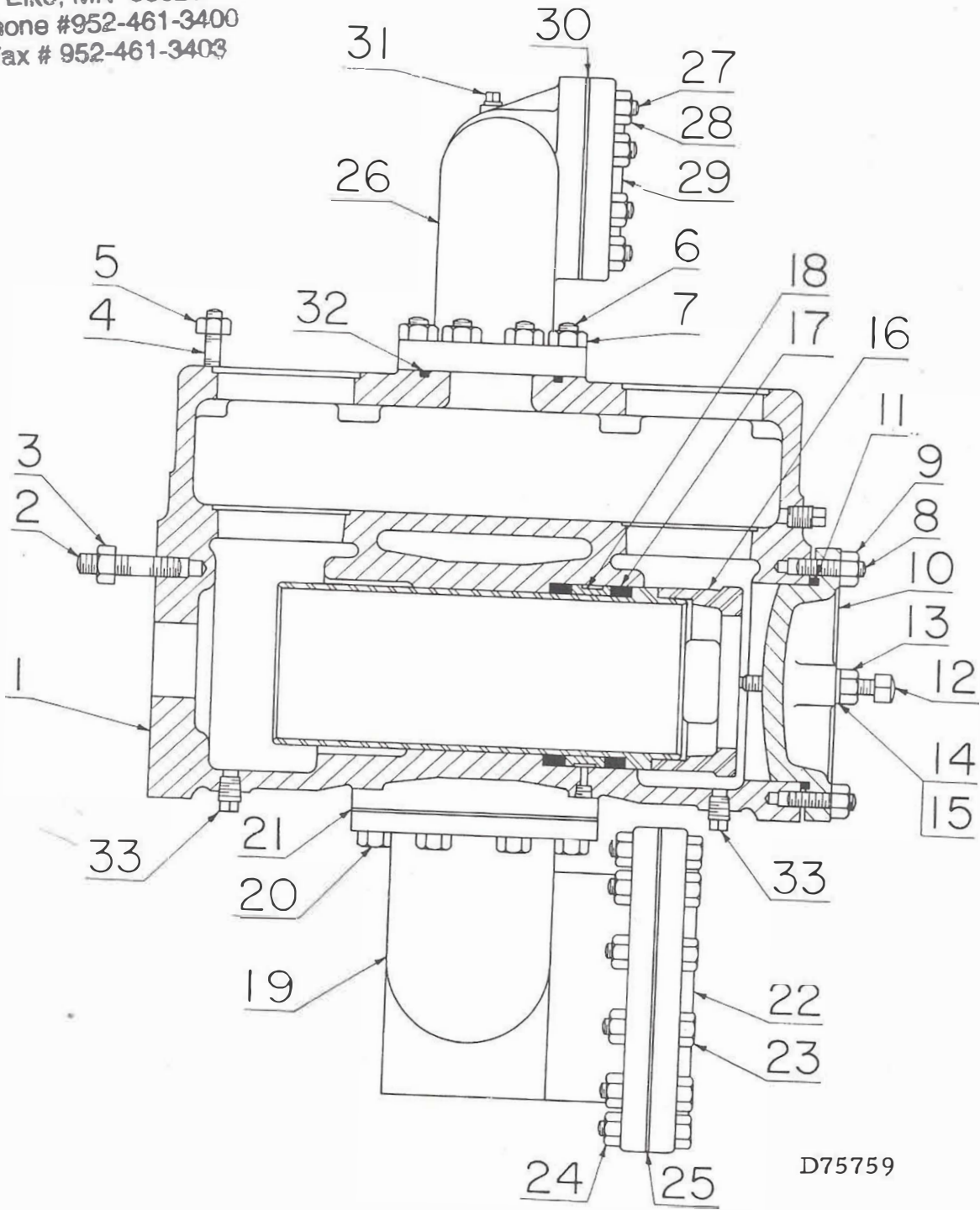

D75759

FOR LIST OF PARTS SEE PAGE 7

Order by Part Number and Description. Reference Numbers for your convenience only.

(FYFXX)

7-1/2 X 8

Models

FXXA_B

FXXE_B

FXXJ_B

FXXN_B

FXXR_B

Ref. No.	Name of Part	Qty. Req. Per Pump	Part No. (Iron)
FLUID CYLINDER			
1	ASM FLUID CYLINDER (RH)*, Incl. Ref. #2 thru 9 .	1	200FYY029B
1	ASM FLUID CYLINDER (LH)*, Incl. Ref. #2 thru 9 .	1	201FYY029B
2	STUD, Cylinder to Frame	12	79A557
3	NUT, Cylinder to Frame Stud	12	50B10
4	STUD, Valve Cover	32	79A92
5	NUT, Valve Cover Stud	32	50B9
6	STUD, Discharge Manifold	16	79L4
7	NUT, Discharge Manifold Stud	16	50B8
8	STUD, Cylinder Head	18	79A183
9	NUT, Cylinder Head Stud	18	50B8
10	HEAD-CYLINDER	2	FY41
11	GASKET, Cylinder Head	2	25G8
12	SET SCREW, Liner Clamp	6	1FY207
13	NUT, Liner Clamp Set Screw	6	50B9
14	PACKING, Liner Clamp Set Screw	6	60BQ3
15	WASHER, Liner Clamp Set Screw	6	95F9
16	CLAMP-LINER	2	F0217
17	SLEEVE, Liner	4	3EN519
18	SPACER, Liner Sleeve	2	EN957
19	MANIFOLD-SUCTION	1	200FYY069
20	SCREW, Suction Manifold to Cylinder	16	75A74
21	GASKET, Suction Manifold to Cylinder	2	25BC105
22	FLANGE, Suction Manifold	1	64EB131
23	SCREW, Suction Manifold Flange	12	75A150
24	NUT, Suction Manifold Flange Screw	12	50B9
25	GASKET, Suction Manifold Flange	1	25C1154
26	DISCHARGE MANIFOLD, Incl. Ref. #27 & 31	1	2F0280
27	STUD, Discharge Manifold Flange	8	79L4
28	NUT, Discharge Manifold Flange Stud	8	50B8
29	FLANGE, Discharge Manifold	1	64DA12
30	GASKET, Discharge Manifold Flange	1	25T34
31	PLUG-SqHd PIPE, Discharge Manifold	1	64AA5
32	GASKET, Discharge Manifold to Cylinder	1	25T34
33	PLUG, Cylinder Priming & Drain	6	64AU5

* For definition of Right Hand and Left Hand side of pump, see ordering instructions on Page 1.

N.D.S. Drilling Supply
 26041 Newton Circle
 Elko, MN 55020
 Phone #952-461-3400
 Fax # 952-461-3403

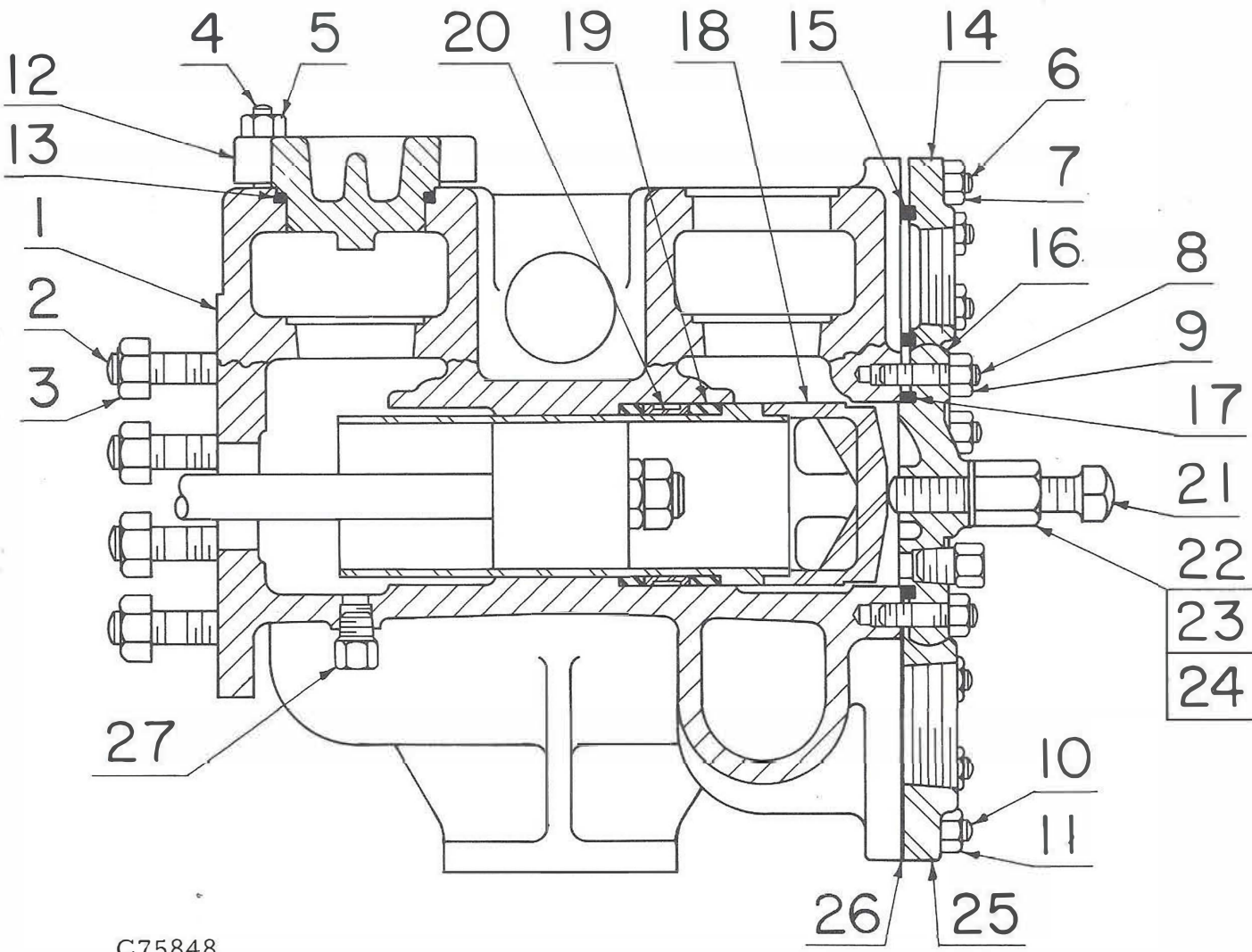

C75848

FOR LIST OF PARTS SEE PAGE 9

N.D.S. Drilling Supply
 26041 Newton Circle
 Elko, MN 55020
 Phone #952-461-3400
 Fax # 952-461-3403

Order by Part Number and Description. Reference Numbers for your convenience only.

(FDFXX)

5 X 8 / 5-1/2 X 8

Ref. No.	Name of Part	Qty. Req. Per Pump	Models	
			FXXC_B	FXXB_B
			FXXG_B	FXXF_B
			FXXL_B	FXXK_B
			FXXP_B	FXXS_B
			FXXT_B	
	FLUID CYLINDER		Part No. (Iron)	Part No. (Iron)
1	ASM FLUID CYLINDER, Incl. Ref. #2 thru 11 .	1	1FD388	6FD29B
2	STUD, Cylinder to Frame	12	79L92	79L92
3	NUT, Cylinder to Frame Stud	12	50B10	50B10
4	STUD, Valve Cover	16	79A559	79A559
5	NUT, Valve Cover Stud	16	50B13	50B13
6	STUD, Discharge Flange	8	79A183	79A183
7	NUT, Discharge Flange Stud	8	50B8	50B8
8	STUD, Cylinder Head	24	79A183	79A183
9	NUT, Cylinder Head Stud	24	50B8	50B8
10	STUD, Suction Flange	8	79A183	79A183
11	NUT, Suction Flange Stud	8	50B8	50B8
12	COVER-VALVE (See Valve Pages)			
13	GASKET, Valve Cover (See Valve Pages)			
14	FLANGE, Discharge	1	64DA5	64DA5
15	GASKET, Discharge Flange	1	25G4	25G4
16	HEAD-CYLINDER	2	5FD41	4FD41
17	GASKET, Cylinder Head	2	25G12	25G43
18	CLAMP-LINER	2	FD217	3FD217
19	SLEEVE-LINER	4	4EF519	25T32
20	SPACER-LINER	2	FC957	FD445
21	SET SCREW, Liner	2	76W3	76W3
22	NUT, Liner Set Screw	2	50B12	50B12
23	WASHER, Liner Set Screw	2	95F12	95F12
24	PACKING, Liner Set Screw	2	60BQ6	60BQ6
25	FLANGE, Suction	1	FD77	FD77
26	GASKET, Suction Flange	1	25C320	25C320
27	PLUG, Cylinder Cleanout	5	64AU5	64AU5

N.D.S. Drilling Supply
 26041 Newton Circle
 Elko, MN 55020
 Phone #952-461-3400
 Fax # 952-461-3403

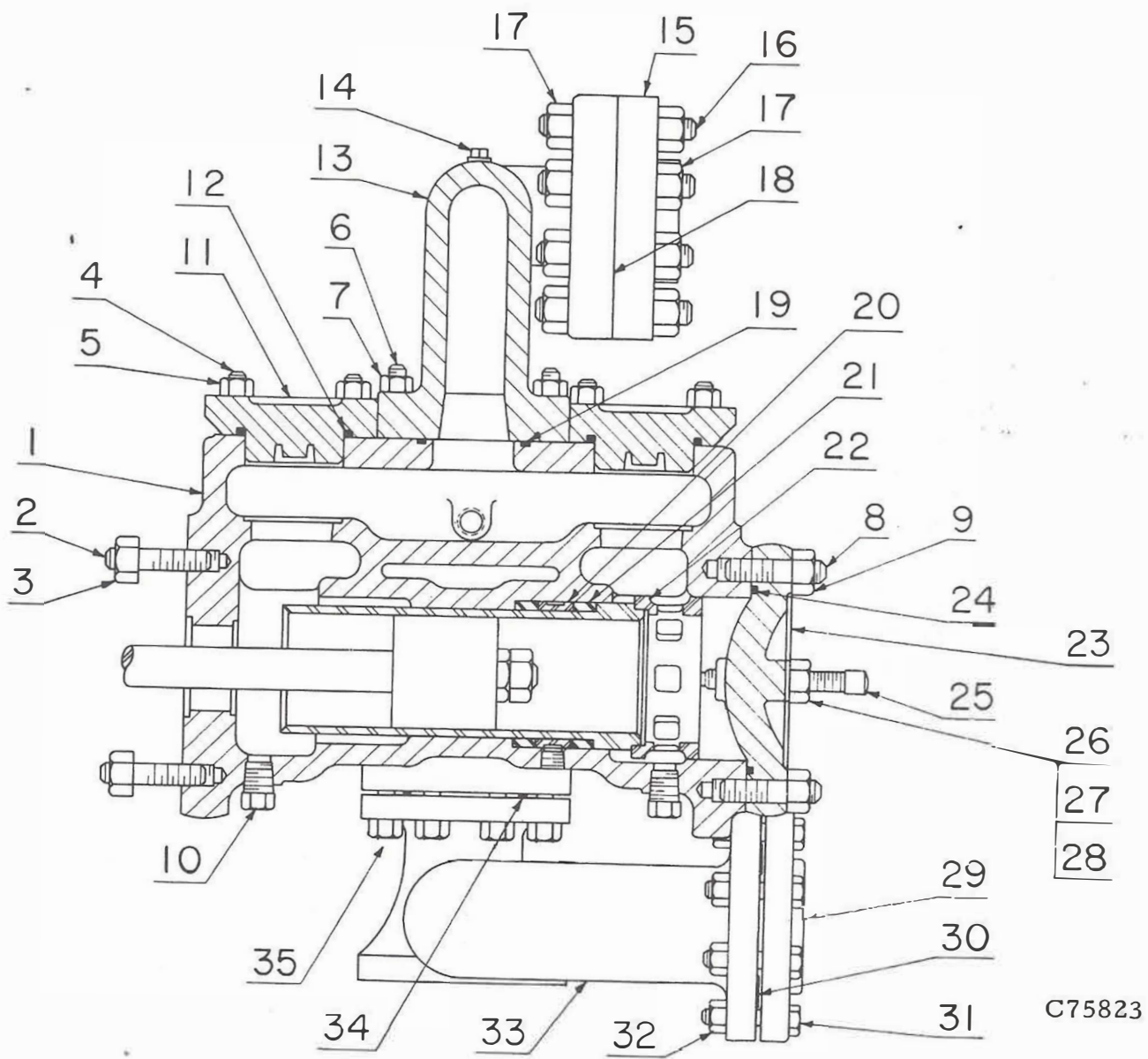

C75823

FOR LIST OF PARTS SEE PAGE 11

N.D.S. Drilling Supply
 26041 Newton Circle
 Elko, MN 55020
 Phone #952-461-3400
 Fax # 952-461-3403

Order by Part Number and Description. Reference Numbers for your convenience only.

(FCFXX)

Ref. No.	Name of Part	Qty. Req. Per Pump	Models	
			FXXD_B FXXM_B FXXQ_B FXXU_B	Model FXXH_B
			Part No. (Steel)	Part No. (Steel)
FLUID CYLINDER				
1	ASM FLUID CYLINDER (LH),* Incl. Ref. #2 thru 9	1	21FC29LF	23FC29LF .
1	ASM FLUID CYLINDER (RH),* Incl. Ref. #2 thru 9	1	21FC29RF	23FC29RF
2	STUD, Cylinder to Frame	12	79L114	79L114
3	NUT, Cylinder to Frame Stud	12	50B10	50B10
4	STUD, Valve Cover	64	79L4	79L4
5	NUT, Valve Cover Stud	64	50B8	50B8
6	STUD, Discharge Manifold	16	79L65	79L65
7	NUT, Discharge Manifold Stud	16	50B8	50B8
8	STUD, Cylinder Head	24	79L80	79L80
9	NUT, Cylinder Head Stud	24	50B10	50B10
10	PLUG, Priming & Drain	6	64AU5	64AU5
11	COVER-VALVE (See Valve Pages)			
12	GASKET, Valve Cover (See Valve Pages)			
13	ASM DISCHARGE MANIFOLD, Incl. Ref. #14 thru 18	1	200FCC071A	200FCC071A
14	PLUG, Discharge Manifold	1	64AA5	64AA5
15	FLANGE, Discharge	1	202FCC073	202FCC073
16	STUD, Discharge Flange	8	79L9	79L9
17	NUT, Discharge Flange	8	50B36	50B36
18	GASKET, Discharge Flange	1	25T15	25T15
19	GASKET, Manifold to Cylinder	2	25T20	25T20
Ø	PLUG, SqHd PIPE	2	64AA9	64AA9
20	SPACER-LINER	2	FC957	FC957
21	SLEEVE-LINER	4	4EF519	4EF519
22	CLAMP-LINER	2	FC217	FC217
23	HEAD-CYLINDER	2	3FC41	3FC41
24	GASKET, Cylinder Head	2	25T40	25T40
25	SET SCREW, Liner	6	1FY207	1FY207
26	NUT, Liner Set Screw	6	50B9	50B9
27	WASHER, Liner Set Screw	6	95F9	95F9
28	PACKING, Liner Set Screw	6	60BQ3	60BQ3
	ASM SUCTION MANIFOLD, Incl. Ref. #29 thru 34	1	2EF499	2EF499
29	FLANGE, Suction	1	64DE8	64DE8
30	GASKET, Suction Flange	1	25C320	25C320
31	SCREW, Suction Flange	8	75A214	75A214
32	NUT, Suction Flange Screw	8	50B8	50B8
33	MANIFOLD-SUCTION	1	2EF110	2EF110
34	GASKET, Suction Manifold to Cylinder	2	25G18	25G18
35	SCREW, Suction Manifold	16	75A74	75A74

* For definition of Right Hand and Left Hand side of pump, see ordering instructions on Page 1.
Ø Not shown on illustration.

Order by Part Number and Description. Reference Numbers for your convenience only.

N.D.S. Drilling Supply
 26041 Newton Circle
 Elko, MN 55020
 Phone #952-461-3400
 Fax # 952-461-3403

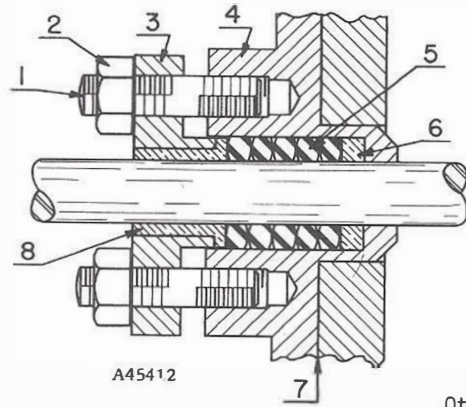

Ref. No.	Name of Part	Qty. Req. Per Pump	(FYFX) (FDXX) Models		
			FXXA_B	FXXG_B	FXXP_B
			FXXB_B	FXXJ_B	FXXR_B
			FXXC_B	FXXK_B	FXXS_B
			FXXE_B	FXXL_B	FXXT_B
			FXXF_B	FXXN_B	

STUFFING BOX
FOR IRON FLUID ENDS

Ref. No.	Name of Part	Qty. Req. Per Pump	Part No.
1	STUD, Stuffing Box	4	79A183
2	NUT, Stuffing Box Stud	4	50B8
3	GLAND, Stuffing Box	2	FD21
4	ASM STUFFING BOX, Incl. Ref. #1 & 2	2	2007956
5	PACKING, Braided Asbestos (Oil & Water Serv)*	2	60BG13
5	PACKING, Oil Resistant Molded Convex (Standard Slush Service)*	2	60BH2
5	PACKING, Molded Rubber & Duck (Optional Slush Service)*	2	60DA415
6	RING-JUNK, Stuffing Box	2	BC317
7	GASKET, Stuffing Box	2	25C1737
8	BUSHING-GLAND	2	1FD152

(FCFX).

Ref. No.	Name of Part	Qty. Req. Per Pump	Models	
			FXXD_B	FXXQ_B
			FXXH_B	FXXU_B
			FXXM_B	

STUFFING BOX
FOR STEEL FLUID ENDS

Ref. No.	Name of Part	Qty. Req. Per Pump	Part No.
1	STUD, Stuffing Box Gland	4	79L11
2	NUT, Stuffing Box Gland Stud	4	50B9
3	GLAND, Stuffing Box	2	1FC21
4	ASM STUFFING BOX, Incl. Ref. #1 & 2	2	16FC14B
5	PACKING, Braided Asbestos (Oil & Water Serv)*	2	60BG13
5	PACKING, Oil Resistant Molded Convex (Standard Slush Service)*	2	60BH2
5	PACKING, Molded Rubber & Duck (Optional Slush Service)*	2	60DA415
6	RING-JUNK	2	BC317
7	GASKET, Stuffing Box	2	25AL35
8	BUSHING-GLAND	2	1FD152

* Selective for Column 9

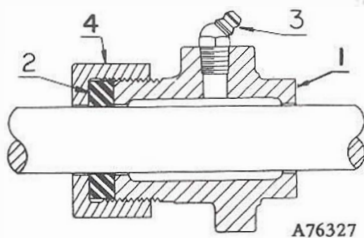

Ref. No.	Name of Part	Qty. Req. Per Pump	All FXX Models
	STUFFING BOX GLAND (OPTIONAL EQPT.)		Part No.
	ASM GLAND, Incl. Following 4 Items	2	200FXX008A
1	GLAND	2	200FXX008
2	PACKING-RING	2	60DD75
3	FITTING-LUBE	2	40E10
4	NUT	2	200FXX086

Order by Part Number and Description. Reference Numbers for your convenience only.

CYLINDER LINERS *
TWO (2) REQUIRED PER PUMP

Size	(FYFXX) Models		Size	(FCFXX) Models	
	FXXA_B	FXXN_B		FXXD_B	FXXQ_B
	FXXE_B	FXXR_B		FXXH_B	FXXU_B
	Hardened Steel	Bronze		Hardened Steel	Bronze
	Part No.	Part No.		Part No.	Part No.
7-1/2"	FY45675	FY6275BB	5"	1EF45650	33EF64
7-1/4"	FZ45672	FZ6272BB	4-1/2"	1EF45645	34EF64
7"	FZ45670	FZ6270BB	4"	1EF45640	35EF64
6-3/4"	FZ45667	FZ6267BB	3-1/2"	1EF45635	36EF64
6-1/2"	FZ45665	FZ6265BB	3"	1EF45630	37EF64
6"	FZ45660	FZ6260BB	2-1/2"	1EF45625	38EF64
5-1/2"	FZ45655	FZ6255BB			
5"	FZ45650	FZ6250BB			

Size	(FDFXX) Models			(FDFXX) Models	
	FXXC_B	FXXP_B	Bronze	FXXB_B	FXXK_B
	FXXG_B	FXXT_B		FXXF_B	FXXS_B
	Stainless Steel	Hardened Steel		Hardened Steel	
	Part No.	Part No.	Part No.	Part No.	
5-1/2"	None	None	None	FD45655	
5"	16FD64	FD45650	FD64	1FD45650	
4-1/2"	20FD64	FD45645	3FD64	2FD45645	
4"	22FD64	FD45640	6FD64	1FD45640	
3-1/2"	24FD64	FD45635	9FD64	200FDD456	
3"	26FD64	FD45630	12FD64	None	
2-1/2"	28FD64	FD45625	15FD64	None	

* Selective for Column 7

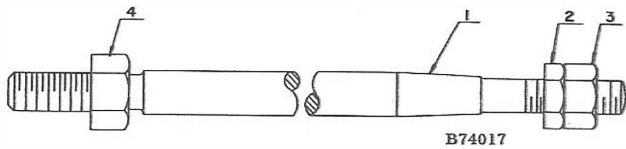

PISTON ROD & NUTS **
(API NO. 3 TAPER)

Ref. No.	Qty. Req. Per Pump	(FDFXX) (FCFXX) Models	
		(FYFXX) Models	(FDFXX) (FCFXX) Models
		FXXB_B	FXXL_B
		FXXC_B	FXXM_B
		FXXA_B	FXXP_B
		FXXE_B	FXXQ_B
		FXXJ_B	FXXS_B
		FXXN_B	FXXT_B
		FXXR_B	FXXU_B
		Part No.	Part No.
1	HARDENED STEEL PISTON ROD, Incl. Ref. #2 & 3	FXX183	5EF183
2	NUT (Thin)	None	None
3	NUT (Full)	50V7	50V7
4	NUT, Crosshead	50T137	50T137
1	BRONZE PISTON ROD, Incl. Ref. #2 & 3	2FXX183	11EF183
2	NUT (Thin)	50T235	50Y12
3	NUT (Full)	50T236	50X19
4	NUT, Crosshead	50T137	50T137
1	STAINLESS STEEL PISTON ROD, Incl. Ref. #2 & 3	4FXX183	13EF183
2	NUT (Thin)	50T156	None
3	NUT (Full)	50T157	50V7
4	NUT, Crosshead	50T137	50T137
1	CHROME PLATED PISTON ROD, Incl. Ref. #2 & 3	5FXX183	14EF183
2	NUT (Thin)	None	None
3	NUT (Full)	50V7	50V7
4	NUT, Crosshead	50T137	50T137

** Selective for Column 9

Order by Part Number and Description. Reference Numbers for your convenience only.

N.D.S. Drilling Supply
 26041 Newton Circle
 Elko, MN 55020
 Phone #952-461-3400
 Fax # 952-461-3403

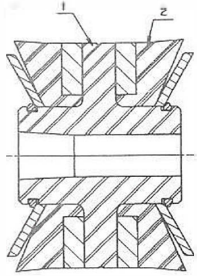

STEEL INSERT-TYPE PISTON *
 STANDARD FOR
 SLUSH, GROUT & CEMENT SERVICE
 (API NO. 3 TAPER)

C76948

(FYFXX)
 Models FXXA_B & FXXE_B

(FYFXX) (FDFXX)
 Models

FXXA_B FXXB_B
 FXXE_B FXXF_B

Ref. No.	Name of Part	Qty. Req. Per Pump	7-1/2"		7-1/4"		7"		6-3/4"		6-1/2"		6"		5-1/2"	
			Part No.	Part No.	Part No.	Part No.	Part No.	Part No.	Part No.	Part No.	Part No.	Part No.	Part No.	Part No.		
1	ASM PISTON, Inc. Ref. #2	2	212TBB045A	211TBB045A	210TBB045A	209TBB045A	208TBB045A	206TBB045A								
2	INSERT GROUP, Incl. Retainer Plates & Rings	2	TBB76021	TBB76020	TBB76019	TBB76018	TBB76017	TBB76015	TBB76013							

(FYFXX)
 (FDFXX)
 (FCFXX)
 Models

FXXA_B FXXE_B
 FXXB_B FXXC_B
 FXXF_B FXXG_B
 FXXD_B FXXH_B

(FDFXX) (FCFXX)
 Models

FXXB_B FXXD_B
 FXXC_B FXXH_B
 FXXF_B
 FXXG_B

(FDFXX) (FCFXX)
 Models

FXXC_B FXXD_B
 FXXG_B FXXH_B

Ref. No.	Name of Part	Qty. Req. Per Pump	5"		4-1/2"		4"		3-1/2"		3"	
			Part No.	Part No.	Part No.	Part No.	Part No.	Part No.	Part No.	Part No.		
1	ASM PISTON, Inc. Ref. #2	2	202TBB045A		200TBB045A		221TBK045A		220TBK045A		221TBA045A	
2	INSERT GROUP, Incl. Retainer Plates & Rings	2	TBB76011		TBB76009		TBK90423		TBK90422		TBA75994	

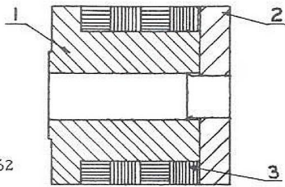

A44562

FOLLOWER TYPE FLUID PISTONS *
 STANDARD FOR WATER AND GENERAL SERVICE
 (API NO. 3 TAPER)

(FYFXX)
 Models FXXN_B & FXXR_B

(FYFXX) (FDFXX)
 Models

FXXN_B FXXS_B
 FXXR_B

Ref. No.	Name of Part	Qty. Req. Per Pump	7-1/2"		7-1/4"		7"		6-3/4"		6-1/2"		6"		5-1/2"	
			Part No.	Part No.	Part No.	Part No.	Part No.	Part No.	Part No.	Part No.	Part No.	Part No.	Part No.	Part No.		
1	BODY-PISTON (Iron)	2	FY45	17F045	19F045	21F045	23F045	27F045	31F045							
2	FOLLOWER-PISTON (Iron)	2	FY46	F046	18F046	3F046	2F046	4F046	6F046							
1	BODY-PISTON (Bronze)	2	1FY45	18F045	20F045	22F045	24F045	28F045	32F045							
2	FOLLOWER-PISTON (Bronze)	2	1FY46	1F046	19F046	8F046	9F046	10F046	12F046							
3	PACKING, Regular Cure	See ()	60D47(12)	2009041(12)	60D52(12)	2009042(16)	60D9(12)	60D8(12)	60D7(12)							
3	PACKING, Rock Hard	See ()	60Y47(12)	60Y2(12)	60Y52(12)	60Y3(16)	60Y9(12)	60Y8(12)	60Y7(12)							

(FYFXX)
 (FDFXX)
 (FCFXX)
 Models

FXXN_B FXXR_B
 FXXP_B FXXS_B
 FXXT_B FXXU_B
 FXXQ_B

(FDFXX) (FCFXX)
 Models

FXXP_B FXXQ_B
 FXXS_B FXXU_B
 FXXT_B

(FDFXX) (FCFXX)
 Models

FXXP_B FXXQ_B
 FXXT_B FXXU_B

Ref. No.	Name of Part	Qty. Req. Per Pump	5"		4-1/2"		4"		3-1/2"		3"		2-1/2"	
			Part No.	Part No.	Part No.	Part No.	Part No.	Part No.	Part No.	Part No.	Part No.	Part No.		
1	BODY-PISTON (Iron)	2	35F045		37F045		FD45		1FD45		2FD45		3FD45	
2	FOLLOWER-PISTON (Iron)	2	7F046		16F046		FD46		1FD46		2FD46		3FD46	
1	BODY-PISTON (Bronze)	2	36F045		38F045		4FD45		5FD45		6FD45		7FD45	
2	FOLLOWER-PISTON (Bronze)	2	13F046		22F046		4FD46		5FD46		6FD46		7FD46	
3	PACKING, Regular Cure	See ()	60D6(12)		60D22(12)		60D17(14)		60D25(14)		60D11(12)		60D13(10)	
3	PACKING, Rock Hard	See ()	60Y6(12)		60Y22(12)		60Y17(14)		60Y25(14)		60Y11(12)		60Y13(10)	

* Selective for Column 8

Order by Part Number and Description. Reference Numbers for your convenience only.

N.D.S. Drilling Supply
26041 Newton Circle
Elko, MN 55020
Phone #952-461-3400
Fax # 952-461-3403

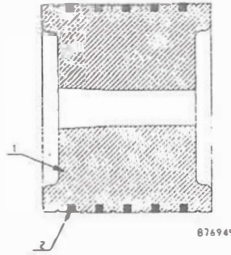

IRON SOLID-TYPE PISTON W/CAST IRON RINGS *
STANDARD FOR OIL SERVICE
(API NO. 3 TAPER)

(FYFXX)
Model FXXJ_B

(FYFXX) (FDFXX)
Models
FXXJ_B FXXK_B

Ref. No.	Name of Part	Qty. Req. Per Pump	7-1/2"	7-1/4"	7"	6-3/4"	6-1/2"	6"	5-1/2"
			Part No.	Part No.	Part No.	Part No.	Part No.	Part No.	Part No.
1	PISTON	2	FY350	1FY350	2FY350	3FY350	4FY350	6FY350	8FY350
2	RING-PISTON	See ()	65A43(10)	65A92(10)	65A39(10)	65A101(10)	65A17(10)	65A8(10)	65A6(10)

Models
(FYFXX) FXXJ_B
(FDFXX) FXXK & FXXL_B
(FCFXX) FXXM_B

(FDFXX) Models
FXXK & FXXL_B FXXM_B

(FDFXX) (FCFXX)
Models
FXXL_B FXXM_B

Ref. No.	Name of Part	Qty. Req. Per Pump	5"	4-1/2"	4"	3-1/2"	3"	2-1/2"
			Part No.	Part No.	Part No.	Part No.	Part No.	Part No.
1	PISTON	2	9FY350	FX0350	FD350	1FD350	2FD350	3FD350
2	RING-PISTON	See ()	65A3(10)	65A47(8)	65A33(8)	65A9(8)	65A14(8)	65A44(8)

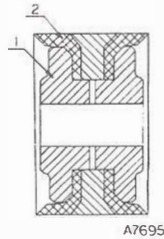

CUP-TYPE PISTONS *
IRON & STEEL FOR OIL & GENERAL SERVICE
BRONZE FOR WATER SERVICE
API NO. 3 TAPER (OPTIONAL)

(FYFXX)
Models FXXJ_B, FXXR_B & FXXN_B

(FYFXX) (FDFXX)
Models
FXXJ_B FXXK_B
FXXR_B FXXS_B
FXXN_B

Ref. No.	Name of Part	Qty. Req. Per Pump	7-1/2"	7-1/4"	7"	6-3/4"	6-1/2"	6"	5-1/2"
			Part No.	Part No.	Part No.	Part No.	Part No.	Part No.	Part No.
1	PISTON(IRON)Incl.Ref.#2 .	2	P3APIL750	P3APIL725	P3APIL700	P3APIL675	P3APIL650	P3APIL600	P3APIL550
1	PISTON(STEEL)Incl.Ref.#2.	2	P3APIL750S	P3APIL725S	P3APIL700S	P3APIL675S	P3APIL650S	P3APIL600S	P3APIL550S
1	PISTON(BRONZE)Incl.Ref.#2	2	P3APIL750B	P3APIL725B	P3APIL700B	P3APIL675B	P3APIL650B	P3APIL600B	P3APIL550B
2	CUP	4	60BB25	60BB24	60BB23	60BB22	60BB21	60BB19	60BB17

(FYFXX)
(FDFXX)
(FCFXX)
Models
FXXJ, FXXR & FXXN_B
FXXK, FXXL, FXXS,
FXXT & FXXP_B
FXXM, FXXU & FXXQ_B

(FDFXX) (FCFXX)
Models
FXXK, FXXL, FXXM_B
FXXS, FXXT & FXXU_B
FXXP_B FXXQ_B

(FDFXX) (FCFXX)
Models
FXXL_B FXXM_B
FXXT_B FXXU_B
FXXP_B FXXQ_B

Ref. No.	Name of Part	Qty. Req. Per Pump	5"	4-1/2"	4"	3-1/2"	3"
			Part No.	Part No.	Part No.	Part No.	Part No.
1	PISTON(IRON)Incl.Ref.#2 .	2	P3APIL500	P3APIL450	P3APIL400	P3APIL350	P3APIL300
1	PISTON(STEEL)Incl.Ref.#2.	2	P3APIL500S	P3APIL450S	P3APIL400S	P3APIL350S	P3APIL300S
1	PISTON(BRONZE)Incl.Ref.#2	2	P3APIL500B	P3APIL450B	P3APIL400B	P3APIL350B	P3APIL300B
2	CUP	4	60BB15	60BB13	60BB11	60BB9	60BB7

* Selective for Column 8

Order by Part Number and Description. Reference Numbers for your convenience only.

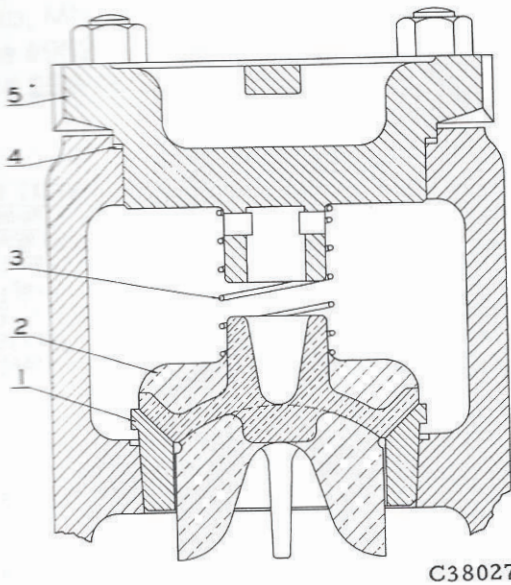

Ref. No.	Name of Part	Qty. Req. Per Pump	(FYFXX) Model FXXN_B
BRONZE WING GUIDED VALVE * WITHOUT INSERT WATER SERVICE (STD)			
			Part No.
1	SEAT-VALVE	8	7EN39
2	VALVE-FLUID	8	2EN206
3	SPRING (Brass)	8	78D83
4	GASKET, Valve Cover	8	25G32
5	COVER-VALVE	8	1FY147

For above valve, use one (1) 201FYY219A ASM Valve Seat Puller as shown on Page 22.

Ref. No.	Name of Part	Qty. Req. Per Pump	(FYFXX) Models FXXA_B FXXE_B
HARDENED STEEL WING GUIDED GRAVEL VALVE * WITH RUBBER INSERT SLUSH, GROUT & CEMENT SERVICE			
			Part No.
	ASM VALVE less Seat, Incl.		
	Ref. #1 thru 6	8	200FYY482A
1	VALVE-FLUID	8	200FYY482
2	INSERT, Rubber	8	200FYY106
3	WASHER-VALVE	8	200FYY279
4	BOLT-VALVE	8	200FYY012
5	LOCKNUT	8	50V6
6	BUSHING	8	2013547
7	SEAT-VALVE	8	200FYY039
8	SPRING	8	78A169
Ø	GASKET, Valve Cover	8	25G32
Ø	COVER-VALVE	8	1FY147

For above valve, use one (1) 202FYY219A ASM Valve Seat Puller as shown on Page 22.

Ø Not shown on illustration.
* Selective for Column 10.

7-1/2 X 8

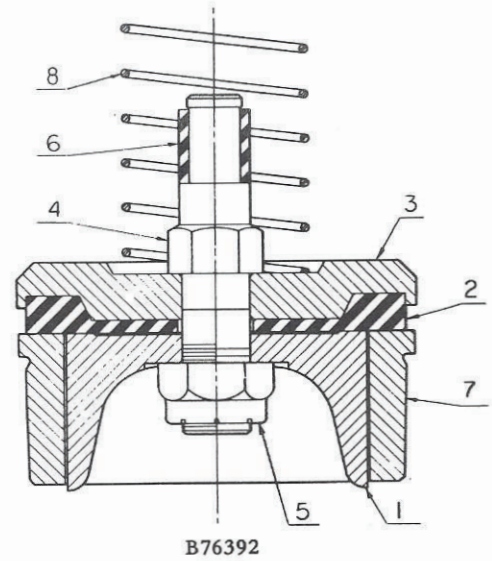

N.D.S. Drilling Supply
26041 Newton Circle
Elko, MN 55020
Phone #952-461-3400
Fax # 952-461-3403

Order by Part Number and Description. Reference Numbers for your convenience only.

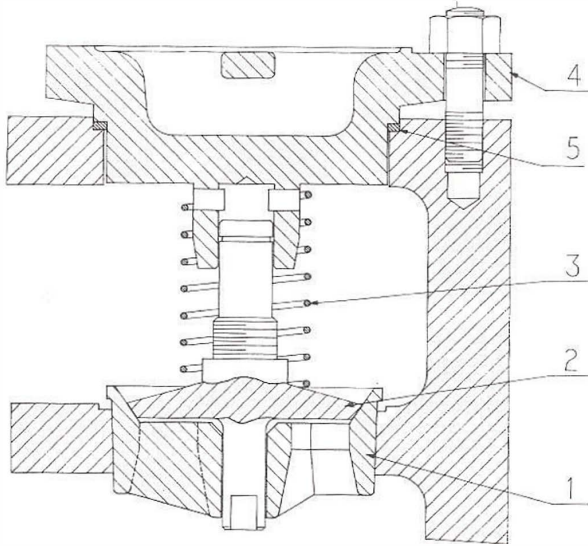

C77002

Ref. No.	Name of Part	Qty. Req. Per Pump	(FYFXX) Models FXXJ_B FXXR_B
STEEL FITTED-CENTER GUIDED VALVE * WITHOUT INSERT OIL & GENERAL SERVICE (STD)			
			Part No.
1	SEAT-VALVE	8	201FYY039
2	VALVE-FLUID.	8	202PZL482
3	SPRING	8	78A169
4	COVER-VALVE.	8	FY147
5	GASKET	8	25U32

Ref. No.	Name of Part	Qty. Req. Per Pump	(FYFXX) Models FXXA_B FXXE_B
----------	--------------	--------------------	------------------------------------

**STEEL FITTED-CENTER GUIDED VALVE *
WITH CARBOXYLATED RUBBER INSERT
SLUSH, GROUT & CEMENT SERVICE**

Ref. No.	Name of Part	Qty. Req. Per Pump	Part No.
	ASM VALVE, Incl. Ref. #1 Thru 4	8	202PZL482B
1	VALVE-FLUID	8	202PZL482
2	INSERT.	8	202PZL106
3	WASHER.	8	201PZL279
4	NUT	8	50V27
5	SEAT-VALVE.	8	201FYY039
6	SPRING.	8	78A139
7	GASKET.	8	25G32
8	COVER-VALVE	8	FY147

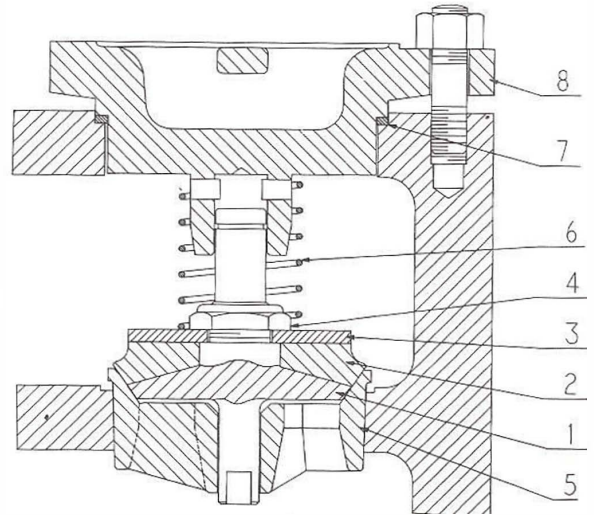

C77001

For above valves, use one (1) 100E9 ASM Valve Seat Puller as shown on Page 24.

* Selective for Column 10

Order by Part Number and Description. Reference Numbers for your convenience only.

M.D.S. Drilling Supply
 26041 Newton Circle
 Elko, MN 55020
 Phone #952-461-3400
 Fax # 952-461-3403

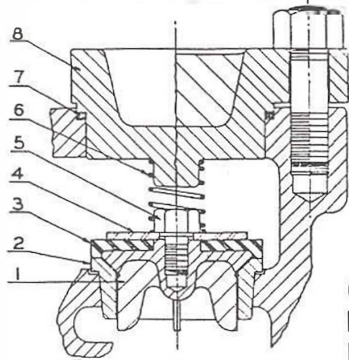

Ref. No.	Name of Part	Qty. Req. Per Pump	(FCFXX) Model FXXQ_B	(DFDXX) Models FXXB_B FXXC_B FXXF_B FXXG_B	(FCFXX) Models FXXD_B FXXH_B
----------	--------------	--------------------	----------------------	--	------------------------------

**WING GUIDED VALVE **
 WITH RUBBER INSERT
 WATER, SLUSH, GROUT & CEMENT SERVICE**

			Part No. (Bronze)	Part No. (Hardened Steel)	Part No. (Hardened Steel)
1	SEAT VALVE	8	6PA39	11FG39	4PA39
	ASM FLUID VALVE, Incl.Ref. #2 Thru 5	8	9EF206A	1FG928	11EF206A
2	VALVE-FLUID.	8	9EF206	17FG206	11EF206
3	INSERT	8	5EF452	1FG452*	5EF452
4	WASHER	8	95G35	95D49	95D53
5	SCREW.	8	7FF156	5FF156	5FF156
6	SPRING	8	78D88	78A171	78A298
7	GASKET, Valve Cover.	8	25AL36	25G18	25AL36
8	COVER-VALVE.	8	9FC147	FD147	9FC147

For Models FXDB, C, F & G use one (1) 1AUX545 ASM Valve Seat Puller as shown on Page 23.
 For Models FXDD, H & Q use one (1) 2015080 ASM Valve Seat Puller as shown on Page 23.

* Also available as 7FG452 Polyurethane Insert.

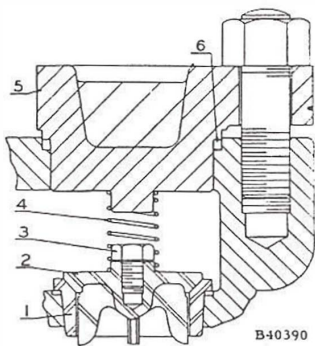

Ref. No.	Name of Part	Qty. Req. Per Pump	(FCFXX) Model FXXQ_B	(DFDXX) Models FXXK_B FXXL_B FXXS_B FXXT_B	(FCFXX) Models FXXM_B FXXU_B
----------	--------------	--------------------	----------------------	--	------------------------------

**WING GUIDED VALVE **
 WITHOUT INSERT
 OIL OR WATER SERVICE**

			Part No. (Bronze)	Part No. (Hardened Steel)	Part No. (Hardened Steel)
1	SEAT VALVE	8	6PA39	11FG39	4PA39
2	ASM FLUID VALVE, Incl.Ref. #3 & 4	8	9EF206B	17FG206C	11EF206B
3	SCREW.	8	7FF156	5FF156	5FF156
4	SPRING	8	78A299	78A134	78A299
5	COVER-VALVE.	8	9FC147	FD147	9FC147
6	GASKET	8	25AL36	25AV18	25AL36
Ø	WASHER	8	95G38	95D136	95D136

For Models FXDK, L, S & T use one (1) 1AUX545 ASM Valve Seat Puller as shown on Page 23.
 For Models FXDM, Q & U use one (1) 2015080 ASM Valve Seat Puller as shown on Page 23.

Ø Not shown on illustration.

** Selective for Column 10.

Order by Part Number and Description. Reference Numbers for your convenience only.

N.D.S. Drilling Supply
 26041 Newton Circle
 Elko, MN 55020
 Phone #952-461-3400
 Fax # 952-461-3403

5 X 8 / 5-1/2 X 8

(FDFXX)
Models
 FXXB_B
 FXXC_B
 FXXF_B
 FXXG_B

Ref. No.	Name of Part	Qty. Req. Per Pump	Models
----------	--------------	--------------------	--------

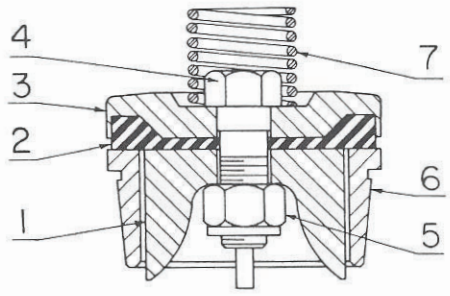

B75688

HARDENED STEEL
 WING GUIDED GRAVEL VALVE *
 WITH RUBBER INSERT
 SLUSH, GROUT & CEMENT SERVICE

Ref. #	Part Description	Qty.	Part No.
1	ASM VALVE less Seat, Incl.	8	200FGG482A
1	VALVE	8	200FGG482
2	INSERT	8	200FGG106
3	WASHER	8	200FGG279
4	BOLT	8	200FGG655
5	NUT	8	50AF8
6	SEAT	8	200FGG039
7	SPRING (Steel)	8	78A171
7	SPRING (Bronze)	8	78D22
Ø	COVER-VALVE	8	FD147
Ø	GASKET, Valve Cover.	8	25G18

For above valve use one (1) 200FGG219A ASM Valve Seat Puller as shown on Page 22.

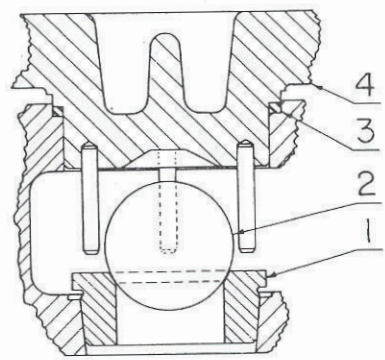

B75760

Ref. No.	Name of Part	Qty. Req. Per Pump	(FDFXX)	
			Models FXXS_B	Models FXXT_B

DELRIN BALL VALVE *
 GENERAL SERVICE
 (Optional)

Ref. No.	Part Description	Qty.	Part No. (Steel)	Part No. (Stainless Steel)
1	SEAT-VALVE	8	200FDD039	201FDD039
2	VALVE-BALL, Delrin	8	200FDD481	200FDD481
3	GASKET, Valve Cover.	8	25G18	25G18
4	COVER-VALVE.	8	200FDD147A	200FDD147A

For above Delrin Ball Valve use one (1) FDD67544 Valve Puller Group as shown on Page 23.

Ø Not shown on illustration.
 * Selective for Column 10

Order by Part Number and Description. Reference Numbers for your convenience only.

N.D.S. Drilling Supply
 26041 Newton Circle
 Elko, MN 55020
 Phone #952-461-3400
 Fax # 952-461-3403

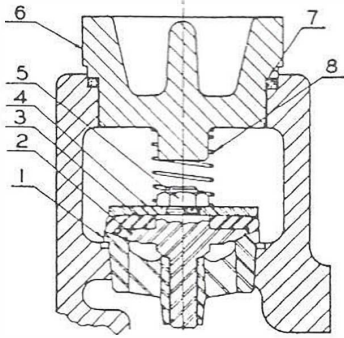

B37359

Ref.
No.

Name of Part

Qty.
Req.
Per
Pump

(FCFXX)	(FDFXX)	(FCFXX)
Models	Models	Models
FXXD_B	FXXB_B	FXXD_B
FXXH_B	FXXC_B	FXXH_B
	FXXF_B	
	FXXG_B	

HARDENED STEEL
 CENTER GUIDED VALVE **
 WITH RUBBER INSERT
 SLUSH, GROUT & CEMENT SERVICE

Part No. Part No. Part No.

1	SEAT-VALVE	8	PA451	1FG451	PA451
	ASM FLUID VALVE, Incl. Ref. #2 Thru 5.	8	EF482E*	1FG908	EF482G
2	VALVE-FLUID	8	EF482	3FG482	EF482
3	INSERT	8	6EF452	5FG452	7EF452
4	WASHER	8	3EF279	1FG279	3EF279
5	NUT	8	50V50	50G8	50V50
6	COVER-VALVE	8	9FC147	FD147	9FC147
7	GASKET, Valve Cover	8	25AL36	25G18	25AL36
8	SPRING	8	78A298	78A171	78A298

* With Polyurethane Insert.

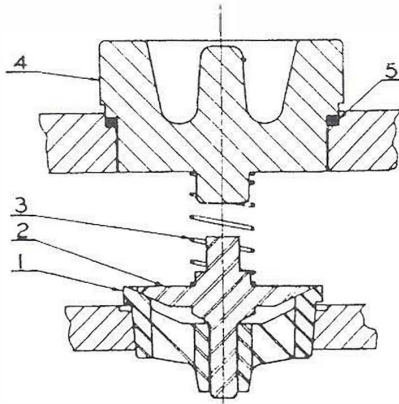

B37360

Ref.
No.

Name of Part

Qty.
Req.
Per
Pump

(FDFXX)	(FCFXX)
Models	Models
FXXK_B	FXXM_B
FXXL_B	FXXU_B
FXXS_B	
FXXT_B	

HARDENED STEEL
 CENTER GUIDED VALVE **
 WITHOUT INSERT
 OIL OR GENERAL SERVICE

Part No. Part No.

1	SEAT-VALVE	8	1FG451	PA451
2	VALVE-FLUID	8	3FG482	EF482
3	SPRING	8	78A134	78A299
4	COVER-VALVE	8	FD147	9FC147
5	GASKET, Valve Cover	8	25AV18	25AL36

For above valves use one (1) 3AUX545 ASM Valve Seat Puller as shown on Page 23.

** Selective for Column 10.