

Elevators, Links, Rings, Tong

SPECIAL TONG

For CFD-1, CFD-1B, 1250 & CF-15 Drills

This Type "S" special tong, designed as optional equipment for the **Failing** chain feed drills indicated, is basically similar to the type "S" lightweight tong described on Page 6, Section 13.

It is positioned above the rotary table by means of a permanently anchored, flexible, pivoted-mounting arrangement.

Parts List

Ref. No.	No. Req.	Description	Part Number	Weight Lbs. Oz.	
1	1	Arm, Tong	10825		
2	1	Jaw, Long, with Die	109F157	6	
3	1	Spring, Latch	109F163		2
4	3	Pin, Hinge	109F161		4
	1	Pin, Removable Hinge	109F162		6
	1	Pin, Cotter	4CP-20		
5	1	Jaw, Short	109F158	2	
6	1	Latch, Tong	10830	3	
7	2	Die, Tong Jaw	109F160		4
8	1	Jaw, Lug, w/Die, for 2 3/8" D.P.	10831		
8	1	Jaw, Lug, w/Die, for 2 7/8" D.P.	10831-A		
8	1	Jaw, Lug, w/Die, for 3" to 4 1/8" D.P.	10831-B		
9	1	Link, Short	10827	4	
10	3	Pin, Hinge	10829	2	8
11	1	Link, Long	10826		
12	3	Pin, Cotter	8CP-28		
13	1	Spring, Tong Link	14490		
14	2	Ear, Mounting	10828		
Assembly, Tong, for 2 3/8" Drill Pipe			109F885		
Assembly, Tong, for 2 7/8" Drill Pipe			109F886		
Assembly, Tong, for 3" to 4 1/8" Drill Pipe			109F887		

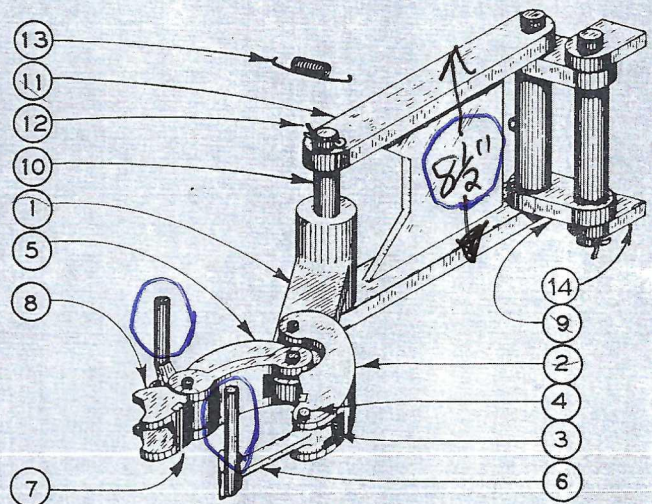

GEFCO