

GARDNER DENVER®

3-523
4th Edition
June, 1997

**DUPLEX POWER PUMP
6" STROKE**

MODEL

FXG__B

**Call:
NDS Drilling Supply, Inc
26041 Newton Circle
Elko New Market, MN 55020
1-800-637-1940
952-461-3400**

PARTS LIST

**Gardner
Denver**

**MAINTAIN PUMP RELIABILITY AND PERFORMANCE WITH
GENUINE GARDNER DENVER, AJAX AND OPI
PARTS AND SUPPORT SERVICES**

Gardner Denver[®], AJAX[®], and OPI[®] genuine pump parts are manufactured to original tolerances and designed for optimum dependability. Design and material innovations are the result of years of experience with hundreds of different pump applications. Reliability in materials and quality assurance are incorporated in our genuine replacement parts.

Your authorized Gardner Denver, AJAX and OPI distributor offers all the backup you'll need. A worldwide network of authorized distributors provides the finest product support in the pump industry.

Your local authorized distributor maintains a large inventory of genuine parts and he is backed up for emergency parts by the Gardner Denver Machinery Inc. Master Distribution Center (MDC) in Memphis, Tennessee.

Your authorized distributor can support your Gardner Denver, AJAX and OPI pump needs with these services:

1. Trained parts specialists to assist you in selecting the correct replacement parts.
2. A full line of factory tested pump lubricants specifically formulated for use in Gardner Denver, AJAX and OPI pumps.
3. Repair and maintenance kits designed with the necessary parts to simplify servicing your pump.

Authorized distributor service technicians are factory-trained and skilled in pump maintenance and repair. They are ready to respond and assist you by providing fast, expert maintenance and repair services.

For the location of your local authorized Gardner Denver, AJAX and OPI distributor refer to the yellow pages of your phone directory or contact:

Distribution Center:
Gardner Denver Machinery Inc.
Master Distribution Center
5585 East Shelby Drive
Memphis, TN 38141
Phone: (901) 542-6100
(800) 245-4946
Fax: (901) 542-6159

Factory:
Gardner Denver Machinery Inc.
1800 Gardner Expressway
Quincy, IL 62301
Phone: (217) 222-5400
Fax: (217) 224-7814

INSTRUCTIONS FOR ORDERING REPAIR PARTS

When ordering parts, specify Pump MODEL and SERIAL NUMBER (see nameplate on unit). The Serial Number is also stamped on top of the cylinder end of the frame (cradle area).

All orders for Parts should be placed with the nearest authorized distributor.

Where NOT specified, quantity of parts required per pump or unit is one (1); where more than one is required

per unit, quantity is indicated in parenthesis. **SPECIFY EXACTLY THE NUMBER OF PARTS REQUIRED.**

DO NOT ORDER BY SETS OR GROUPS.

To determine the Right Hand and Left Hand side of a pump, stand at the power end and look toward the fluid end. Right Hand and Left Hand are indicated in parenthesis following a part name, i.e. (RH) & (LH), when appropriate.

For Operating and Service Instructions see:

SERVICE MANUAL 3-600

TABLE OF CONTENTS

	Page
Maintain Pump Reliability and Performance With Genuine Gardner Denver Parts and Support Services	1
Instructions For Ordering Repair Parts	1
Menu/Matrix	3
Frame Group	4
Jackshaft	5
Oil Stop Head	6
Eccentric & Shaft	7
Eccentric Shaft Bearing	7
Connecting Rod & Crosshead	8
Fluid Cylinder	9
Stuffing Box	10
Stuffing Box Gland (Optional Equipment)	10
Steel Insert Type Piston – Standard For Slush, Grout & Cement Service	11
Solid Iron Type Piston With Cast Iron Rings – Standard For Oil Service	11
Cylinder Liners	12
Cup-type Pistons – Iron & Steel For Oil and General Service, Bronze For Water Service	12
Follower Type Fluid Piston For Water and General Service	13
Piston Rods & Nuts	13
Wing Guided Valve With Insert (Slush, Grout, Cement & Water Service)	14
Wing Guided Valve Without Insert (Oil or General Service)	15
Wing Guided Valve Without Insert (Oil, Water or General Service)	16
Wing Guided Gravel Valve With Rubber Insert (Slush, Grout & Cement Service)	17
Center Guided Valve Without Insert (Oil or General Service)	18
Center Guided Valve With Rubber Insert (Slush Service)	19
Durabla Valve, Stainless Steel, General Service (Optional)	20
Delrin Ball Valve, General Service (Optional)	21
Ball Guided Spherical Valve – Oil, Water or General Service (Optional)	22
Valve Seat Puller – Gravel Type (Optional Equipment)	22
Valve Seat Puller – Wing Guided & Delrin Ball (Optional Equipment)	23
Valve Seat Puller – Center Guided (Optional Equipment)	23
Surge Chamber – Discharge (Optional Equipment)	24
Surge Chamber – Suction (Optional Equipment)	24
Rod Wash (Optional Equipment)	25
Liner Puller (Optional Equipment)	25
Crosshead Pin Bushing Puller (Optional Equipment)	26
Relief Valves (Optional Equipment)	26

Order by Part Number and Description. Reference Numbers are for your convenience only.

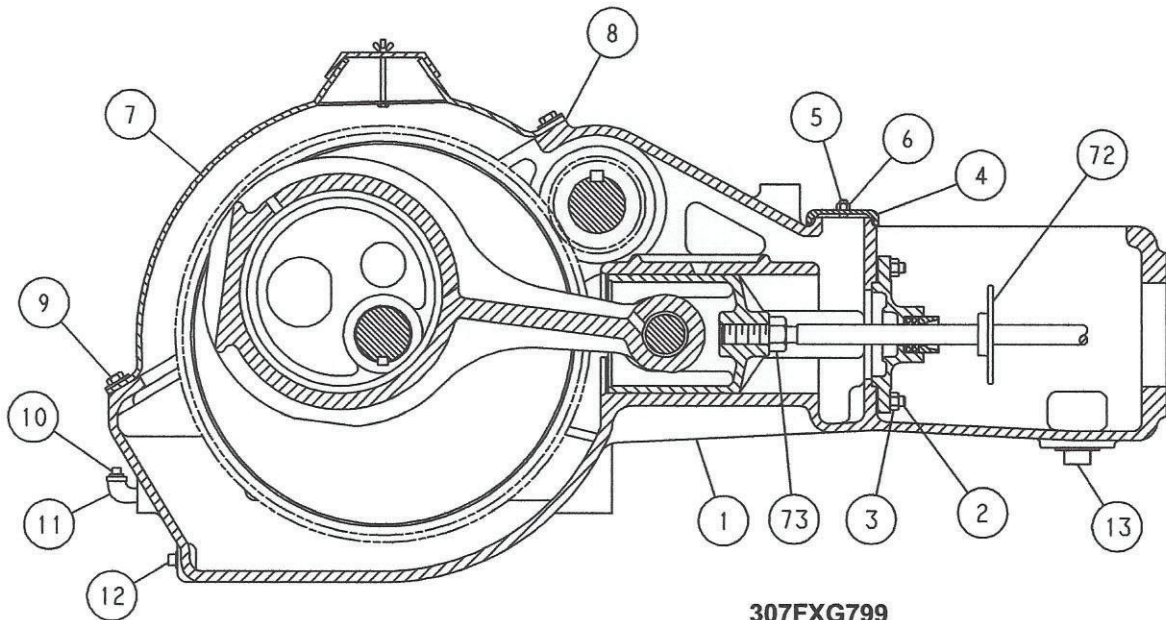

307FXG799
(Ref. Drawing)

FRAME GROUP

Ref. No.	Name of Part	Qty.	All FXG Models Part No.
	FRAME ASSEMBLY, Includes Ref. No. 1, 2, 3, 5, 6, 10, 11, 12 & 13 ..	1	1FXG172A
1	FRAME		
2	STUD, Oil Stop Head	4	79A238
3	NUT, Oil Stop Head	4	50B5
4	PLATE-INSPECTION	1	3AXG237
5	STUD, Inspection Plate	1	79A338
6	NUT, Inspection Plate Stud	1	50B3
7	HOOD	1	200FXG053
8	GASKET, Hood	1	2009457
9	SCREW, Hood	8	655EE040
10	PLUG, Oil Level	1	64AA4
11	ELBOW-PIPE STREET, Oil Level	1	64D4
12	PLUG, Oil Drain	1	64A5
13	PLUG, Frame Drain	1	64A9
72	BAFFLE, Piston Rod	2	1FXG840
73	NUT, CROSSHEAD	2	50T67
*	COVER-FRAME CRADLE (SOLID)	1	200FXG225
*	STUD-FRAME CRADLE COVER	2	79A466
*	NUT-FRAME CRADLE COVER STUD WING	2	50H1

* Not Shown.

Order by Part Number and Description. Reference Numbers are for your convenience only.

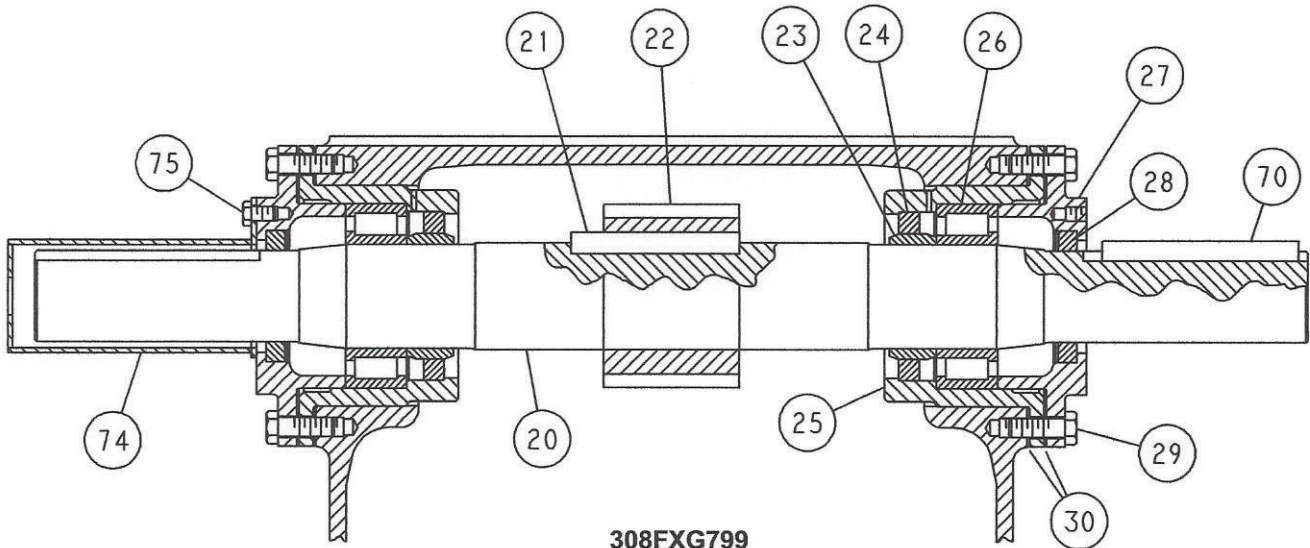

308FXG799
(Ref. Drawing)

JACKSHAFT

Ref. No.	Name of Part	Qty.	All FXG Models Part No.
	JACKSHAFT ASSEMBLY, Includes Ref. No. 20, 21 & 22	1	FXG374
20	JACKSHAFT	1	FXG371
21	KEY, Jackshaft to Gear	1	35C48
22	GEAR-DRIVEN	1	FXG181
23	SLEEVE-SHAFT	2	FXG289
24	SEAL-OIL, Bearing Housing	2	60G39
25	HOUSING-BEARING	2	FXG368
26	BEARING, Jackshaft	2	12W2
27	PLATE-BEARING RETAINING	2	FXG370
28	SEAL-OIL, Bearing Retaining Plate	2	60G40
29	SCREW, Housing & Retaining Plate	12	655EE060
30	GASKET, Housing & Retaining Plate	4	25C657
70	KEY-Jackshaft	1	35B166
74	COVER-SHAFT EXTENSION	1	201FXG490
75	SCREW, Shaft Extension Cover	3	75A68
*	FITTING-LUBRICATION	2	40E5

* Not Shown.

Order by Part Number and Description. Reference Numbers are for your convenience only.

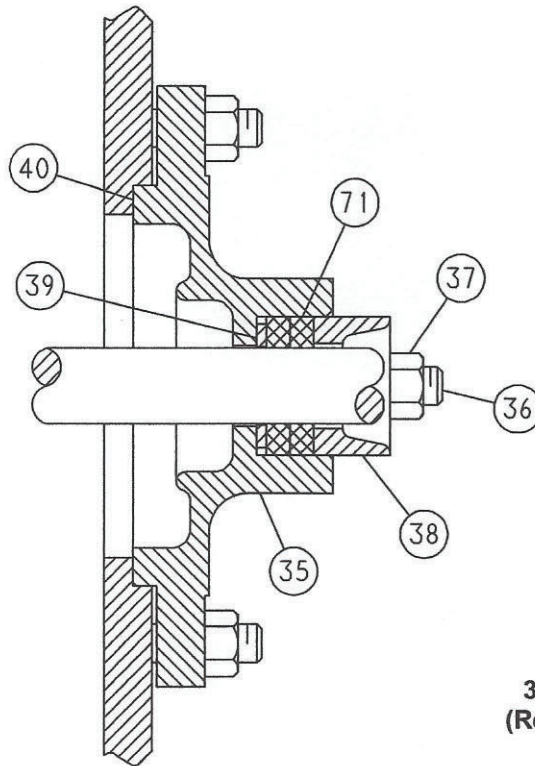

309FXG799
(Ref. Drawing)

OIL STOP HEAD

Ref. No.	Name of Part	Qty.	All FXG Models Part No.
	OIL STOP HEAD ASSEMBLY, Includes Ref. No. 35, 36 & 37	2	2FXG495
35	OIL STOP HEAD		
36	STUD, Oil Stop Head	4	79A238
37	NUT, Oil Stop Head Stud	4	50B5
38	GLAND, Oil Stop Head	2	AXG238
39	WASHER, Oil Stop Head	2	AG318
40	GASKET, Oil Stop Head	2	25C656
71	PACKING, Oil Stop Head	2	60BG24

Order by Part Number and Description. Reference Numbers are for your convenience only.

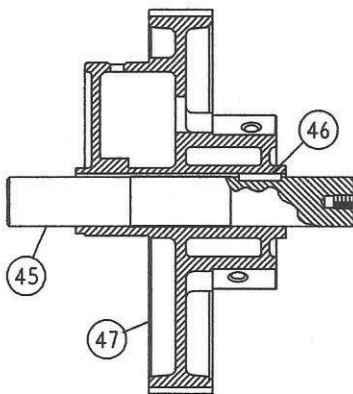

310FXG799
(Ref. Drawing)

ECCENTRIC & SHAFT

Ref. No.	Name of Part	Qty.	All FXG Models Part No.
45	SHAFT-ECCENTRIC	1	1FXG367
46	KEY	1	35C70
47	ECCENTRIC	1	1FXG255

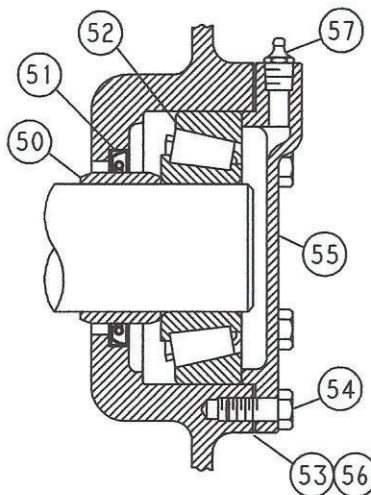

311FXG799
(Ref. Drawing)

ECCENTRIC SHAFT BEARING

Ref. No.	Name of Part	Qty.	All FXG Models Part No.
50	SLEEVE-SHAFT	2	16AUX18
51	SEAL-OIL	2	60G221
52	BEARING, Eccentric Shaft	2	12C30
53	SHIM, Bearing Cover Plate*	3	77G16
54	SCREW, Bearing Cover Plate	12	75AA1
55	PLATE-BEARING COVER	2	FXG366
56	GASKET, Bearing Cover Plate**	1	25C657
57	FITTING-LUBE	2	40E5

* Used opposite 25C657 Gasket.

** Used opposite 77G16 Shims.

Order by Part Number and Description. Reference Numbers are for your convenience only.

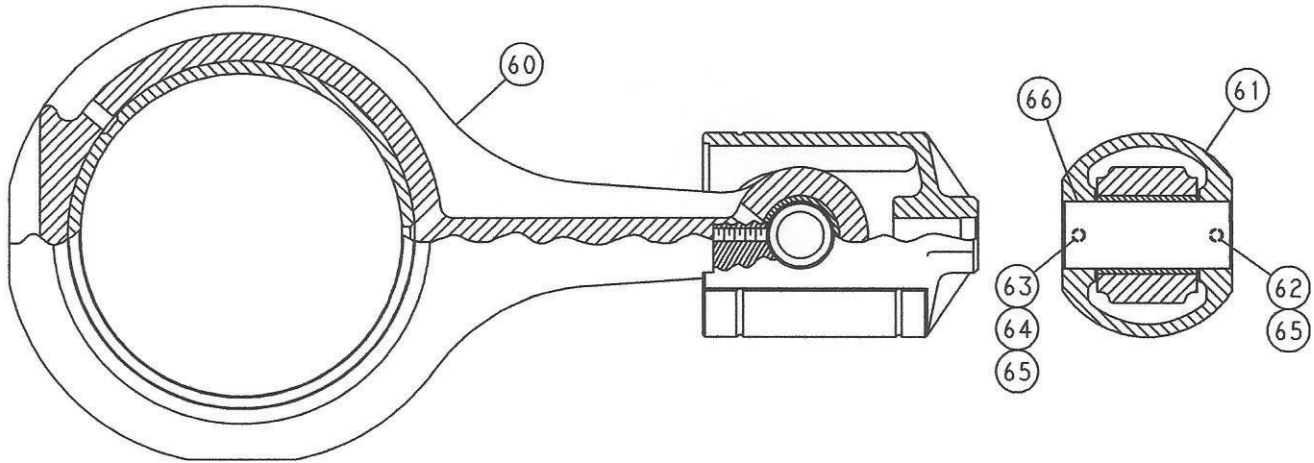

312FXG799
(Ref. Drawing)

CONNECTING ROD & CROSSHEAD

Ref. No.	Name of Part	Qty.	All FXG Models Part No.
60	CONNECTING ROD, Includes next two items	2	1FXG417
	BUSHING, Eccentric	2	3FXG421
	BUSHING, Crosshead Pin	2	AXG229
	CROSSHEAD ASSEMBLY, Includes Ref. No. 61 thru 65	2	FXG175X
61	CROSSHEAD		
62	SET SCREW-SOCKET HEAD	4	76J6
63	SET SCREW-SQUARE HEAD	2	76U32
64	PIN, Set Screw	4	62A152
65	NUT, Set Screw	2	50F3
66	PIN-CROSSHEAD	2	FXG189

Order by Part Number and Description. Reference Numbers are for your convenience only.

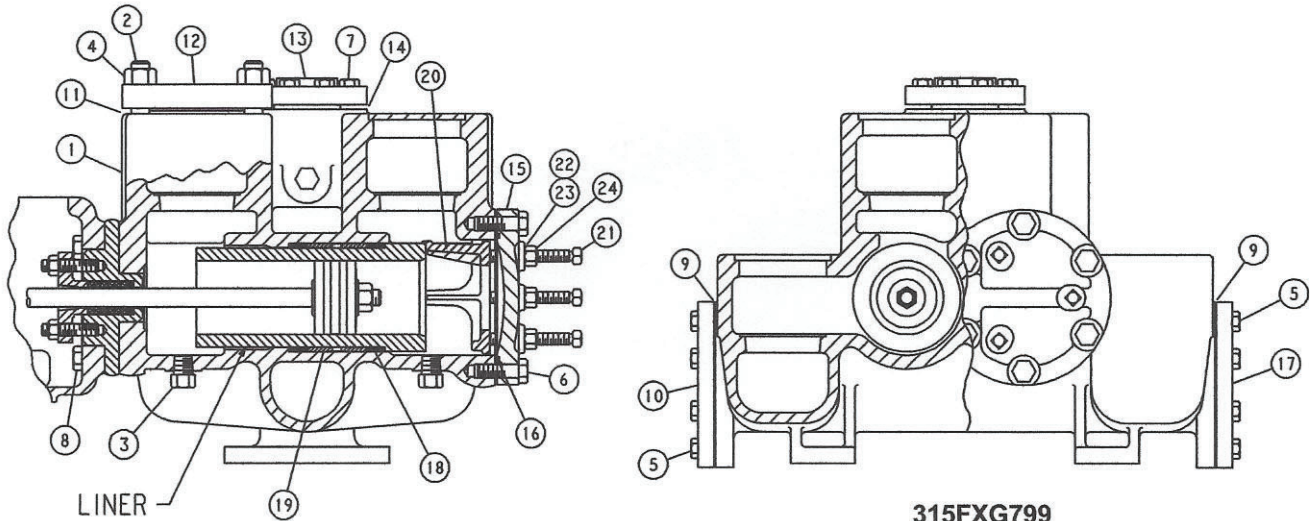

FLUID CYLINDER

Ref. No.	Name of Part	Qty.	ALL FXG Models Part No.
	FLUID CYLINDER ASSEMBLY, Includes Ref. No. 1, 4, 5, 6, 7 & 8	1	8FG29B
1	FLUID CYLINDER		
2	STUD, Valve Cover	16	79L40C
3	PLUG, Drain	5	64AU5
4	NUT , Valve Cover Stud	16	50B10C
5	SCREW,Suction & Blank Flange	16	655EF07Z
6	SCREW, Cylinder Head	10	655EG09Z
7	SCREW, Discharge Flange	8	655EF08Z
8	SCREW, Flange to Cylinder	6	655EG11Z
9	GASKET, Suction & Blank Flange	2	25C603N
10	FLANGE, Suction	1	FG92
11	GASKET, Valve Cover	8	25BE18
12	COVER-VALVE	8	3FG147
13	FLANGE, Discharge	1	64CE4
14	GASKET, Discharge Flange	1	25C502
15	HEAD-CYLINDER	1	1FG41
16	GASKET, Cylinder Head	2	25BE24
17	FLANGE, Suction	1	64DC8
18	GASKET, Liner	4	25T27
19	SPACER-LANTERN, Liner	2	1FG445
20	CLAMP-LINER	2	2FG217
21	SET SCREW, Liner Clamp	6	76N14
22	PACKING, Liner Clamp Set Screw	6	60BQ1
23	WASHER, Liner Clamp Set Screw	6	95F7
24	NUT, Liner Clamp Set Screw	6	50B7C
	LINER	2	See Page 12

Order by Part Number and Description. Reference Numbers are for your convenience only.

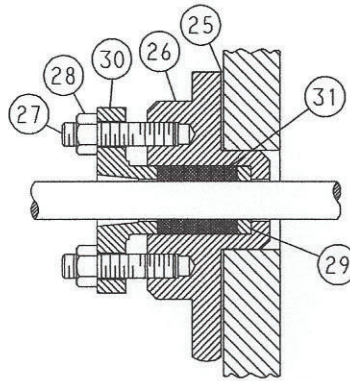

313FXG799
(Ref. Drawing)

STUFFING BOX

Ref. No.	Name of Part	Qty.	All FXG Models Part No.
	STUFFING BOX ASSEMBLY, Includes Ref. No. 26 thru 28	2	1FG1538
25	GASKET, Stuffing Box	2	25C658
26	STUFFING BOX		
27	STUD, Stuffing Box	4	79L125C
28	NUT, Stuffing Box Stud	4	50B7C
29	RING-JUNK	2	FG317
30	GLAND	2	FG21
31	PACKING, Molded Rubber & Duck	2	60DA310

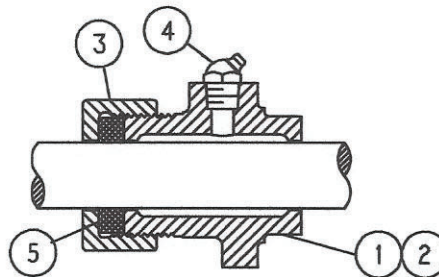

314FXG799
(Ref. Drawing)

**STUFFING BOX GLAND
(Optional Equipment)**

Ref. No.	Name of Part	Qty.	All FXG Models Part No.
1	GLAND ASSEMBLY, Includes Ref. No. 2 thru 5	2	200FXG008A
2	GLAND	2	200FXG008
3	NUT	2	200FXG086
4	FITTING-LUBE	2	40E10
5	PACKING-RING	2	60DD74
*	NUT	4	50AQ7C

* Not shown.

Order by Part Number and Description. Reference Numbers are for your convenience only.

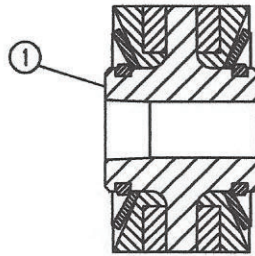

322FXG799
(Ref. Drawing)

**STEEL INSERT TYPE PISTON – STANDARD FOR SLUSH, GROUT & CEMENT SERVICE
(API NO. 1 TAPER)**

Ref. No.	Qty.	5" Part No.	Model FXGE_B	
			4-1/2" Part No.	4" Part No.
1	2	219TBA045A	217TBA045A	215TBA045A
	2	TBA76002	TBA76000	TBA75998
PISTON ASSEMBLY, Incl. next item INSERT GROUP, Includes Retainer Plates & Rings				

Ref. No.	Qty.	3-1/2" Part No.	Model FXGE_B	
			3" Part No.	2-1/2" Part No.
1	2	213TBA045A	211TBA045A	45R31
	2	TBA75996	TBA75994	45R8
PISTON ASSEMBLY, Incl. next item INSERT GROUP, Includes Retainer Plates & Rings				

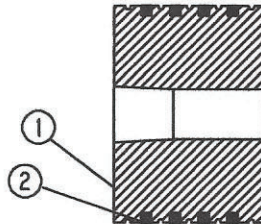

323FXG799
(Ref. Drawing)

**SOLID IRON TYPE PISTON WITH CAST IRON RINGS – STANDARD FOR OIL SERVICE
(API NO. 1 TAPER)**

Ref. No.	Size	Name of Part	Qty.	Model FXGC_B Part No.
1	5"	PISTON	2	200FXG350
2	5"	RING-PISTON	8	65A159
1	4-1/2"	PISTON	2	201FXG350
2	4-1/2"	RING-PISTON	8	65A1
1	4"	PISTON	2	202FXG350
2	4"	RING-PISTON	8	65A33
1	3-1/2"	PISTON	2	203FXG350
2	3-1/2"	RING-PISTON	8	65A9
1	3"	PISTON	2	204FXG350
2	3"	RING-PISTON	8	65A14
1	2-1/2"	PISTON	2	205FXG350
2	2-1/2"	RING-PISTON	8	65A44

Order by Part Number and Description. Reference Numbers are for your convenience only.

**CYLINDER LINERS
TWO (2) REQUIRED PER PUMP**

Size	All FXG Models			
	Bronze Part No.	Hardened Steel Part No.	Chrome Plated Part No.	Stainless Steel Part No.
5"	45FG64	FG45650	6FG45650	3FG45650
4-1/2"	44FG64	1FG45645	6FG45645	3FG45645
4"	43FG64	1FG45640	6FG45640	3FG45640
3-1/2"	42FG64	1FG45635	6FG45635	3FG45635
3"	41FG64	1FG45630	6FG45630	3FG45630
2-1/2"	200FGG456	1FG45625	6FG45625	3FG45625

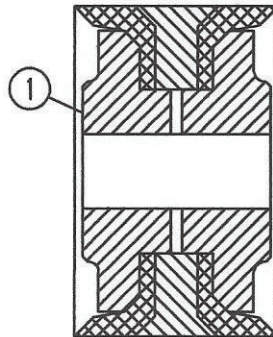

**325FXG799
(Ref. Drawing)**

**CUP-TYPE PISTONS – IRON & STEEL FOR OIL AND GENERAL SERVICE
BRONZE FOR WATER SERVICE
API NO. 1 TAPER (OPTIONAL)**

Ref. No.	Name of Part	Qty.	All FXG Models		
			5" Part No.	4-1/2" Part No.	4" Part No.
1	PISTON (Iron) Incl. following Cup ...	2	P1APIL500	P1APIL450	P1APIL400
1	PISTON (Steel) Incl. following Cup ..	2	P1APIL500S	P1APIL450S	P1APIL400S
1	PISTON (Bronze) Incl. following Cup .	2	P1APIL500B	P1APIL450B	P1APIL400B
	CUP	4	60BB15	60BB13	60BB11

Ref. No.	Name of Part	Qty.	All FXG Models		
			3-1/2" Part No.	3" Part No.	2-1/2" Part No.
1	PISTON (Iron) Incl. following Cup ...	2	P1APIL350	P1APIL300	P1APIL250
1	PISTON (Steel) Incl. following Cup ..	2	P1APIL350S	P1APIL300S	P1APIL250S
1	PISTON (Bronze) Incl. following Cup .	2	P1APIL350B	P1APIL300B	P1APIL250B
	CUP	4	60BB9	60BB7	60BB33

Order by Part Number and Description. Reference Numbers are for your convenience only.

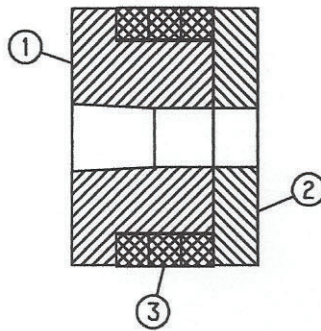

324FXG799
(Ref. Drawing)

**FOLLOWER TYPE FLUID PISTON
FOR WATER AND GENERAL SERVICE
(API NO. 1 TAPER)**

Model FXGD_B & FXGE_B

Ref. No.	Description	Qty.	Model FXGD_B & FXGE_B		
			5" Part No.	4-1/2" Part No.	4" Part No.
1	BODY-PISTON (Iron)	2	204FXG045	6FG45	26AXG45
2	FOLLOWER-PISTON (Iron)	2	204FXG046	4FG46	9AXG46
1	BODY-PISTON (Bronze)	2	205FXG045	7FG45	27AXG45
2	FOLLOWER-PISTON (Bronze)	2	205FXG046	5FG46	10AXG46
3	PACKING, Regular Cure	6	60D15	60D16	60D17
3	PACKING, Rock Hard	6	60Y15	60Y16	60Y17

Ref. No.	Description	Qty.	Model FXGD_B & FXGE_B		
			3-1/2" Part No.	3" Part No.	2-1/2" Part No.
1	BODY-PISTON (Iron)	2	202FXG045	28AXG45	200FXG045
2	FOLLOWER-PISTON (Iron)	2	202FXG046	3AXG46	200FXG046
1	BODY-PISTON (Bronze)	2	203FXG045	29AXG45	201FXG045
2	FOLLOWER-PISTON (Bronze)	2	203FXG046	4AXG46	201FXG046
3	PACKING, Regular Cure	6	60D25	60D11	60D27
3	PACKING, Rock Hard	6	60Y25	60Y11	60Y27

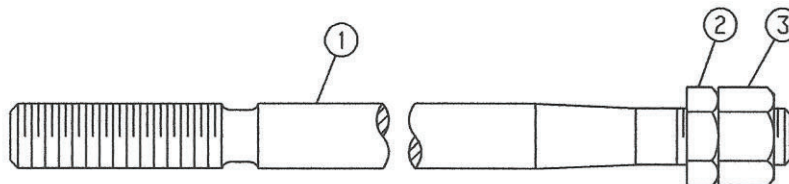

301FXG810
(Ref. Drawing)

PISTON RODS & NUTS (API NO. 1 TAPER)

Ref. No.	Description	Qty.	All FXG Models			
			Bronze Part No.	Hardened Steel Part No.	Chrome Plated Part No.	Stainless Steel Part No.
1	PISTON, ROD, Incl. Ref. No. 2 & 3	2	33FXG183	25FXG183	42FXG183	32FXG183
2	NUT (Thin)	2	50Y9	None	None	50T60
3	NUT (Full)	2	50X11	50V2	50V2	50U9

Order by Part Number and Description. Reference Numbers are for your convenience only.

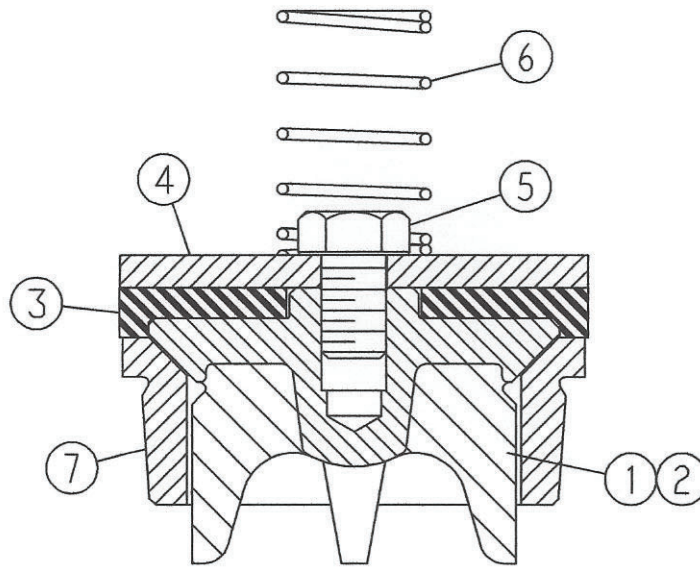

300FXG799
(Ref. Drawing)

**WING GUIDED VALVE
WITH INSERT
(SLUSH, GROUT, CEMENT & WATER SERVICE)**

Ref. No.	Name of Part	Qty.	Models		Models	
			FXGA_B FXGB_B Part No.	Model FXGD_B Part No.	FXGA_B FXGB_B Part No.	FXGA_B FXGB_B Part No.
			Hardened Steel, Rubber Insert	Bronze, Rubber Insert	Hardened Steel, Poly- urethane Insert	
1	ASSEMBLY, Includes Ref. No. 2 thru 5	8	1FG928	21FG206A	17FG206F	
2	VALVE-FLUID	8	17FG206	21FG206	17FG206	
3	INSERT	8	1FG452	1FG452	7FG452	
4	WASHER	8	95D49	95G11	95D49	
5	SCREW	8	5FF156	7FF156	5FF156	
6	SPRING	8	78A171	78D72	78A171	
7	SEAT-VALVE	8	11FG39	9FG39	11FG39	

Order by Part Number and Description. Reference Numbers are for your convenience only.

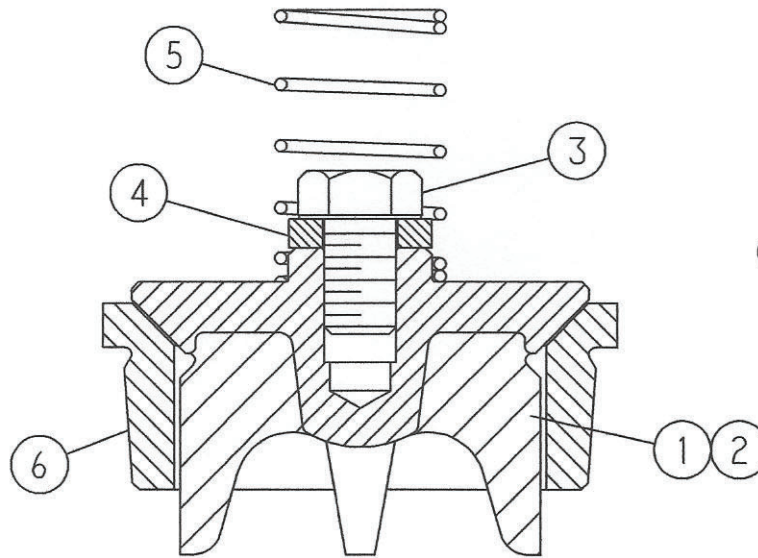

301FXG799
(Ref. Drawing)

**WING GUIDED VALVE
HARDENED STEEL WITHOUT INSERT
(OIL OR GENERAL SERVICE)**

Ref. No.	Name of Part	Qty.	Models FXGC_B FXGE_B Part No.
1	FLUID VALVE ASSEMBLY, Includes Ref. Nos. 2, 3 & 4	8	17FG206C
2	FLUID VALVE	8	17FG206
3	SCREW	8	5FF156
4	WASHER	8	95D136
5	SPRING	8	78A134
6	SEAT-VALVE	8	11FG39

Order by Part Number and Description. Reference Numbers are for your convenience only.

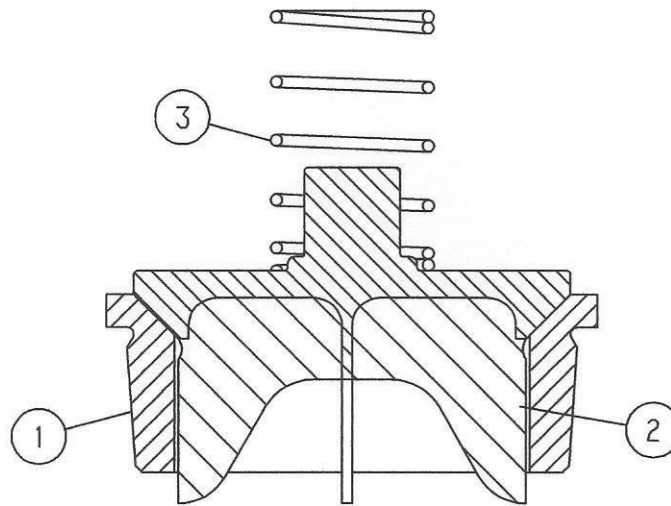

304FXG799
(Ref. Drawing)

**WING GUIDED VALVE
WITHOUT INSERT
(OIL, WATER OR GENERAL SERVICE)**

Ref. No.	Name of Part	Qty.	Models	
			FXGC_B FXGD_B FXGE_B Part No.	Model FXGD_B Part No.
			Iron Fitted	Brass Fitted
1	SEAT-VALVE	8	FG39	9FG39
2	VALVE-FLUID	8	FG69	1FG69
3	SPRING	8	78A172	78D72

Order by Part Number and Description. Reference Numbers are for your convenience only.

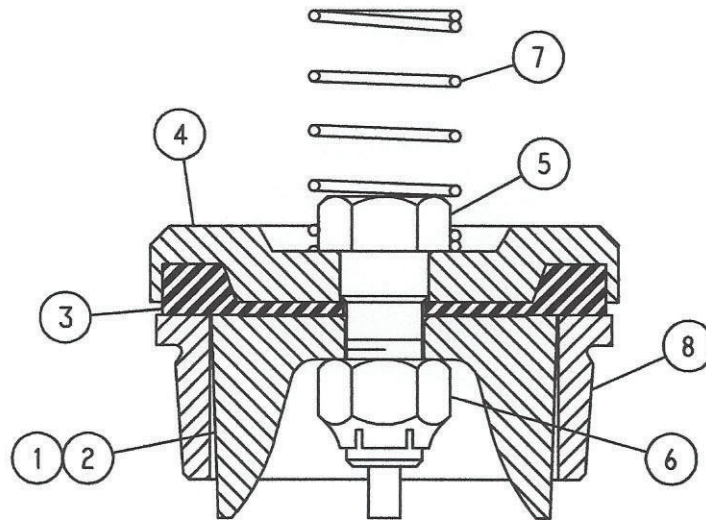

305FXG799
(Ref. Drawing)

**WING GUIDED GRAVEL VALVE
HARDENED STEEL WITH RUBBER INSERT
(SLUSH, GROUT & CEMENT SERVICE)**

Ref. No.	Name of Part	Qty.	Models FXGA_B FXGB_B Part No.
1	FLUID VALVE ASSEMBLY, Includes Ref. No. 2 thru 6	8	200FGG482A
2	VALVE-FLUID	8	200FGG482
3	INSERT	8	200FGG106
4	WASHER-VALVE	8	200FGG279
5	SCREW	8	200FGG655
6	LOCKNUT	8	50AF8
7	SPRING (Steel)	8	78A171
8	SEAT	8	200FGG039

Order by Part Number and Description. Reference Numbers are for your convenience only.

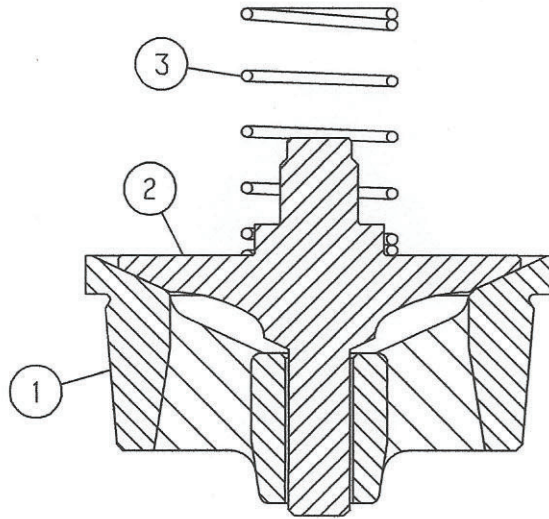

303FXG799
(Ref. Drawing)

**CENTER GUIDED VALVE
HARDENED STEEL WITHOUT INSERT
(OIL OR GENERAL SERVICE)**

Ref. No.	Name of Part	Qty.	Models FXGC_B FXGE_B Part No.
1	SEAT-VALVE	8	1FG451
2	VALVE-FLUID	8	3FG482
3	SPRING	8	78A134

Order by Part Number and Description. Reference Numbers are for your convenience only.

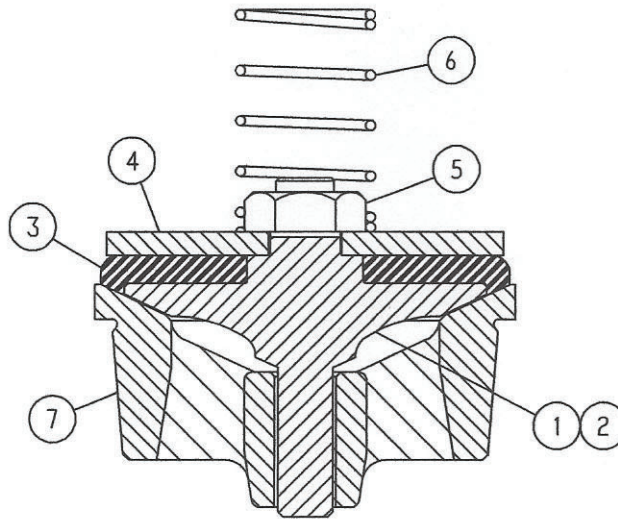

302FXG799
(Ref. Drawing)

**CENTER GUIDED VALVE
HARDENED STEEL WITH RUBBER INSERT
(SLUSH SERVICE)**

Ref. No.	Name of Part	Qty.	Model FXGA_B Part No.
1	FLUID VALVE ASSEMBLY, Includes Ref. No. 2 thru 5	8	1FG908
2	VALVE-FLUID	8	3FG482
3	INSERT	8	5FG452
4	WASHER	8	1FG279
5	NUT	8	50G8
6	SPRING	8	78A171
7	SEAT-VALVE	8	1FG451

Order by Part Number and Description. Reference Numbers are for your convenience only.

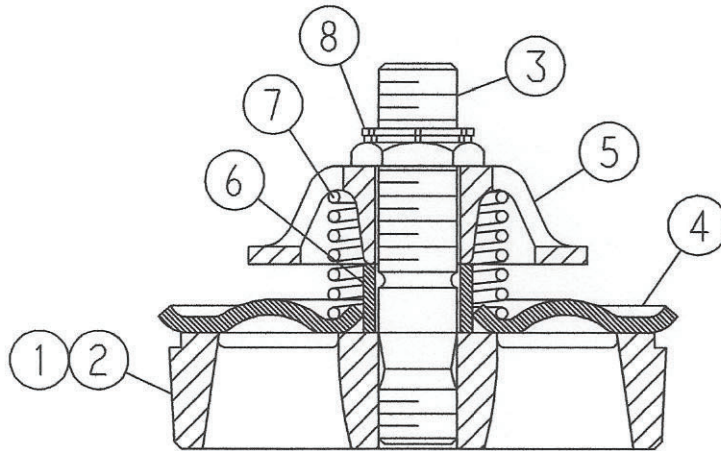

326FXG799
(Ref. Drawing)

**DURABLA VALVE
STAINLESS STEEL
GENERAL SERVICE (OPTIONAL)**

Ref. No.	Name of Part	Qty.	Model FXGE_B Part No.
1	FLUID VALVE ASSEMBLY, Includes Ref. Nos. 2 thru 8	8	2FG1602
2	SEAT-VALVE, Includes Ref. No. 3 **	8	18FG39A
3	STUD **	8	79AG14
4	DISC	8	90AN23
5	GUARD	8	50AK11
6	SLEEVE	8	80K10
7	SPRING	8	78R3
8	NUT	8	50AK14
*	COVER-VALVE ***	8	7FG147

* Not shown.

** Stud furnished with Seat may be purchased separately.

*** Durabla valves require the above 7FG147 listed cover in place of valve covers shown on the cylinder list.

Order by Part Number and Description. Reference Numbers are for your convenience only.

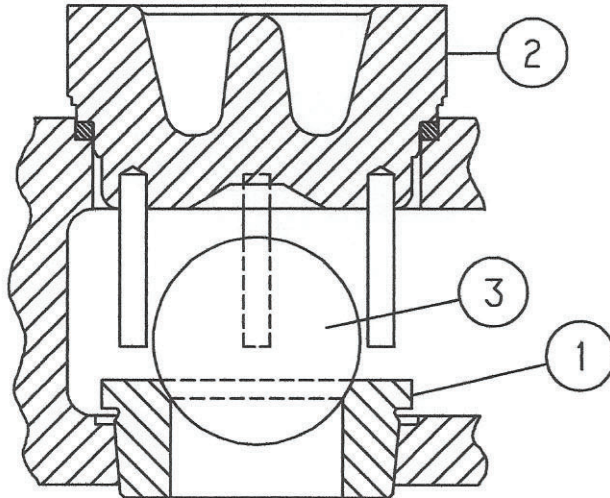

306FXG799
(Ref. Drawing)

**DELRIN BALL VALVE
GENERAL SERVICE (OPTIONAL)**

Ref. No.	Name of Part	Qty.	Model FXGE_B	
			Part No.	Part No.
			Steel	Stainless Steel
1	SEAT-VALVE	8	200FDD039	201FDD039
2	COVER-VALVE *	8	201FGG147A	201FGG147A
3	VALVE-BALL, Delrin	8	200FDD481	200FDD481

* Ball valve requires the above listed 201FGG147A Covers in place of valve covers shown on the cylinder list.

NOTE: See page 9 for Valve Cover Gasket.

Order by Part Number and Description. Reference Numbers are for your convenience only.

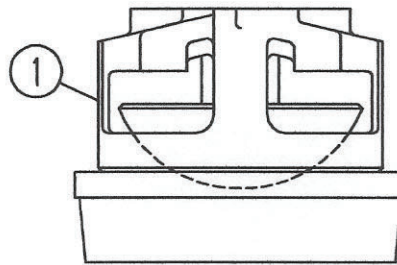

302FXG810
(Ref. Drawing)

**BALL GUIDED SPHERICAL VALVE
OIL, WATER OR GENERAL SERVICE (OPTIONAL)**

Ref. No.	Name of Part	Qty.	Models	Model	Model
			FXGC_B FXGE_B Part No.	FXGD_B Part No.	FXGE_B Part No.
			Steel	Bronze	Stainless Steel
1	FLUID VALVE ASSEMBLY	8	3FG1614	FG1614	6FG1614
*	COVER-VALVE, FLUID CYLINDERS ** ..	8	7FG147	7FG147	7FG147

* Not shown on drawing.

** Ball Guided Spherical valves require the above listed 7FG147 Cover in place of valve covers shown on cylinder list.

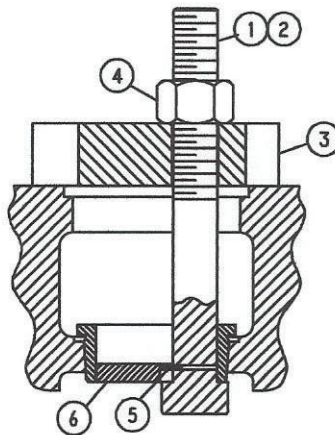

316FXG799
(Ref. Drawing)

**VALVE SEAT PULLER - GRAVEL TYPE
(Optional Equipment)**

Ref. No.	Name of Part	Qty.	All FXG Models Part No.
1	ASSEMBLY PULLER, VALVE SEAT (Includes 2, 3, 4, 5 & 6)	1	200FGG219A
2	BOLT-PULLER	1	2015079
3	PLATE-PULLER	1	3AUX292
4	NUT-HEX	1	50T62
5	PIN-SPRING ROLL	1	62R40
6	PULLER, Valve Seat	1	200FGG219

Order by Part Number and Description. Reference Numbers are for your convenience only.

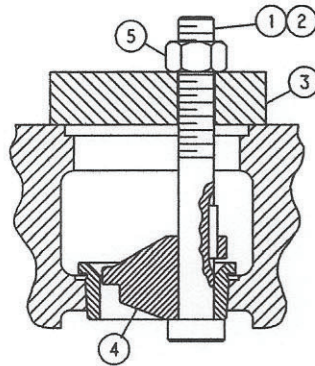

317FXG799
(Ref. Drawing)

VALVE SEAT PULLER – WING GUIDED & DELRIN BALL
(Optional Equipment)

Ref. No.	Name of Part	Qty.	All FXG Models	
			Part No.	Part No.
			Wing Guided	Derlin Ball
1	PULLER ASSEMBLY, Includes Ref. No. 2, 3, 4 & 5	1	1AUX545	FDD67544
2	BOLT-PULLER	1	2AUX235	2AUX235
3	PLATE-PULLER	1	2AUX292	2AUX292
4	PULLER	1	3AUX291	200FDD219
5	NUT	1	50C11	50C11

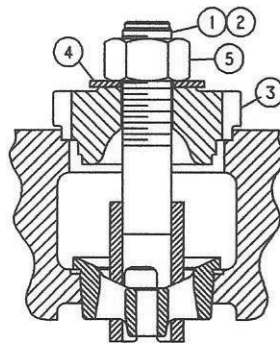

318FXG799
(Ref. Drawing)

VALVE SEAT PULLER – CENTER GUIDED
(Optional Equipment)

Ref. No.	Name of Part	Qty.	All FXG Models
			Part No.
1	PULLER ASSEMBLY, Includes Ref. No. 2, 3, 4 & 5	1	3AUX545
2	PULLER	1	AUX549
3	PLATE-PULLER	1	4AUX292
4	WASHER	1	95A22
5	NUT	1	50T161

Order by Part Number and Description. Reference Numbers are for your convenience only.

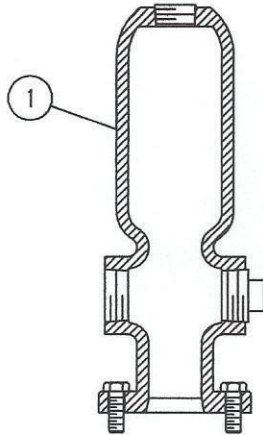

319FXG799
(Ref. Drawing)

SURGE CHAMBER – DISCHARGE
(Optional Equipment)

Ref. No.	Name of Part	Qty.	All FXG Models Part No.
1	SURGE CHAMBER ASSEMBLY, Includes next 3 items	1	1FF44X
	PLUG–CSK. PIPE, Top	1	64B6
	PLUG–SqHd PIPE, Side	1	64A9
	SCREW	8	655EF07Z

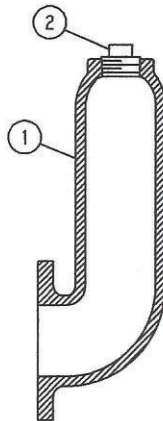

320FXG799
(Ref. Drawing)

SURGE CHAMBER – SUCTION
(Optional Equipment)

Ref. No.	Name of Part	Qty.	All FXG Models Part No.
1	SURGE CHAMBER	1	FG44
2	PLUG	1	64AJ15

Order by Part Number and Description. Reference Numbers are for your convenience only.

**ROD WASH
(Optional Equipment)**

Name of Part	Qty.	All FXG Models Part No.
MANIFOLD-WATER	1	1FXX315
SCREW	2	655ED030
NIPPLE	2	63D2
NIPPLE	2	63D37
VALVE-ANGLE	2	90F4
COVER-FRAME CRADLE	1	201FXG225
STUD-FRAME CRADLE COVER	2	79A466
NUT-FRAME CRADLE COVER STUD WING	2	50H1
ELBOW-90° STREET	2	64D2

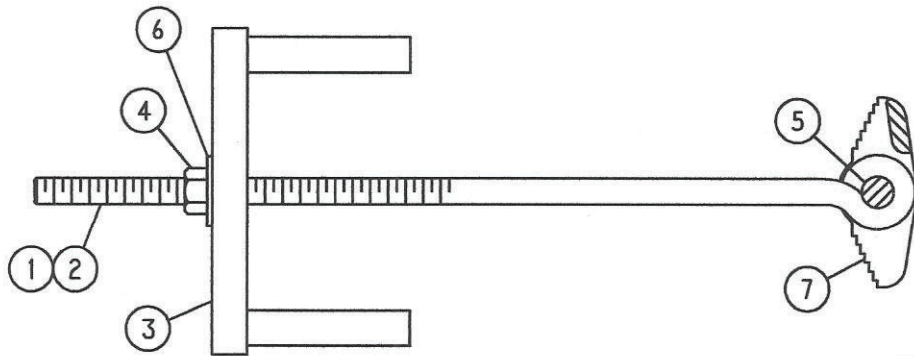

**300FXG810
(Ref. Drawing)**

**LINER PULLER
(Optional Equipment)**

Ref. No.	Name of Part	Qty.	All FXG Models Part No.
1	PULLER ASSEMBLY, Includes Ref. No. 2, 3, 4, 5, 6 & 7	1	1FG284
2	BOLT-PULLER	1	FG344
3	TOOL, Liner Puller	1	1FG346
4	NUT	1	50B8
5	PIN	1	62A93
6	WASHER	1	95A8
7	PULLER	1	1FG345

Order by Part Number and Description. Reference Numbers are for your convenience only.

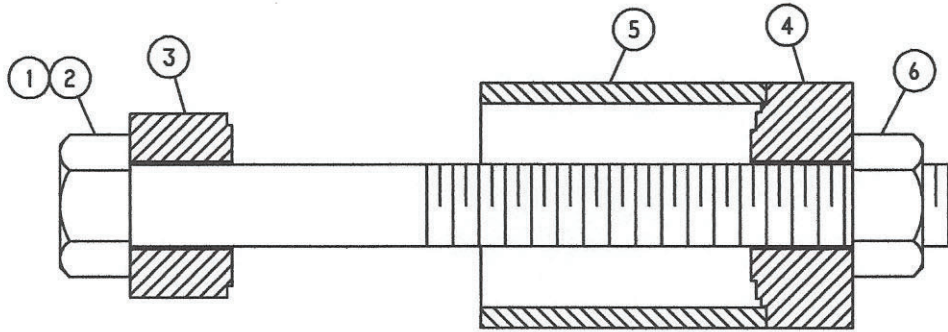

321FXG799
(Ref. Drawing)

CROSSHEAD PIN BUSHING PULLER
(Optional Equipment)

Ref. No.	Name of Part	Qty.	All FXG Models Part No.
1	PULLER ASSEMBLY, Includes Ref. No. 2, 3, 4, 5 & 6	1	FXG1585
2	BOLT-PULLER	1	FXG1279
3	PLATE	1	FXG1277
4	PLATE-PULLER	1	FXG1276
5	BUSHING	1	FXG1278
6	NUT	1	50T67

RELIEF VALVES
(Optional Equipment)

Name of Part	Qty.	All FXG Models Part No.
RELIEF VALVE (2" MPT) 125# - 150#	1	5825319
RELIEF VALVE (2" MPT) 500# - 1375#	1	187922

Gardner

Denver

For additional information contact your local representative or
Gardner Denver Machinery Inc., Customer Service Department,
1800 Gardner Expressway, Quincy, Illinois 62301
Telephone: (800) 682-9868 FAX: (217) 224-7814



Sales and Service in all major cities.

For parts information, contact Gardner Denver,
Master Distribution Center, Memphis, TN
Telephone: (800) 245-4946 FAX: (901) 542-6159

Specifications subject to change without notice.
Copyright 1996 Gardner Denver Machinery Inc.

Litho in U.S.A.