

# Mission Magnum I Pumps

**Installation, Operation  
and Maintenance  
Instructions**

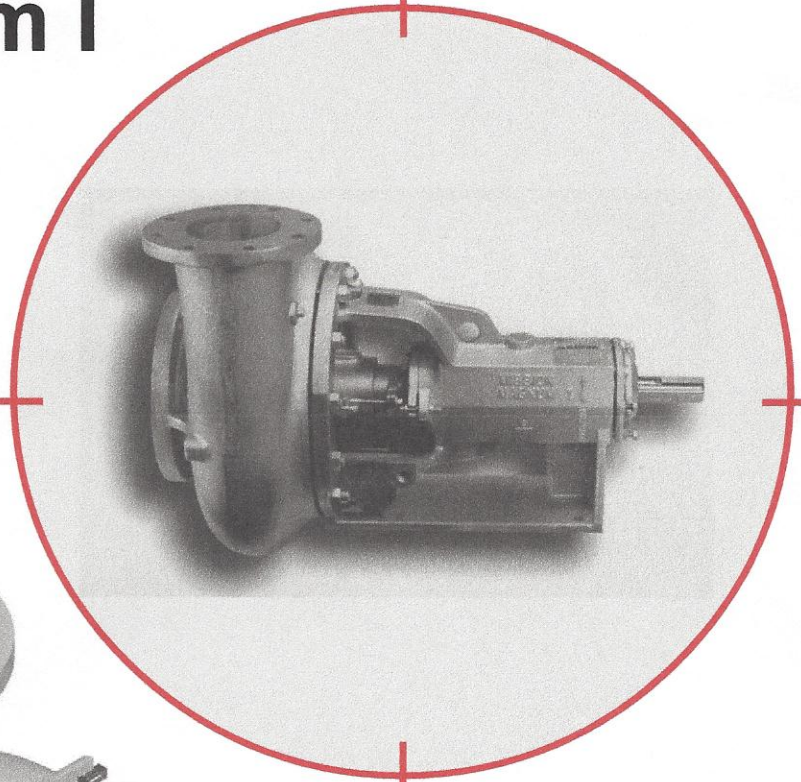

**Distributor Contact:  
NDS Drilling Supply,  
26041 Newton Circle  
Elko New Market,  
MN 55020  
1-800-637-1940  
952-461-3400**

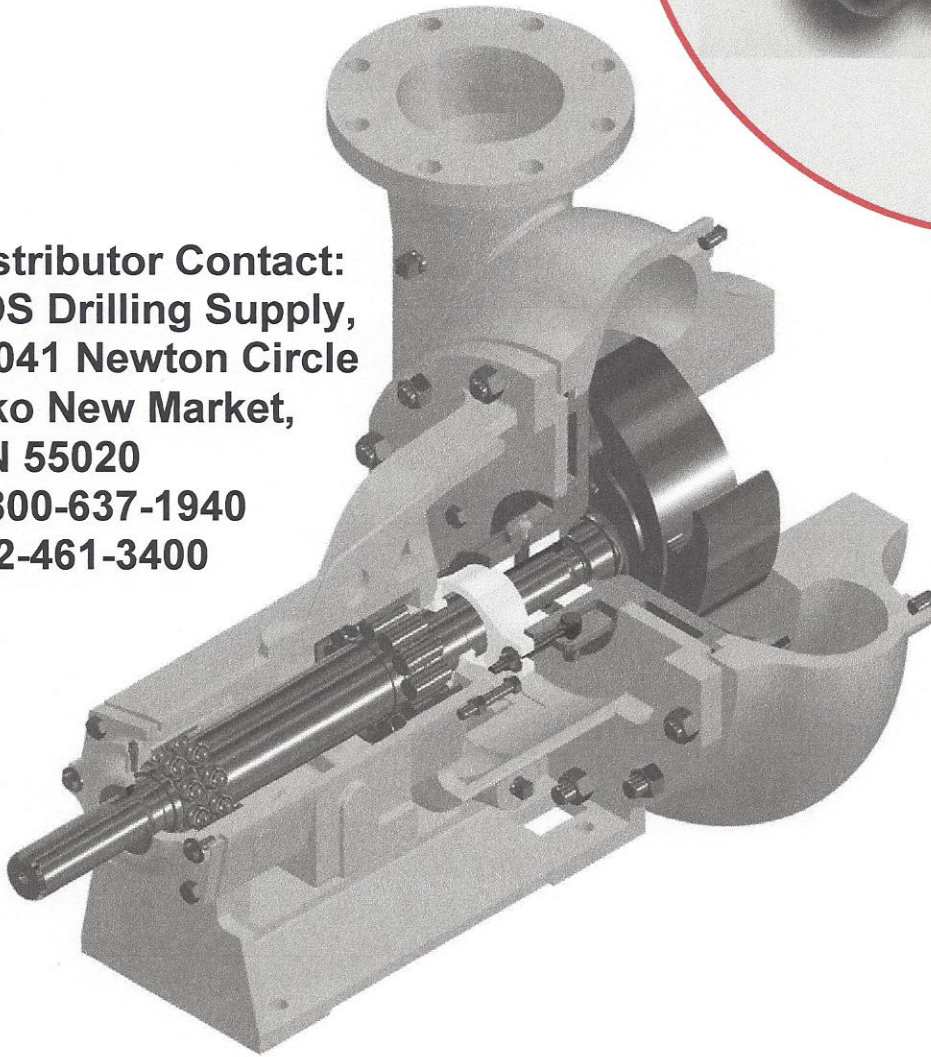

**Bulletin No.  
M203-3C**

## Foreword...

This manual contains instructions for the installation, operation and maintenance of the Mission Magnum I Pump. As pump service conditions and specifications vary considerably in pump installations, this manual cannot possibly cover every situation, but it is hoped that the information included will serve as a guide. Should questions arise, or start-up problems occur, it is suggested that you contact the Mission Pump Distributor or Salesman in your area.

The Magnum I pump generation is an improved version of the older Mission S & W pump line. The Magnum I pump is designed to give longer service life through heavier fluid end parts, heavier shaft bearings and reduced hydraulic loads.

There are many principles of proper pump installation and application as well as special considerations for the Magnum I design which, if followed, will further enhance the performance of your Magnum I pump.

This document will deal with both general and specific recommendations for improved Magnum I performance in both oilfield and industrial applications.

### GENERAL INSTRUCTIONS

1. Operate the pump only in the performance range for which it was designed.
2. When operating in drilling mud, prevent packing drippage from clogging the drip pan and hardening around the slinger and front seal area.
3. Adjust the packing so that a small amount of leakage remains for lubrication and cooling.
4. See "Maintenance, Assembly" Section F in this manual for Mechanical Seal Installation.

 **! CAUTION ! CAUTION ! CAUTION !** 

EXERCISE SAFETY IN ALL PERFORMANCES: DO NOT IGNORE ANY WARNINGS, USE ONLY APPROVED METHODS, MATERIALS AND TOOLS. DO NOT PERMIT ANY FUNCTION OF QUESTIONABLE SAFETY; ACCIDENTS ARE CAUSED BY UNSAFE ACTS AND UNSAFE CONDITIONS. SAFETY IS YOUR BUSINESS AND YOU ARE INVOLVED.

 **! WARNING ! WARNING ! WARNING !** 

BEFORE PERFORMING ANY SERVICE FUNCTION, BE CERTAIN THAT THE UNIT IS SEPARATED FROM ITS POWER SOURCE OR THAT THE POWER SOURCE IS LOCKED-OUT TO PREVENT ANY FORM OF ENERGY FROM ENTERING THE EQUIPMENT. THIS WOULD INCLUDE ELECTRICAL OR MECHANICAL ENERGY INTO OR FROM THE PRIME MOVER(S), PNEUMATIC ENERGY FROM THE COMPRESSOR/AIR SYSTEM, ETC.

**! WARNING ! WARNING ! WARNING !**

FAILURE TO OBSERVE THE WARNINGS AND NOTES OF CAUTION IN THIS PUBLICATION CAN RESULT IN PROPERTY DAMAGE, SERIOUS BODILY INJURY, OR DEATH.

**! ATTENTION - NOTICE - IMPORTANT !**

THESE TERMS ARE USED TO DRAW ATTENTION TO ACTION THAT WILL CAUSE DAMAGE TO THE PUMP, COMPONENTS OR ATTACHMENTS.

**! WARNING ! WARNING ! WARNING !**

**BEFORE SERVICING PUMPS:**

1. SHUT DOWN OR DISENGAGE THE PUMP POWER SOURCE.
2. SHUT DOWN ALL PUMP ACCESSORY EQUIPMENT.
3. RELIEVE OR "BLEED OFF" ALL PRESSURE FROM THE LINES PRIOR TO REMOVING PIPING.





FAILURE TO SHUT DOWN POWER AND RELIEVE PRESSURE FROM THE PUMP BEFORE SERVICING CAN RESULT IN SERIOUS PERSONAL INJURY AND PROPERTY DAMAGE.

## **ATEX Warning Statements**

### **Pumps and Pump Units**

1. Where a pump or pump unit is to be installed in a potentially explosive atmosphere ensure that this has been specified at the time of purchase and that the equipment has been supplied accordingly and displays an ATEX nameplate or is supplied with a certificate of conformity. If there is any doubt as to the suitability of the equipment please contact National Oilwell before commencing with installation and commissioning.
2. Process liquids or fluids should be kept within specified temperature limits otherwise the surface of pump or system components may become an ignition source due to temperature rises. Where the process liquid temperature is less than 90°C the maximum surface temperature will not exceed 90°C provided the pump is installed, operated and maintained in accordance with this manual.
3. Electrical installation and maintenance work should only be carried out by suitably qualified and competent persons and must be in accordance with relevant electrical regulations.
4. All electrical equipment, including control and safety devices, should be suitably rated for the environment into which they are installed.
5. Where there may be a risk of an accumulation of explosive gases or dust non-sparking tools should be used for installation and maintenance.
6. To minimize the risk of sparking or temperature rises due to mechanical or electrical overload the following control and safety devices should be fitted. A control system that will shut the pump down if the motor current or temperature exceed specified limits. An isolator switch that will disconnect all electrical supply to the motor and ancillary electrical equipment and be capable of being locked in the off position. All control and safety devices should be fitted, operated and maintained in accordance with the manufacturer's instructions. All valves on the system should be open when the pump is started otherwise serious mechanical overload and failure may result.
7. It is important that the pump rotates in the direction indicated on the nameplate. This must be checked on installation and commissioning and after any maintenance has been carried out. Failure to observe this may lead to dry running or mechanical or electrical overload.
8. When fitting drives, couplings, belts, pulleys and guards to a pump or pump unit it is essential that these are correctly fitted, aligned and adjusted in accordance with the manufacturer's instructions. Failure to do so may result in sparking due to unintended mechanical contact or temperature rises due to mechanical or electrical overload or slipping of drive belts. Regular inspection of these parts must be carried out to ensure they are in good condition and replacement of any suspect part must be carried out immediately.
9. Mechanical seals should be suitably rated for the environment. The seal and any associated equipment, such as a flushing system, must be installed, operated and maintained in accordance with the manufacturer's instructions.
10. Where a packed gland seal is fitted this must be correctly fitted and adjusted. This type of seal relies on the process liquid to cool the shaft and packing rings so a constant drip of liquid from the gland section is required. Where this is undesirable an alternative seal type should be fitted.
11. Failure to operate or maintain the pump and ancillary equipment in line with the manufacturer's instructions may lead to premature and potentially dangerous failure of components. Regular inspection, and where necessary, replacement of bearings and lubrication is essential.
12. The pump and its components have been designed to ensure safe operation within the guidelines covered by legislation. Accordingly National Oilwell has declared the machine safe to use for the duty specified as defined by the Declaration of Incorporation or Conformity that is issued with this instruction manual.

13. Sample nameplate:

 <b>NATIONAL OILWELL VARCO</b>		<b>MISSION PRODUCTS</b> P.O. BOX 4638 HOUSTON, TEXAS U.S.A. 77210-4638	
  II 2G c T5 TCF: ATEX 0001			
<input type="text"/> PUMP PART NO.		<input type="text"/> IMPELLER DESCRIPTION	
<input type="text"/> SIZE	<input type="text"/> INSTLD. IMP.	<input type="text"/> GPM	<input type="text"/> TDH-FT.
<input type="text"/> RPM	<input type="text"/> FLUID END MATERIAL	<input type="text"/> SERIAL NUMBER	<input type="text"/> MO.-YEAR
<input type="text"/> PUMP TYPE	<input type="text"/> SEAL TYPE	<input type="text"/> ASSEMBLER	<input type="text"/> MAX TEMP. F.
		 DNV NO. D-2652	



**Declaration of Incorporation (Machinery)  
EC Declaration of Conformity (ATEX)**

**MANUFACTURER:**

National Oilwell  
10000 Richmond  
Houston, Texas 77006

**PRODUCT DESCRIPTION:**

Mission Magnum I Centrifugal Pumps

**APPLICABLE EUROPEAN DIRECTIVES:**

Machinery: 98/37/EC  
ATEX: 94/9/EC  
PED 97/23/EC

**APPLICABLE INTERNATIONAL STANDARDS:**

Machinery: EN 12100-1, EN 12100-2  
ATEX: EN 1127-1, EN 13463-1, EN 13463-5  
PED Not Applicable

**NOTIFIED BODY**

Det Norske Veritas, ATEX NB 0575 retains a copy of the Technical File

ATEX product marking:   II 2G c T5

TCF No: ATEX 0001

The equipment described in this Declaration of Incorporation complies with the Applicable European Directives and relevant sections of the Applicable International Standards. Integration instructions are provided that contain requirements and specifications that must be implemented prior to putting this equipment into service; this equipment must not be put into service before the machinery into which it is to be incorporated has been declared in conformity with the provisions of the Machinery Directive. The EHSR's related to this equipment have been addressed; a Technical Construction File is available for inspection by designated bodies.

Authorized Signature: \_\_\_\_\_

Date: March 24, 2005



Important safety information is contained in the installation, operation and service manuals; read and understand this information prior to installing or using this equipment

## Table of Contents...

### INSTALLATION

	<u>PAGE</u>
<b>I. GENERAL</b>	
A. Interchangeability.....	10
B. Location .....	10
C. Foundation.....	10
D. Coupling Alignment.....	11
E. Piping	
1. General.....	12
2. Suction.....	12
3. Discharge.....	12

### PREPARTION FOR OPERATION

<b>I. GENERAL</b>	
A. Initial Lubrication (Oil lubricated pumps).....	13
B. Mechanical Seals.....	13
C. Start Up .....	13

### OPERATION

<b>I. GENERAL</b>	
A. Priming.....	14
B. Maximum Operating Conditions.....	14
C. Pump Records.....	15
D. Pump Speed Limitations.....	15
E. Lubrication	
1. Bearings.....	16
2. Stuffing Box.....	16
3. Lip Seals .....	17

**Table of Contents...**

**MAINTENANCE**

	<u>PAGE</u>
<b>I. GENERAL</b> .....	17
<b>II. DISASSEMBLY</b>	
A. General.....	17-18
<b>III. INSPECTION</b>	
A. Impeller.....	19
B. Shaft.....	19
C. Shaft Sleeve.....	19
D. Mechanical Seal.....	19
E. Ball Bearings.....	19
F. Seals.....	19
G. General.....	19
<b>IV. ASSEMBLY</b>	
A. General.....	20
B. Shaft and Bearing Sub-Assembly.....	20
C. Power Frame Sub-Assembly.....	21
D. Assembly of Fluid End to Power Frame.....	22
E. Packing the Pump.....	22
F. Mechanical Seal.....	23-24
G. Assembly Figures 5 thru 9.....	25-29



## Table of Contents...

## TROUBLE SHOOTING PROCEDURES

PAGE

### I. GENERAL

A. Excessive Packing Leakage and Rapid Packing Wearout; Shaft Sleeve Coating Worn	30
B. Packing Burned.....	30
C. Excessive Stuffing Box Pressure.....	30
D. Trouble Shooting Guide.....	31

## MOUNTING DIMENSIONS

I. PUMP DIMENSIONS.....	32
II. PUMP and FABRICATED BASE.....	33
III. PUMP and CHANNEL BASE.....	34
IV. PUMP and SKID BASE.....	35
V. 2½ SHAFT MAGNUM PUMPS WITH FABRICATED BASES FOR T FRAME MOTORS ..	36
VI. DUTY MASTER ALTERNATING CURRENT MOTORS.....	37

## ENGINEERING DATA

I. SUCTION PIPING .....	39-43
-------------------------	-------

## Installation...

### I. GENERAL

#### A. INTERCHANGEABILITY

Interchangeability between Magnum I horizontal centrifugal pumps and older W pumps will permit pumps of the same nominal size to be interchanged using existing piping and bases.

#### B. LOCATION

The pump should be located near the liquid source so that the suction line may be short and direct. The pump should be located below the level of the liquid to eliminate the necessity of priming.

#### C. FOUNDATION

The foundation should be sufficiently rigid and substantial to absorb any vibration and to permanently support the base plate at all points. A concrete foundation, poured on a solid footing of adequate thickness to support the pumping unit, provides the most satisfactory foundation. The base plate should be installed in a level position. Figure 1 shows a typical arrangement for bolting channel bases.

The rugged design of the frame and the fluid end makes the Magnum I more tolerant of improper foundations than many other pumps. When fabricated skid bases are utilized, the foundation should be sufficiently rigid and leveled properly to absorb any vibration and to permanently support the base at all points.

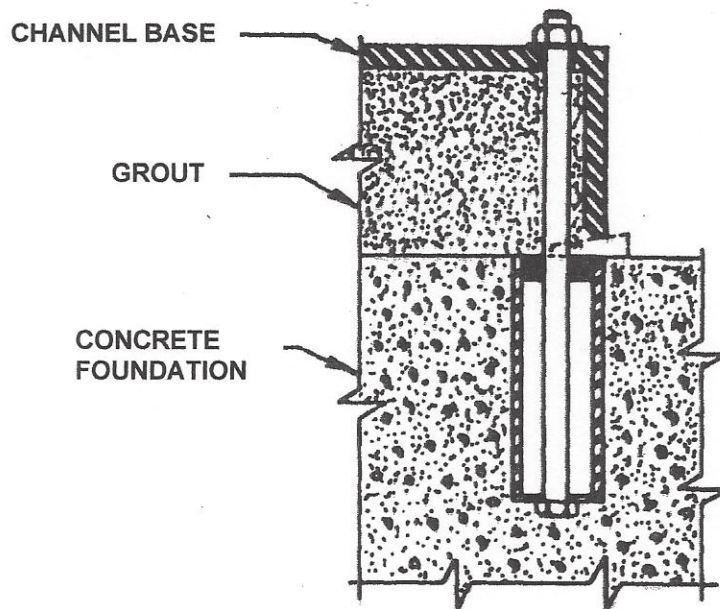

Figure 1

NOTE: A detailed description of proper Procedures for grouting base plates may be found in the Hydraulic Institute Standards, 13<sup>th</sup> Edition, Pages 116 and 117.

## Installation...

### I. GENERAL (Continued)...

#### D. COUPLING ALIGNMENT

Good service life of the pump and driver depends upon good alignment through the flexible coupling. If the electric motor was mounted at the factory, the pump and motor were in alignment when shipped. **The alignment between the driver and pump should be inspected after installation to ensure that transportation or other handling has not caused misalignment of the unit.** Poor alignment may cause failure of the coupling, pump, or motor bearings, or of either shaft.

**Alignment must not be attempted until the base is in position and the mounting and flange bolts have been tightened.**

The recommended procedure for coupling adjustment is by the use of a dial indicator, as illustrated in Figures 2 and 3. The dial indicator is attached to one coupling half with the indicator button resting on the O.D. of the other coupling half to measure offset misalignment. To measure angular misalignment, the indicator is positioned so that the button rests on the face, near the O.D., of the other coupling half. Rotate the shaft and dial indicator one full revolution while the other shaft remains stationary and note the T.I.R. Unless otherwise specified by the coupling manufacturer, offset misalignment should be limited to 0.010 inches T.I.R. and angular misalignment should be limited to 0.005 inches T.I.R. Adjust misalignment by loosening driver or pump mounting bolts and re-tightening or shimming as required.

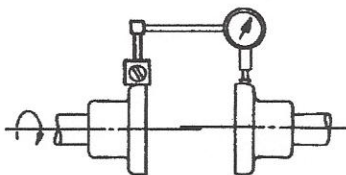

**Figure 2 – Measuring Offset Alignment**

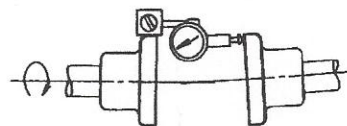

**Figure 3 – Measuring Angular Alignment**

In areas where a dial indicator arrangement is not available, an adequate job of alignment can be done with a straight edge. This method is especially useful if the coupling used contains an all rubber drive element.

To check offset misalignment, lay the straight edge in line with the shafts on the O.D.'s of the coupling halves. There should be no gaps under the straight edge. Check two locations 90° apart. Angular misalignment can be checked by measuring the gap between coupling half faces. There should be no more than 1/64" gap under the straight edge or 1/64" variation in the gap between coupling halves. See Figures 2A and 3A.

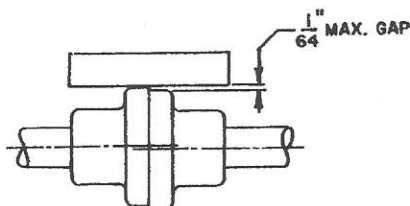

**Figure 2A**

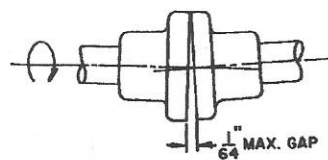

**Figure 3A**

**NOTE:** Further reference on coupling alignment can be found in Hydraulic Institute, 13<sup>th</sup> Edition, Pages 117 and 120.

## Installation...

### I. GENERAL (Continued)...

#### E. PIPING

##### 1. General

NOTE: Piping must not be connected to the pump until the grout has hardened and foundation bolts and pump holddown bolts have been tightened.

Piping should be anchored independently of the pump and as near to it as possible. Pipe companion flanges should line up naturally with pump flanges. **Do not draw the pipe to the pump with flange bolts.**

##### 2. Suction

Properly selected and installed suction piping is extremely important to eliminate vibration and cavitation in the pump. Vibration can cause packing problems, mechanical seal damage or undue bearing loads. The suction line should be equal to or larger than the pump suction.

**The capacity of a centrifugal pump should never be adjusted by throttling the suction line.** A positive shut-off valve of a type to cause minimum turbulence should be installed in the suction line to permit the closing of the line and removal of the pump for inspection and maintenance.

The suction line should be designed to eliminate any air pockets. The piping should gradually slope downwards to the source of supply to eliminate air pockets.

The suction line should have a straight section into the pump of a length equivalent to at least two (2) times its diameter; i.e., 4-inch suction; 8-inch straight run.

For temporary hook-up, where flexible hose is used, a non-collapsing hose is essential since the suction line pressure is often below atmospheric pressure. A collapsing suction line will result in below average or complete loss of flow. (See "Engineering Data" in this manual for illustrations.)

##### 3. Discharge

A positive shut-off valve should be located in the discharge piping to permit inspection and maintenance of the pump.

All piping should be independently supported and accurately aligned. **The pump must not support the weight of the pipe or compensate for misalignment.**

If operating conditions are not known with sufficient accuracy, it will be necessary to provide a throttle valve in the discharge line to ensure that the pump operates at the design point.

If the pump is connected to a pressurized system, it is important to install a check valve between the pump discharge and the throttling valve. The check valve will prevent back flow through the pump. Back flow may cause the impeller to become loose on the shaft. A loose impeller will likely result in mechanical damage and fluid leakage beneath the shaft sleeve.

## Preparation for Operation...

### I. GENERAL

#### A. INITIAL LUBRICATION (OIL LUBRICATED PUMP)

NOTE: Oilers are set at the factory to the lowest position. This setting will place the oil level just below the center of the bottom ball of the bearing when the housing is level. Higher levels may cause churning and overheating of the bearings; lower levels may provide insufficient lubrication and promote rapid wear. **The correct oil level will be visible at the center of the sight oil gauge.**

Standard pumps are shipped with empty oil reservoirs. **Oil must be added before operating the pump.** Attach the oiler to the bearing housing, fill the bottle with oil and place it in position. Refill the bottle until the bottle remains full of oil. Oil should not be added to the reservoir except through the oiler bottle.

A good grade of SAE 10W 30 oil may be used.

The air vent should be kept clean to prevent pressure build-up because of normal heating that occurs in operation. A Trico Optomatic Oiler No. EB-64 with a 4 ounce capacity bottle is used. **The correct bottle must be used with the corresponding oiler body.**

#### B. MECHANICAL SEALS

When mechanical seals are furnished, the description and identification is indicated on the order write-ups, which are a part of the order acknowledgment, dimension print and the packing list. The seals are installed and adjusted at the factory. To properly prepare the seal for operation, various cooling and flushing flows may have to be connected. Liquid from an outside source may be required. Connect necessary cooling and flushing flows to mechanical seal, be sure flow is turned on before starting the pump.

 **! WARNING ! WARNING ! WARNING !** 

NEVER OPERATE A PUMP "DRY" WITH MECHANICAL SEALS. MECHANICAL SEAL FAILURE WILL OCCUR!

#### C. START-UP

 **! WARNING ! WARNING ! WARNING !** 

IT IS ABSOLUTELY ESSENTIAL THAT THE ROTATION OF THE MOTOR BE CHECKED BEFORE CONNECTING THE SHAFT COUPLING. INCORRECT ROTATION OF THE PUMP FOR EVEN A SHORT TIME WILL DISLodge THE IMPELLER AND DAMAGE THE IMPELLER, SHAFT OR BEARING HOUSING. THE PUMP SHAFT MUST TURN CLOCKWISE WHEN VIEWED FROM THE MOTOR END.

Check the following items before starting the pump:

1. Pump rotates freely by hand
2. Coupling aligned
3. Oiler full and oil level correct
4. Suction valve fully open
5. Pump and suction line full of fluid
6. Water to stuffing box or gland flush
7. Discharge valve slightly open

## Operation...

### I. GENERAL

#### A. PRIMING

Vent air from suction line and fill with liquid. Start pump with discharge valve cracked open. After discharge pressure stabilizes, gradually open discharge valve to required position. If flow is lost, close discharge valve and wait a few seconds for discharge pressure to build.

Continued flow difficulty indicates an improper selection or installation. Running the pump too long with improper prime may destroy the sealing faces of the mechanical seal due to mechanical damage from pulsation and interference between rotating and stationary components.

Thermal shock may crack the ceramic stationary seat if temperature is raised from room temperature to 250°F in less than 30 seconds.

**Do not run pump** with suction and discharge valves closed.

#### B. MAXIMUM OPERATING CONDITIONS

NOTE: These maximum operating conditions apply to pumps which are exposed to room temperatures without external insulation.

1. Cast Iron: Maximum working pressure 175 psig at 150°F for 150 psig at 250°F. Interpolate for pressure between 150° and 250°F maximum.
2. Steel: Maximum working pressure and test pressure in accordance with Tables 2.1 through 2.23 and Table 3, ANSI B 16.5-1973.
3. For H-30 and Magchrome Alloy: contact Mission Distributor.
4. Cooling water through the lantern ring is required when the fluid being pumped is between 150°F and 250°F. In addition, it may be necessary to run water over the exposed shaft to prevent excessive heat at lip seals and bearings.
5. Maximum hydraulic performance in accordance with published performance curves for individual pump sizes.

## Operation...

### C. PUMP RECORDS

Maintain data cards or pump records whenever possible. *This will provide ready access to information for ordering spare parts and for evaluating pump and mechanical seal performance.*

Information to be included in these records should be:

1. Pump size and serial number.
2. Pump model number, impeller diameter, material of construction.
3. Mechanical seal manufacturer, type, code and drawing number.
4. Motor horsepower and speed of operation.
5. Service conditions.
6. Frequency of operation.
7. Record of maintenance, including parts usage and general condition of the pump.
8. Nomenclature and part number of replacement items.

### D. PUMP SPEED LIMITATIONS

Pump Speed Limitations	
Bearing Lubricant	Max. RPM Allowable
Grease	2400
Oil Bath	3500

With the large shaft and bearings used in this pump, the above limitations must be observed in order to control bearing operating temperature.

## Operation...

### E. LUBRICATION

#### 1. Bearings

##### a. Grease

Bearings are prelubricated from the factory. Grease lubricated and oil lubricated centrifugal pumps should be included in the customer's lubrication maintenance program. It is recommended that grease lubricated pumps have five shots from a standard hand operated grease gun injected into the inboard and outboard bearing lubrication ports every three (3) months. The shaft should be rotated 1/4 turn between each shot of grease. Mystic JT-6 Hi-Temp No. 2 is used during assembly at the factory. It is important that the same or a compatible NLGI No. 2 certified for GC-LB high temperature grease be utilized. Grease available in sealed tubes is recommended. If grease from other type containers is used, ensure the grease is clean and free from water or other contamination. The inboard bearing cap is equipped with an inlet and relief grease port. The relief port should be removed and grease should be added to the inlet port until grease exits the relief port. Be sure to replace the relief plug after lubrication.

##### b. Oil

Pumps are shipped less oil. Oil lubricated pumps must be maintained and operated in a horizontal level position. The pump is equipped with a dip stick to allow the operators to check the oil level. Oil lubricated pumps should be inspected on a daily basis to ensure proper oil levels are maintained. The oil should be changed on a quarterly basis or if contamination has occurred. The recommended oil is 10W30 non-detergent. Synthetic oils are not recommended due to their incompatibility with standard oils.

#### 2. Stuffing Box

The stuffing box may be relubricated as often as necessary to prevent the packing from overheating. It should be lubricated at least once a day.

Grease should be pumped into the box while turning the shaft until it comes out around the packing gland (approximately 20 shots).

If the packing leakage is excessive, a thick water compatible pump grease should be used rather than the general purpose grease. In most cases, general purpose grease will be acceptable.

Front View of  
Inboard Bearing Cover  
Figure 4

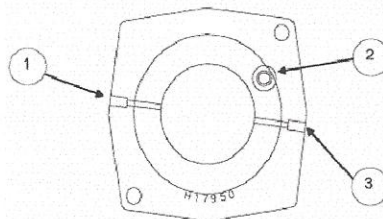

#### Inboard Bearing Cover

1. Oil seal inlet grease port
2. Bearing grease port
3. Oil seal relief port



## Operation...

### E. LUBRICATION (Continued)...

#### 3. Lip Seals

The inboard bearing cover is supplied with a zerk fitting between the 10 and 11 o'clock position facing the suction. This is designed to create a grease barrier between the inboard lip seals and should be greased prior to washdown and at least once a week with 5 shots of general purpose or water pump grease. (See Fig. 4, Pg. 12.)

## Maintenance...

### I. GENERAL

Refer to Cross Section Drawing and Parts List for materials and location, Fig. 5, Pg. 21, Fig. 6, Pg. 22, and Fig. 9, Pg. 25.

### II. DISASSEMBLY

#### A. GENERAL

1. Loosen packing gland nuts (6B) and swing gland bolts to side. Remove packing gland halves (4).
2. Remove casing bolt nuts (1B).
3. Remove casing (1).
4. Restrain the shaft (7) at the coupling end to prevent rotation while removing the impeller. NOTE: Mission Impeller Removal Wrench Part No. 20952 is very useful.

Put a block of wood or pipe, etc. against web between impeller vanes. Hit wooden block with sledge to **turn impeller counterclockwise as viewed from suction end**. If Mission Impeller Wrench is used, the wrench can be impacted against a solid surface using the impeller's own weight to jar it loose.

5. Remove stuffing box cover bolt (3A).
6. Remove stuffing box cover (3) from frame by hammering on the back side in the area where the box fits into the frame (9).

**NOTE: If the disassembly being performed does not require the replacement of the mechanical seal, the stationary seat (Item 1 on Figure 9) must not be removed from the stuffing box.**

7. Pull packing (5) from stuffing box bore.

## **Maintenance...**

### **II. DISASSEMBLY**

#### **A. GENERAL (Continued)...**

8. Remove shaft sleeve (7A). A wedge may be driven between the end of the sleeve and shoulder on shaft to free the sleeve. If the pump has a mechanical seal that does not need to be replaced, care must be taken to avoid damaging or dropping the rotary seal ring (Item 4A on Figure 9, Pg. 25) when removing the sleeve.

**NOTE: If the disassembly is being performed to replace or install a mechanical seal and/or shaft sleeve only, no further disassembly is required. See mechanical seal installation instructions in "Maintenance, Assembly, F. Mechanical Seal Assembly Instructions" in this manual.**

9. Remove the deflector (8).
10. Remove plug (10A) from inboard bearing cover (10).
11. Remove the two through bolts (12B) on the outboard bearing housing (12). **These are the bolts threaded into the frame (9).**
12. The complete shaft and bearing subassembly can now be pulled from the frame.
13. Remove outboard bearing cover (13).
14. Bend tab on lockwasher (14A) back and remove locknut (14B) and lockwasher.
15. Remove bearing housing (12) and bearings (14) from shaft.

**NOTE: Impacting of entire shaft assembly against a board on the ground will remove the outboard bearing assembly.**

16. Inboard bearing (11) may now be pressed off shaft.

**NOTE: A piece of 3" standard wall pipe slipped over shaft and impacted against the inner race of the bearing works exceptionally well.**

## **Maintenance (Continued)...**

### **III. INSPECTION**

#### **A. IMPELLER**

Replace if impeller shows excessive erosion (especially on pump-out vanes on back side of impeller), corrosion, extreme wear or vane breakage.

#### **B. SHAFT**

Check for runout to see that shaft has not been bent. If runout exceeds 0.002", replace shaft. Bearing seats and oil seal area must be smooth and free of scratches or grooves. Shaft threads must be in good condition. Replace shaft if necessary.

#### **C. SHAFT SLEEVE**

Sleeve surface in stuffing box must be smooth and free of grooves. If grooved, replace.

#### **D. MECHANICAL SEAL**

Seal faces, gaskets and shaft sealing members must be in perfect condition or excessive leakage may result. Replace worn or damaged parts.

#### **E. BALL BEARINGS**

Replace if worn, loose or rough and noisy when rotated. New bearings should not be unwrapped until ready for use. Replacement bearings must be of the proper size and type as supplied with original equipment.

#### **F. SEALS**

It is recommended that all O-Ring and gasket seals removed during disassembly be replaced. In those cases where new seals are not available, the old ones can be reused if they are not torn or otherwise damaged.

#### **G. GENERAL**

All parts should be clean before assembly. This is especially important at retaining ring and O-Ring grooves, threads, gasket surfaces and bearings and bearing lubricated areas. Any burrs should be removed with crocus cloth.

## **Maintenance (Continued)...**

### **IV. ASSEMBLY**

#### **A. GENERAL**

Numbers following part name refer to the part as shown on the cross-sectional drawing (Fig. 5, Pg. 21).

#### **B. SHAFT and BEARING SUBASSEMBLY**

**NOTE:** Installation of the bearings with a press is an acceptable substitute for the following method. **Apply load to the inner race only, when pressing the bearings onto the shaft.**

1. Heat bearings to 300°F.

**NOTE:** One-half hour in an oven at 300°F will work nicely.

2. Slip large, inboard bearing (11) onto the shaft.

**CAUTION: Bearings must shoulder against the shaft.**

3. With bearing housing seal (12A) in place, slide the bearing housing (12) onto the shaft from the coupling end. The large O.D. of the bearing housing should be facing the coupling end.

4. Slip outboard bearings (14) onto the shaft.

**NOTE:** Bearings are to be mounted back to back, that is, the sides of the bearings with manufacturers name and the bearing number are placed together.

**CAUTION: Bearings must shoulder against the shaft.** Allow bearings to cool. With lockwasher (14A) in place, tighten locknut (14B) with the bevel positioned against the bearings. **Tighten locknut to 250 ft/lb torque. Bend tab of lockwasher into nut.**

5. Pack the bearings (14 and 11) full with grease, preferably Chevron SRI-2 or any of the aforementioned greases.
6. Lightly grease or oil outboard bearing (14) O.D.'s and pull bearing housing over them into place. The outer races may be pushed in with a hand push or with light tapping **applied only to the outer race.**
7. Install lip seal (13C) in outboard bearing cover (13) with the lip aimed inward toward the bearings. Generously lubricate the rubber lip and the shaft in the sealing area. Fill the space behind the lip on the seal and half the bearing cover with grease.
8. Put cover seal O-Ring (13B) in place. Slide the outboard bearing cover over the shaft. **CAUTION: be careful not to cut the oil seal on the edge of the shaft keyway.** Secure cover with two (13D) bolts (3/8<sub>D</sub> X 1 1/4") and (13E) washers tightened evenly to approximately 20 ft/lb torque.

## Maintenance...

### IV. ASSEMBLY (Continued)...

#### C. POWER FRAME SUB-ASSEMBLY

1. Install inboard bearing cover seal (10C) into inboard bearing cover (10) flush with the backside of the cover. Install the exclusion seal (10F) flush with the outside of the cover. **The sealing lips on both seals should be pointed outward (away) from the bearings for grease lubrication, the lip of inboard bearing cover (10C) points inward for oil lubrication.** Pack the area between the lip seals full with grease. Using grease to hold it in place, put the inboard bearing cover gasket (10B) on the cover.
2. Insert the shaft and bearing subassembly into the frame (9) until the threaded end of the shaft extends approximately halfway into the drip pan area.
3. Slip inboard bearing cover assembly (10) over the end of the shaft. Continue installing the shaft and bearing assembly in the frame until the gap between the frame and bearing housing flange is approximately 1/4".
4. Install two (12B) bolts (1/2<sub>D</sub> x 1 1/2") with jam nuts (12C) in the threaded holes in the bearing housing. Install the remaining two (12B) bolts through the unthreaded holes in the bearing housing and thread them into the frame. **Do not tighten any bolts.**
5. Bolt inboard cover to frame with (10D) bolts (3/8<sub>D</sub> x 2") and (10E) nuts.
6. Lubricate deflector O-Ring (8A) and install in deflector (8). Slip deflector assembly on shaft with ribbed side facing away from the bearing cover.
7. Slip shaft sleeve seal (7C) onto the shaft and push it to the shoulder where the sleeve will seat. For pumps with a mechanical seal, see mechanical seal installation instructions in "Assembly" for assembling the remainder of the pump.
8. **The sleeved area of the shaft must be lightly coated with an anti-seize compound before installing the sleeve.** Install sleeve (7A) with a twisting motion to spread anti-seize compound. The gap between the sleeve and the shaft shoulder will be approximately 1/32".

## Maintenance...

### IV. ASSEMBLY (Continued)...

#### D. ASSEMBLY OF FLUID END TO POWER FRAME

1. Lubricate the inside of the frame where the stuffing box cover slips in with an anti-seize compound. Install stuffing box cover (3) and secure with bolt (3A).
2. Lubricate shaft threads and face of shaft sleeve with anti-seize compound. Wash off the O-Ring with clean shop solvent and pat dry with a clean cloth. Install the O-Ring into the impeller. **DO NOT USE ANY LUBRICANTS.** Thread the impeller (2) with impeller seal O-Ring (2A) onto the shaft. Tighten to approximately 160 ft/lb torque.
3. Loosen the two through bolts (12B).
4. Draw the bearing housing rearward with the jam bolts (12B) while rotating the impeller. Stop when the impeller just touches the stuffing box cover.
5. Bring the through bolts up finger tight.
6. Loosen the jam bolts.
7. Tighten the through bolts (12B) until a clearance of .020" exists between the impeller (2) back vanes and stuffing box cover (3). A hack saw blade is about .020" thick and can be used as a gauge when no better tooling is available.
8. Advance both jam bolts (12B) until they touch the frame finger tight, then tighten the jam nuts (12C).
9. Now tighten the through bolts down evenly. Rotate the shaft. **The impeller should turn freely without rubbing.**
10. Install casing gasket (1A). Hold it in place with grease if necessary.
11. Apply a light coat of anti-seize compound on the stuffing box cover.
12. Install casing (1) on the frame using studs (1C) and nuts (1B). Put a small quantity of anti-seize lubricant on the threads on the nut end of the studs. Tighten nuts to 140 ft/lb torque using a crisscross tightening pattern.

#### E. PACKING THE PUMP

Grease all five shaft packing rings (5). Insert three packing rings alternating the splits in the rings from top to bottom starting with the split on the first ring at the bottom. If King type packing is being used, the rings should be installed with lips toward the impeller.

Install the lantern ring with the split in the vertical position. The two halves of the packing gland (4) may be used to push packing and lantern ring together and to the bottom of the box.

Insert the final two packing rings. If King packing is being used, insert the final ring with the lip toward the outside and split on top and follow with the single ring of square packing.

With the packing gland (4) in position, swing gland bolts into place. Tighten the gland lightly against the packing using the gland bolt nuts. **CAUTION: tighten gland against packing finger tight only. If packing is over tightened it may be burned when the pump is started.**

## Maintenance...

### IV. ASSEMBLY (Continued)...

#### F. MECHANICAL SEAL

1. Tighten the two through bolts (12B) until the gap between the frame (9) outboard bearing housing (12) is about 1/16".
2. Make sure that the inside of the stuffing box (3) is clean and that the 30° bevel on the 3 $\frac{3}{8}$ " I.D. is free burrs and sharp edges. Coat the I.D. of the stuffing box stationary seat pocket with oil. Place the stuffing box on a table or other flat surface with the impeller side facing up.
3. Remove the sticker from stationary seat (Item 1, Figure 9) if one is attached. The sticker side or slotted side must be installed away from the impeller or down when the stuffing box is positioned as described in step No. 2 above. Coat the O.D. of the stationary seat and O-Ring (Items 1 and 1A, Figure 9) with a thin film of oil.
4. Carefully install the stationary seat (Item 1, Figure 9) into the stuffing box. **Be sure groove of stationary fits properly over drive pin.** (See Figure 9, Items 1 and 15.) Be sure that the stationary seats evenly against the stuffing box shoulder. (See cross section drawing.)

**HINT:** Wrap the end of a wooden hammer handle with a rag and press firmly on the face of the stationary. **Do not strike.** Push gently on a side alternating from side to side until the stationary seat is all the way down.

Coat the stationary seat (Item 1, Figure 9) face with light oil, then wipe off the majority of the oil with a clean cloth leaving only a light film.

5. Lubricate the inside of the frame (9) where the stuffing box (3) slips in with an anti-seize compound. Install the stuffing box and secure with bolt (3A). Care should be taken to prevent bumping the stationary seat (Item 1, Figure 9) on the shaft end.
6. Remove the rotating seal ring (Item 4A, Figure 9) if it is not glued in position and stored in a safe place. Whether or not it is glued can be determined by pulling on it gently. Coat the O.D. of the shaft sleeve (7A) and the I.D. of the bellows (Item 4B, Figure 9) with a thin coat of oil.
7. Place the sleeve (7A) with impeller end up on a table. The impeller end is the end with the smallest I.D. With the sealing face of the rotary unit facing down and the rubber end up, gently ease the rubber bellows over the sleeve and push it to the bottom half of the sleeve. (Not necessary to push all the way to the bottom.) If the rotating seal ring (4A) has been removed, lightly coat the face of the bellows (Item 4B, Figure 9) with grease. (This is necessary to hold the rotating seal ring in place during assembly.) Reinstall the rotating seal ring into the cage assembly (Item 4C, Figure 9) if it has been removed.
8. Make sure no foreign material is on the seal faces. Make sure the shaft (7) is free of nicks and burns and is clean and dry. The sleeve area of the shaft, the shaft threads and shaft face must be lightly coated with an anti-seize compound before installing the sleeve (7A). Install sleeve with a twisting motion. As the seal faces make contact continue to push the sleeve through the I.D. of the rotary seal element until the gap between the sleeve and the shaft shoulder is approximately 1/32".

**CAUTION:**

**Older pumps will have a drive pin. It must be engaged in the groove provided in the sleeve I.D.**

## Maintenance...

### IV. ASSEMBLY

#### F. MECHANICAL SEAL (Continued)...

9. Install the spring retainer (Item 9, Figure 9) and the impeller O-Ring (2A) in its groove and coat with anti-seize compound. Place the mechanical seal spring (Item 6, Figure 9) over rotary unit of the seal which is inside the back cover.
10. Thread the impeller (2) onto the shaft (7). Be sure that the spring engages in the retainer on the impeller. Tighten to approximately 160 ft/lb torque.
11. Back the through bolts (12B) out approximately 1/4". Tighten the jam bolts (12B) until a clearance of 0.015" – 0.020" between the back of the impeller (2) and stuffing box (3) is obtained. **Do not move the impeller (2) toward the stuffing box and then back out.** This will cause improper compression of the seal bellows. **If the impeller is moved out by mistake, the entire seal rotary unit must be removed and reinstalled on the sleeve.** Alternately tighten the through bolts and jam bolts making sure that the clearance set above is maintained. Tighten the jam nuts and recheck the clearance.
12. Install casing gasket (1A). Hold it in place with grease if necessary. Apply a light coat of anti-seize compound on the 14 1/8" diameter of the stuffing box cover. Install casing (1) on the frame using studs (1C) and nuts (1B). Put a small quantity of anti-seize lubricant on the threads on the nut end of the studs. Tighten nuts to 140 ft/lb torque using a crisscross tightening pattern.
13. Grease all three shaft packing rings (5). Insert all packing rings alternating the splits from top to bottom starting with the split on the first ring at the bottom.
14. Attach gland bolts (6) to pump with nuts (6A). Start the gland bolt nuts. With the packing gland (4) in position, swing the gland bolts into place. Tighten gland bolt nuts lightly against the packing.

**CAUTION: Tighten gland against packing finger tight only. Packing will be used only if the mechanical seal fails.**

15. Flushing arrangement for seals are shipped with the pump. Instructions are also included.



**Maintenance...**

**IV. ASSEMBLY**

**G. ASSEMBLY FIGURES 5 THRU 9**

See Figure 6 for part descriptions.

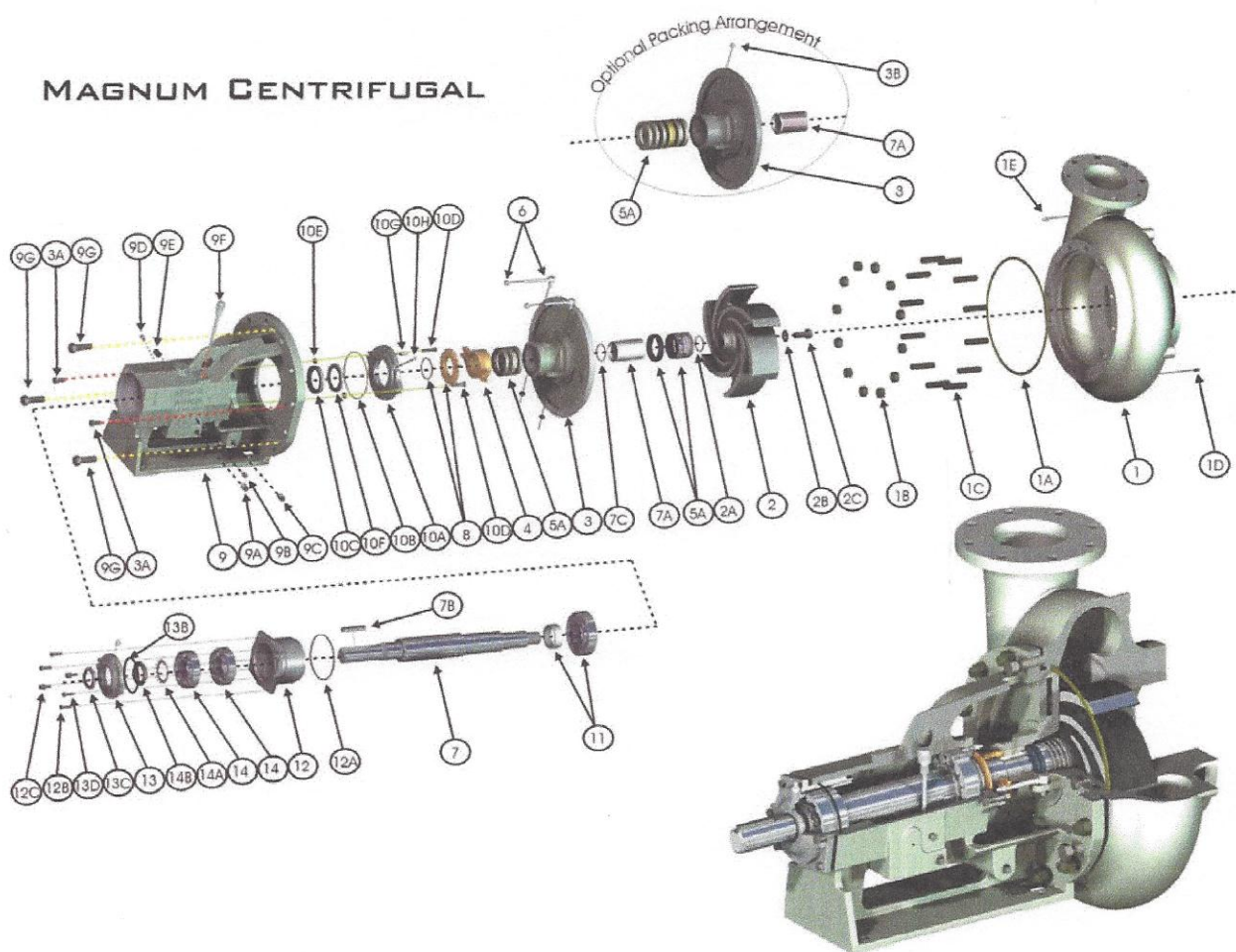

Figure 5

## Maintenance...

### IV. ASSEMBLY

#### G. ASSEMBLY FIGURES 5 THRU 9(Continued)...

Magnum Parts List											
Item	Qty	Part Number	Process #	Description	Material	Item	Qty	Part Number	Process #	Description	Material
1*	1	See Below	See Below	Casing	Hard Iron	10E	2	3932-2	601408560	Nut, I.B. Brg. Cover	Stl
1A	1	10399-46-1	648403012	Gasket, Casing	Vellumoid	10F	1	20620-01	648408409	Exclusion Seal, I.B. Brg. Cvr.	Buna-n
1B	12	3932-61	648402014	Nut, Casing	Stl	10G	1	21641-01	661010033	Grease Fitting	Stl
1C	12	3862-76	648401115	Stud, Casing	Stl	10H	1		648411908	Grease Fitting	Stl
1D	1	8505-04-01	86485503	Plug, Casing Drain	Stl	11	1	N/A	661009010	Bearing, Inboard	Vendor
1E	1	8505-04-01	646400507	Plug, Flush Line	Iron	12	1	20624-01-01	644308504	Housing, O.B. Bearing	Iron
2*	1	See Below	See Below	Impeller	Hard Iron	12A	1	7496-253	648402295	Seal, O.B. Brg Housing	Buna-n
2A	1	19110-72	648405082	Seal, Impeller	Viton	12B	4	3861-138	648401057	Bolts, O.B. Brg. Housing	Stl
2B	1		7300239	Washer, Impeller	Stl	12C	2	3932-62	658404702	Nut, O.B. Brg. Housing Jam	Stl
2C	1		7415648	Bolt, Impeller Lock	Stl	13	1	20617-01-01	641103296	Cover, O.B. Bearing	Iron
3*#	1	22223-01-30	641116157	Stuffing Box, Mech. Seal	Hard Iron	13A	1		661010020	Grease Zerk, O.B. Brg. Cvr.	Stl
3&	1	20614-01-30	643365042	Stuffing Box, Packed	Hard Iron	13B	1	7496-26	072200017	O-ring, O.B. Bearing Cover	Buna-n
3A	2	3861-117	648401018	Bolt, Stuffing Box	Stl	13C	1	20619-02	648408359	Oil Seal, O.B. Brg. Cover	Buna-n
3B&	1	19368-01	601499403	Grease Fitting	Stl	13D	2	3861-139	648401081	Bolt, O.B. Brg. Cover	Stl
4	1	20622A	641103338	Gland Assy., Packing	Bronze	14	1	N/A	648408201S	Bearing, O.B. (2 Req'd)	Vendor
5A#	1	22451-1	648414308	Seal, Mechanical	Tungsten Carbide	14A	1	6124-4	648402105	Lockwasher, O.B. Bearing	Stl
5A-	1	25014-04M-B	661007005	Packing, Shaft	Graphite/Acrylic	14B	1	6123-4	648402055	Locknut, O.B. Bearing	Stl
6	2	B3701A	601102494	Bolt Assy, Gland	Stl	<b>Casings - Includes Studs, Nuts &amp; Gasket</b>					
7	1	20612-02-33	646490557	Shaft	AISI 4140	1*	1	19203-01-30A	641101753	Casing, 3x2x13	Hard Iron
7A#	1	20943-21	641102182	Sleeve, Shaft (M.S. Pump)	416SS	1*	1	19205-01-30A	641101902	Casing, 4x3x13	Hard Iron
7A&	1	20613-21G-7A	641102181	Sleeve, Shaft (Pack Pump)	416SS/Ceramic	1*	1	19222-01-30A	641102058	Casing, 5x4x14	Hard Iron
7B	1	4372-5-21	601212392	Key, Shaft	416SS	1*	1	19122-01-30A	641101456	Casing, 6x5x11	Hard Iron
7C	1	23444-01-72	648415156	Seal, Shaft Sleeve	Viton	1*	1	19123-01-30A	641101605	Casing, 6x5x14	Hard Iron
8	1	22210-1A	641116108	Deflector Assembly	Bronze	1*	1	19763-01-30A	641102157	Casing, 8x6x11	Hard Iron
9	1	20618-12-1	644302499	Frame, Grease Lubricated	Cast Iron	1*	1	19117-01-30A	641101308	Casing, 8x6x14	Hard Iron
9A!	1	8505-05	601474737	Plug, Oil Drain	Iron	1*	1	20937-01-30A	641102322	Casing, 10x8x14	Hard Iron
9B!	1	18471	648403608	Plug, Oil Fill	Iron	<b>Impellers</b>					
9C	1	8505-05	601474737	Plug, Frame Drain	Iron	2*	1	19204-XX-30	Varies	Impeller, 3x2x13	Hard Iron
9D	1	8267-01	601473689	Breather	Stl	2*	1	19206-XX-30	Varies	Impeller, 4x3x13	Hard Iron
9E	1	8478-3	601174584	Oiler Assembly		2*	1	19224-XX-30	Varies	Impeller, 5x4x14	Hard Iron
9F!	1	A 662014131	662014131	Dip Stick	Stl	2*	1	19121-XX-30	Varies	Impeller, 6x5x11	Hard Iron
9G	3	2538-1H		Bolt, Casing Jack	Stl	2*	1	19121-XX-30	Varies	Impeller, 6x5x14	Hard Iron
10A	1	20626	644303109	Cover, Inboard Bearing	Iron	2*	1	19121-XX-30	Varies	Impeller, 8x6x11	Hard Iron
10B	1	20625	648408706	Gasket, I.B. Brg. Cover	Vegetable Fiber	2*	1	19116-A0-30	Varies	Impeller, 8x6x14	Hard Iron
10C	1	20619-01	648408300	Oil Seal, I.B. Brg. Cover	Buna-n	2*	1	21867-XX-30	Varies	Impeller, 10x8x14	Hard Iron
10D	2	3861-1	601407505	Bolt, I.B. Brg. Cover	Stl						

XX - Impeller Code - First X equals diameter of impeller in inches minus 4. Therefore 10" = 6, 9" = 5, 8" = 4, etc... 14" use letter A.  
 Second X equals fractional data in 1/8's. Therefore 1/8" = 1, 1/4" = 2, 1/2" = 4, etc... Thus a 10.5" impeller is coded as 64, a 12" impeller is coded as 80, a 13.25" impeller is coded as 92 etc...

**Notes:**

\* - Casings, Impellers and Stuffing Boxes are also available as Stainless Steel, Aluminum Bronze or Magnachrome - See local dealer for Part Numbers.

# - Used for pumps equipped with mechanical seal only.

& - Used for pumps equipped with packing only.

! - Used for oil lubricated pumps only.

-- Packing available in various materials - standard material shown

Figure 6

**Maintenance...**

**IV. ASSEMBLY**

**G. ASSEMBLY FIGURES 5 THRU 9(Continued)...**

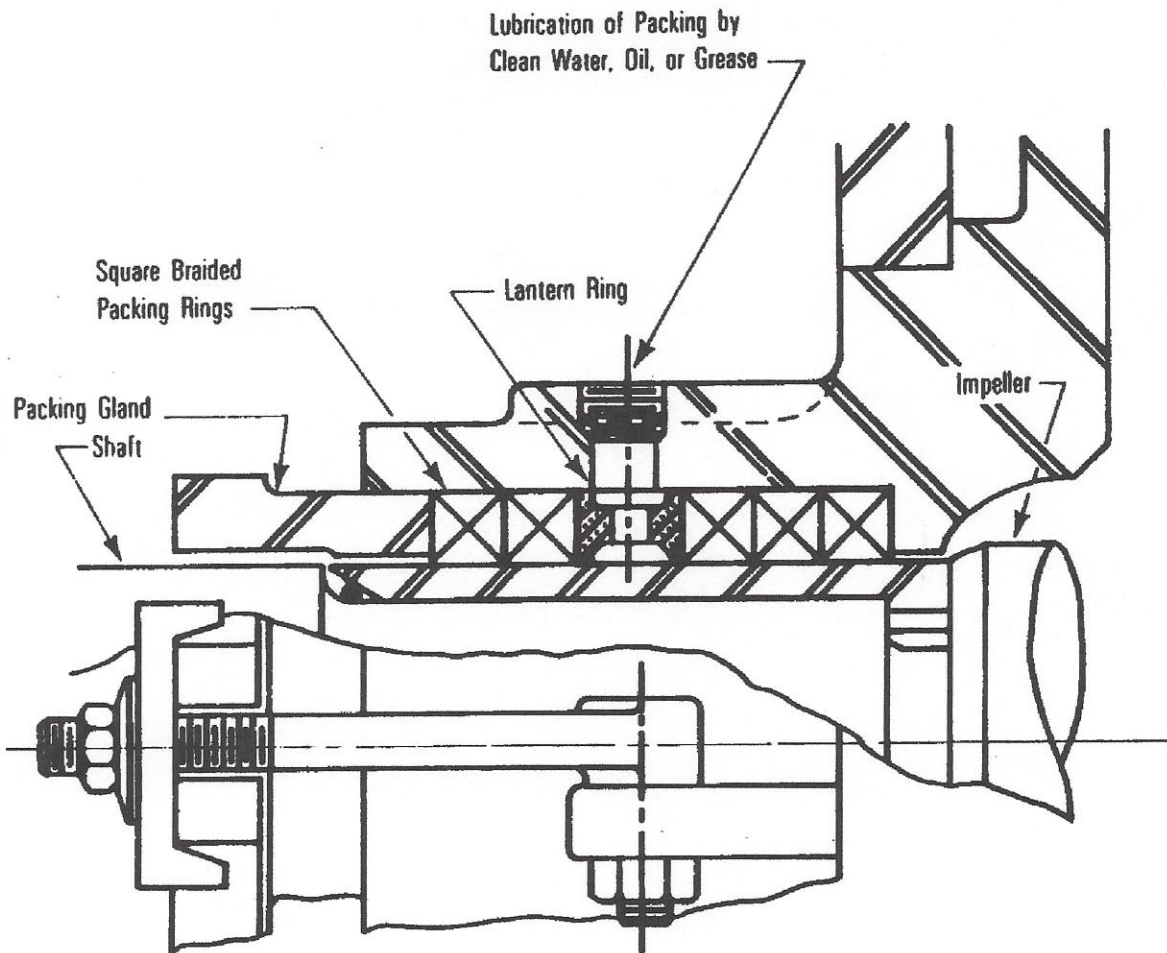
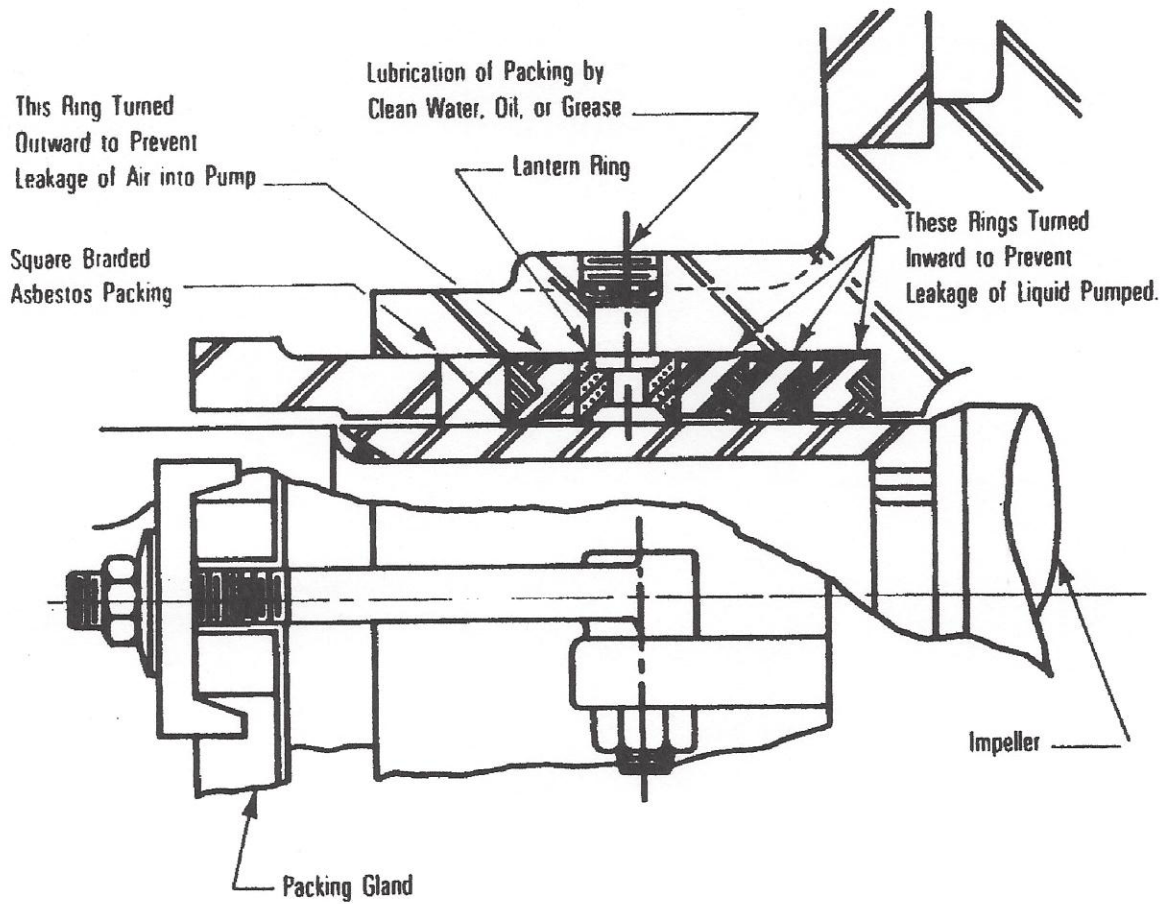

**Figure 7  
Braided Packing**

**Maintenance...**

**IV. ASSEMBLY**

**G. ASSEMBLY FIGURES 5 THRU 9(Continued)...**

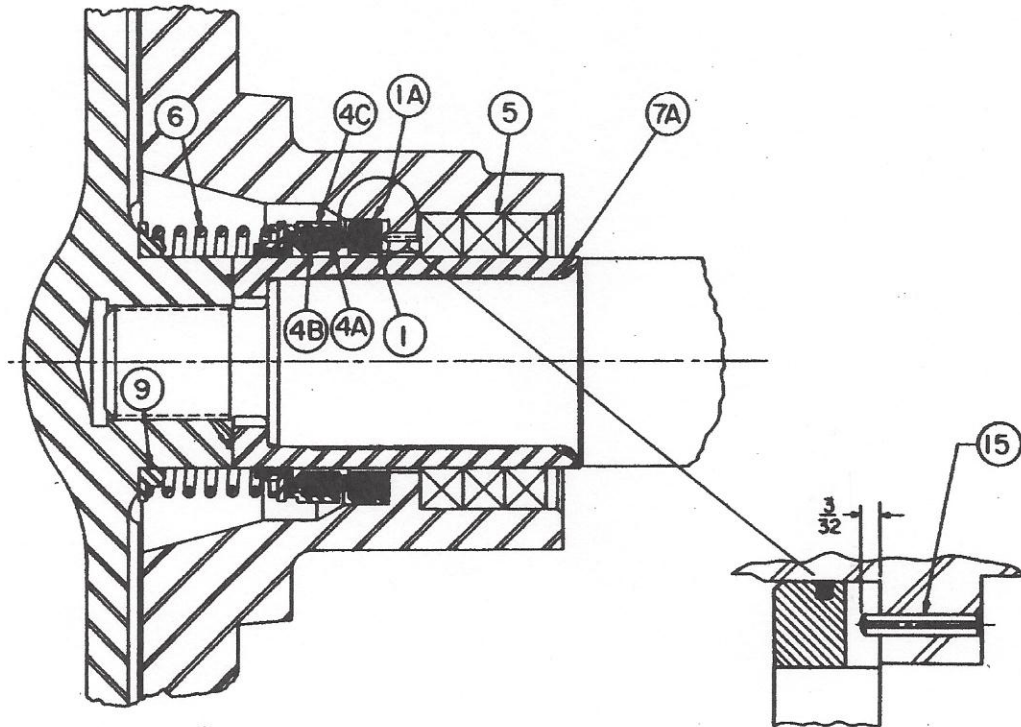

**Figure 8**  
**King Type Packing**

**Maintenance...**

**IV. ASSEMBLY**

**G. ASSEMBLY FIGURES 5 THRU 9(Continued)...**



**2 1/2" Mechanical Seal/Packing  
Figure 9**

Arrangement for Magnum I  
Pumps in Severe Service

Recommended Spare Parts  
Items 1, 4A, 4B, 4C, 5.

See Dwg. 17538 for Subassembly  
Part Nos. and Stuffing Box  
Conversion Unit.

Item	Qty.	Part Name
1	1	Stationary Seat
1A	1	Seat O-Ring
4A	1	Rotating Seal Ring
4B	1	Bellows
4C	1	Cage Assembly
5	3	Packing**
6	1	Spring
7A	1	Sleeve**
9	1	Spring Retainer
15	1	Spring Pin

\*\*These items are not included with seal.

## **Trouble Shooting Procedures...**

### **I. GENERAL**

NOTE: See also Trouble Shooting Guide.

#### **A. EXCESSIVE PACKING LEAKAGE and RAPID PACKING WEAROUT; SHAFT SLEEVE COATING WORN**

Remove the packing. Slide a wire, with a short section of the tip bent 90°, into the stuffing box. Run the “stylus” tip of the wire along the shaft sleeve. If deep grooves are noted the sleeve must be replaced. Excessive tightening of the packing will cause rapid sleeve failure.

#### **B. PACKING BURNED**

Replace the packing. Initial overtightening and attempting to run packing without leakage will cause the packing to burn. Once the packing is burned it becomes hard and will not squeeze down on the shaft causing uncontrollable leakage.

#### **C. EXCESSIVE STUFFING BOX PRESSURE**

Caused by excessive clearance between the impeller back vanes and the stuffing box cover and/or worn impeller back vanes. The solution is to readjust the impeller clearance. See previous section entitled “Assembly of Fluid End to Power Frame” listed under “Maintenance” in this manual.

NOTE: Trouble shooting of mechanical seals is left to the seal manufacturer. Consult the factory if the problems persist.

## Trouble Shooting Procedures...

### I. GENERAL

#### D. TROUBLE SHOOTING GUIDE

Causes	Noise/ Vibration	No Flow	Insufficient Flow	Insufficient Pressure	Excessive Power Required	Intermittent Flow	Short Bearing Life
Pump not primed		X	X				
Speed too low			X	X			
Excessive discharge head		X	X				
Insufficient NPSH available	X	X	X			X	
Impeller clogged		X	X			X	
Wrong direction of rotation			X	X			
Plugged suction or discharge line	X	X	X				
Foot valve or suction line not immersed deeply enough		X	X			X	
Impeller damaged		X	X	X			
Shaft packing or seal defective			X	X			
Impeller diameter too small			X	X			
Impeller diameter too large					X		
Excessive amount of air or gas in liquid				X		X	X
Speed too high					X		X
Total head lower than design					X		
Specific gravity or viscosity too high			X		X		X
Bent shaft	X				X		X
Improper electric motor wiring or voltage					X		
Rotating elements bind	X				X		X
Leaky suction line or shaft seal		X	X			X	
Misalignment	X				X		X
Bearings worn	X						X
Impeller out of balance	X						X
Suction or discharge piping not anchored	X						
Improper foundation	X						
Insufficient discharge head (excessive flow)	X			X	X	X	X
Improper lubricant or level							X
Impeller clearance too large			X	X	X		

## Mounting Dimensions...

### I. PUMP DIMENSIONS

All dimensions in inches. Not to be used for construction.

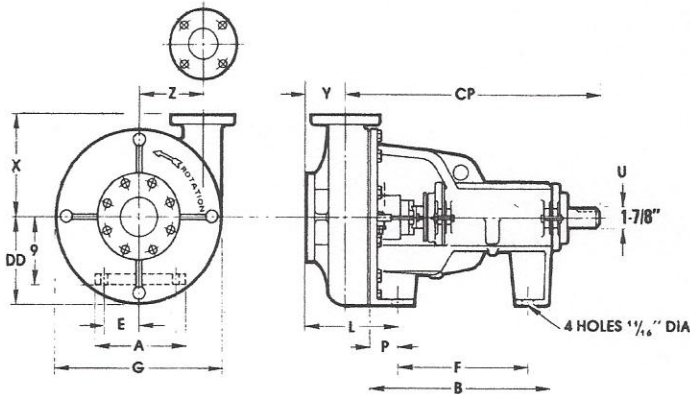

#### Pump Dimensions

All dimensions in inches. Not to be used for construction.

Size	Flange Dimensions*					
	ID	OD	BC	Thick-ness	No. of Holes	Size of Holes
2	2	6	4 <sup>3</sup> / <sub>4</sub>	5 <sup>8</sup> / <sub>8</sub>	4	3 <sup>4</sup> / <sub>4</sub>
3	3	7 <sup>1</sup> / <sub>2</sub>	6	3 <sup>4</sup> / <sub>4</sub>	4	3 <sup>4</sup> / <sub>4</sub>
4	4	9	7 <sup>1</sup> / <sub>2</sub>	15 <sup>15</sup> / <sub>16</sub>	8	3 <sup>4</sup> / <sub>4</sub>
5	5	10	8 <sup>1</sup> / <sub>2</sub>	15 <sup>15</sup> / <sub>16</sub>	8	7 <sup>8</sup> / <sub>8</sub>
6	6	11	9 <sup>1</sup> / <sub>2</sub>	1	8	7 <sup>8</sup> / <sub>8</sub>
8	8	13 <sup>1</sup> / <sub>2</sub>	11 <sup>3</sup> / <sub>4</sub>	1 <sup>1</sup> / <sub>8</sub>	8	7 <sup>8</sup> / <sub>8</sub>
10	10	16	14 <sup>1</sup> / <sub>4</sub>	13 <sup>13</sup> / <sub>16</sub>	12	1

\*The above drilling is standard 125 lb. Cast Iron or Series 150 Steel Flat Face.

Pump Size	Dimensions in inches												
	A	B	E	F	G	L	P	X	Y	Z	CP	DD	WT
3 x 2 x 13	9	19 <sup>5</sup> / <sub>8</sub>	3 <sup>1</sup> / <sub>2</sub>	15 <sup>7</sup> / <sub>16</sub>	17 <sup>7</sup> / <sub>8</sub>	8 <sup>3</sup> / <sub>4</sub>	2 <sup>5</sup> / <sub>16</sub>	10 <sup>1</sup> / <sub>4</sub>	3 <sup>3</sup> / <sub>4</sub>	7	29 <sup>1</sup> / <sub>4</sub>	8 <sup>15</sup> / <sub>16</sub>	440
4 x 3 x 13	9	19 <sup>5</sup> / <sub>8</sub>	3 <sup>1</sup> / <sub>2</sub>	15 <sup>7</sup> / <sub>16</sub>	17 <sup>7</sup> / <sub>8</sub>	9 <sup>3</sup> / <sub>8</sub>	2 <sup>5</sup> / <sub>16</sub>	10 <sup>1</sup> / <sub>4</sub>	4 <sup>1</sup> / <sub>4</sub>	6 <sup>3</sup> / <sub>4</sub>	29 <sup>3</sup> / <sub>8</sub>	8 <sup>15</sup> / <sub>16</sub>	436
5 x 4 x 14	9	19 <sup>5</sup> / <sub>8</sub>	3 <sup>1</sup> / <sub>2</sub>	15 <sup>7</sup> / <sub>16</sub>	19	10 <sup>3</sup> / <sub>4</sub>	2 <sup>5</sup> / <sub>16</sub>	11	5	6 <sup>1</sup> / <sub>8</sub>	30	9 <sup>1</sup> / <sub>2</sub>	485
6 x 5 x 11	9	19 <sup>5</sup> / <sub>8</sub>	3 <sup>1</sup> / <sub>2</sub>	15 <sup>7</sup> / <sub>16</sub>	17 <sup>7</sup> / <sub>8</sub>	12 <sup>1</sup> / <sub>16</sub>	2 <sup>5</sup> / <sub>16</sub>	11	5 <sup>3</sup> / <sub>4</sub>	6	30 <sup>5</sup> / <sub>8</sub>	8 <sup>15</sup> / <sub>16</sub>	507
6 x 5 x 14	9	19 <sup>5</sup> / <sub>8</sub>	3 <sup>1</sup> / <sub>2</sub>	15 <sup>7</sup> / <sub>16</sub>	21	12 <sup>1</sup> / <sub>16</sub>	2 <sup>5</sup> / <sub>16</sub>	11	5 <sup>3</sup> / <sub>4</sub>	6	30 <sup>5</sup> / <sub>8</sub>	10 <sup>1</sup> / <sub>2</sub>	550
8 x 6 x 11	9	19 <sup>5</sup> / <sub>8</sub>	3 <sup>1</sup> / <sub>2</sub>	15 <sup>7</sup> / <sub>16</sub>	20	13 <sup>1</sup> / <sub>4</sub>	2 <sup>5</sup> / <sub>16</sub>	14	6 <sup>1</sup> / <sub>4</sub>	8 <sup>3</sup> / <sub>8</sub>	31 <sup>1</sup> / <sub>4</sub>	10	583
8 x 6 x 14	9	19 <sup>5</sup> / <sub>8</sub>	3 <sup>1</sup> / <sub>2</sub>	15 <sup>7</sup> / <sub>16</sub>	23 <sup>9</sup> / <sub>16</sub>	13 <sup>1</sup> / <sub>4</sub>	2 <sup>5</sup> / <sub>16</sub>	14	6 <sup>1</sup> / <sub>4</sub>	8 <sup>3</sup> / <sub>8</sub>	31 <sup>1</sup> / <sub>4</sub>	11 <sup>13</sup> / <sub>16</sub>	616
10 x 8 x 14	9	19 <sup>5</sup> / <sub>8</sub>	3 <sup>1</sup> / <sub>2</sub>	15 <sup>7</sup> / <sub>16</sub>	22 <sup>3</sup> / <sub>8</sub>	13 <sup>1</sup> / <sub>16</sub>	2 <sup>5</sup> / <sub>16</sub>	14 <sup>3</sup> / <sub>16</sub>	6 <sup>11</sup> / <sub>16</sub>	8	31 <sup>1</sup> / <sub>4</sub>	11 <sup>3</sup> / <sub>16</sub>	810



## Mounting Dimensions (Continued)...

### II. PUMP and FABRICATED BASE

All dimensions in inches. Not to be used for construction.

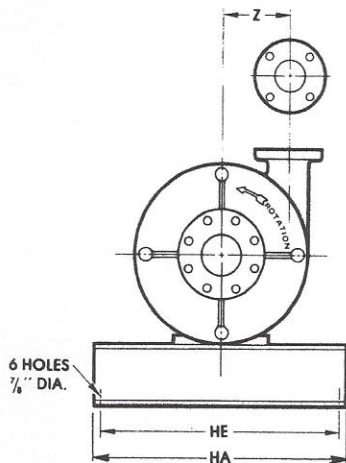

### Pump and Fabricated Base

All dimensions in inches. Not to be used for construction.

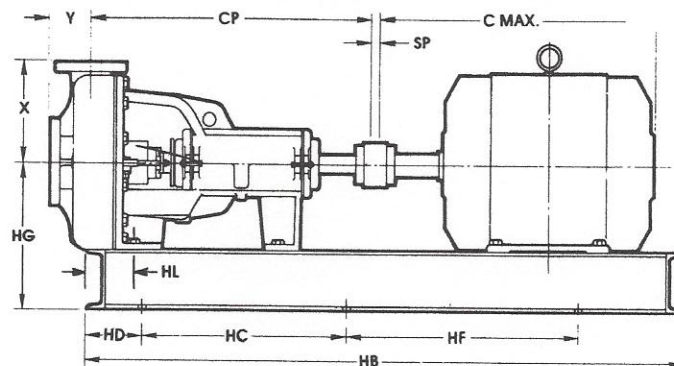

Motor Frames	Dimensions determined by motor											Base Wt.
	Base	C Max	HA	HB	HC	HD	HE	HF	HG	HL	SP*	
182T-215T	FB-5	19 <sup>13</sup> / <sub>32</sub>	13 <sup>7</sup> / <sub>16</sub>	47 <sup>3</sup> / <sub>4</sub>	13	3 <sup>23</sup> / <sub>32</sub>	12 <sup>1</sup> / <sub>2</sub>	22	13	4 <sup>7</sup> / <sub>8</sub>	1	109
254T-286T	FB-2	28 <sup>7</sup> / <sub>64</sub>	20 <sup>11</sup> / <sub>32</sub>	56 <sup>7</sup> / <sub>32</sub>	20	3 <sup>59</sup> / <sub>64</sub>	19	21	15	4 <sup>7</sup> / <sub>8</sub>	1	170
324T-326T	FB-2	31 <sup>1</sup> / <sub>8</sub>	20 <sup>11</sup> / <sub>32</sub>	56 <sup>7</sup> / <sub>32</sub>	20	3 <sup>59</sup> / <sub>64</sub>	19	21	15	4 <sup>7</sup> / <sub>8</sub>	1	170
364T-365T	FB-3	33 <sup>7</sup> / <sub>8</sub>	26 <sup>3</sup> / <sub>32</sub>	64 <sup>11</sup> / <sub>32</sub>	22	5 <sup>59</sup> / <sub>64</sub>	25	25	17	4 <sup>7</sup> / <sub>8</sub>	1	229
404T-405T	FB-3	37 <sup>63</sup> / <sub>64</sub>	26 <sup>3</sup> / <sub>32</sub>	64 <sup>11</sup> / <sub>32</sub>	22	5 <sup>59</sup> / <sub>64</sub>	25	25	17	4 <sup>7</sup> / <sub>8</sub>	1	229
444T-445T	FB-4	44 <sup>1</sup> / <sub>4</sub>	31 <sup>7</sup> / <sub>32</sub>	69 <sup>31</sup> / <sub>32</sub>	24	5 <sup>59</sup> / <sub>64</sub>	27 <sup>3</sup> / <sub>8</sub>	30	17 <sup>1</sup> / <sub>2</sub>	4 <sup>7</sup> / <sub>8</sub>	1	257

\*Unless spacer coupling is specified.

## Mounting Dimensions (Continued)...

### III. PUMP and CHANNEL BASE

All dimensions in inches. Not to be used for construction.

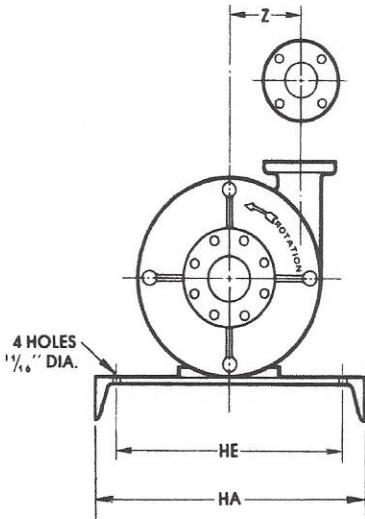

### Pump and Channel Base

All dimensions in inches. Not to be used for construction.

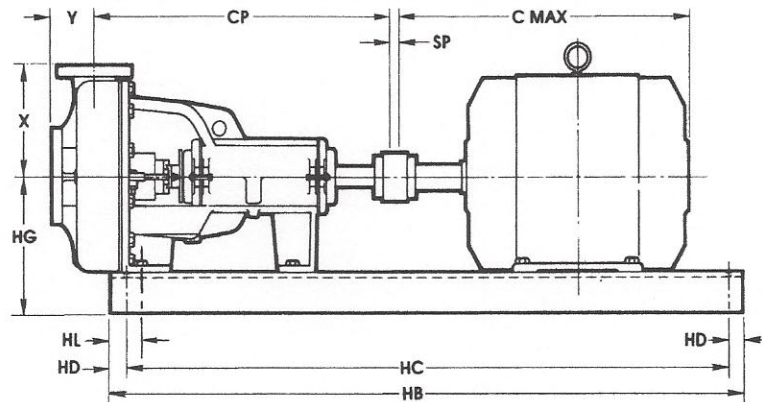

Motor Frames	Dimensions determined by motor										Base Wt.
	Base	C Max	HA	HB	HC	HD	HE	HG	HL	SP*	
182T-215T	15901-3	19 <sup>7</sup> / <sub>16</sub>	18	54 <sup>7</sup> / <sub>16</sub>	51 <sup>1</sup> / <sub>2</sub>	1 <sup>15</sup> / <sub>32</sub>	15 <sup>1</sup> / <sub>8</sub>	12 <sup>15</sup> / <sub>16</sub>	3	1	200
254T-286T	15901-3	28 <sup>1</sup> / <sub>8</sub>	18	54 <sup>7</sup> / <sub>16</sub>	51 <sup>1</sup> / <sub>2</sub>	1 <sup>15</sup> / <sub>32</sub>	15 <sup>1</sup> / <sub>8</sub>	12 <sup>15</sup> / <sub>16</sub>	3	1	200
324T-326T	15901-3	31 <sup>1</sup> / <sub>8</sub>	18	54 <sup>7</sup> / <sub>16</sub>	51 <sup>1</sup> / <sub>2</sub>	1 <sup>15</sup> / <sub>32</sub>	15 <sup>1</sup> / <sub>8</sub>	12 <sup>15</sup> / <sub>16</sub>	3	1	200
364T-365T	15901-5	33 <sup>7</sup> / <sub>8</sub>	18	63	60	1 <sup>1</sup> / <sub>2</sub>	15 <sup>1</sup> / <sub>8</sub>	12 <sup>15</sup> / <sub>16</sub>	3	1	250
404T-405T	19789	38	21	72	69	1 <sup>1</sup> / <sub>2</sub>	18	14	3	1	300
444T-445T	19789	44 <sup>1</sup> / <sub>4</sub>	21	72	69	1 <sup>1</sup> / <sub>2</sub>	18	15	3	1	300

\*Unless spacer coupling is specified.

## Mounting Dimensions (Continued)...

### IV. PUMP and SKID BASE

All dimensions in inches. Not to be used for construction.

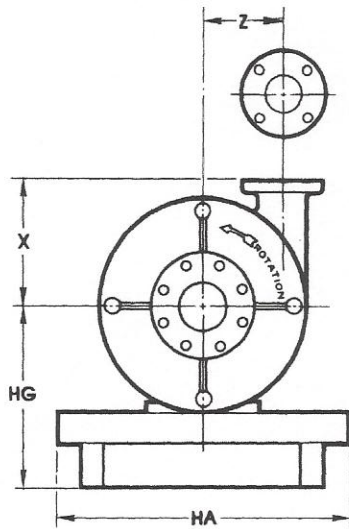

### Pump and Skid Base

All dimensions in inches. Not to be used for construction.

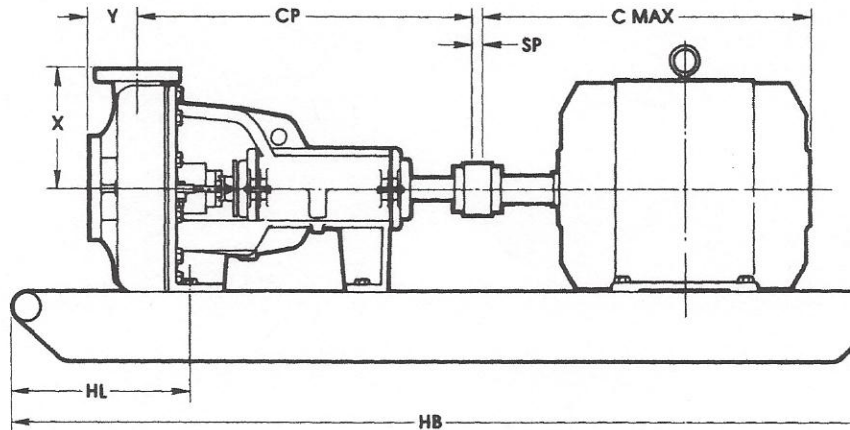

Motor Frames	Dimensions determined by motor							Base Wt.
	Base	C Max	HA	HB	HG	HL	SP*	
182T-215T	FSB-5	19 <sup>13</sup> / <sub>32</sub>	25 <sup>1</sup> / <sub>2</sub>	66 <sup>3</sup> / <sub>8</sub>	13	17 <sup>5</sup> / <sub>32</sub>	1	158
254T-286T	FSB-2	28 <sup>7</sup> / <sub>64</sub>	34 <sup>3</sup> / <sub>4</sub>	80 <sup>3</sup> / <sub>16</sub>	15	17 <sup>3</sup> / <sub>8</sub>	1	241
324T-326T	FSB-2	31 <sup>1</sup> / <sub>8</sub>	34 <sup>3</sup> / <sub>4</sub>	80 <sup>3</sup> / <sub>16</sub>	15	17 <sup>3</sup> / <sub>8</sub>	1	241
364T-365T	FSB-2	33 <sup>7</sup> / <sub>8</sub>	34 <sup>3</sup> / <sub>4</sub>	80 <sup>3</sup> / <sub>16</sub>	15	17 <sup>3</sup> / <sub>8</sub>	1	241
404T-405T	FSB-3	37 <sup>63</sup> / <sub>64</sub>	45 <sup>1</sup> / <sub>4</sub>	89 <sup>7</sup> / <sub>16</sub>	17	18 <sup>3</sup> / <sub>8</sub>	1	317
444T-445T	FSB-4	44 <sup>1</sup> / <sub>4</sub>	48 <sup>1</sup> / <sub>4</sub>	98 <sup>15</sup> / <sub>16</sub>	17 <sup>1</sup> / <sub>2</sub>	18 <sup>3</sup> / <sub>8</sub>	1	349

\*Unless spacer coupling is specified.

## Mounting Dimensions (Continued)...

### V. 2½ SHAFT MAGNUM PUMPS with FABRICATED BASES for T FRAME MOTORS

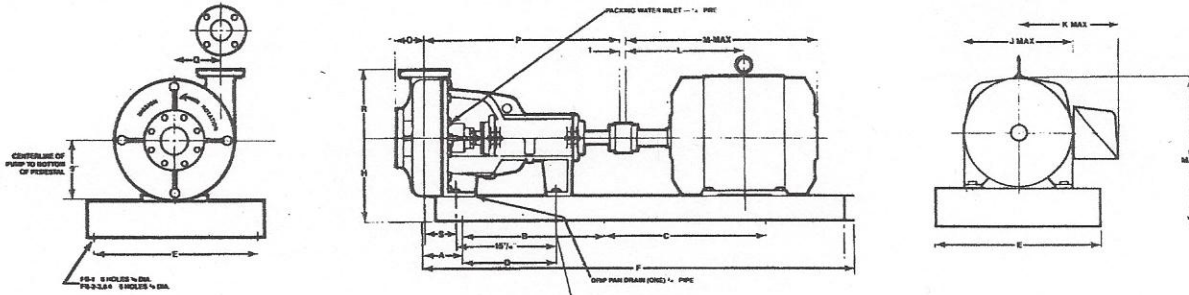

Pump Size	Discharge Pipe		Suction Pipe Size	Drilling	O	P	Q	R	S
	Size	Drilling							
3 x 2	2	4 Holes ¾ D. 4¾ B.C.	3	4 Holes ¾ D. 6 B.C.	3¾	29¾	7	10¼	5
4 x 3	3	4 Holes ¾ D. 6 B.C.	4	8 Holes ¾ D. 7½ B.C.	4¼	29⅞	6¾	10¼	5½
5 x 4	4	8 Holes ¾ D. 7½ B.C.	5	8 Holes ¾ D. 8½ B.C.	5	30⅞	6½	11	5¾
6 x 5 x 11	5	8 Holes ¾ D. 8½ B.C.	6	8 Holes ¾ D. 9½ B.C.	5¾	30%	6	11	6 <sup>5</sup> / <sub>16</sub>
6 x 5 x 14	5	{ 6 Holes ¾ D. 8½ B.C. 2 Holes (Note) 8½ B.C. }	6	8 Holes ¾ D. 9½ B.C.	5¾	30%	6	11	6 <sup>5</sup> / <sub>16</sub>
8 x 6 x 11	6	8 Holes ¾ D. 9½ B.C.	8	8 Holes ¾ D. 11¾ B.C.	6¼	31 <sup>5</sup> / <sub>16</sub>	8¾	14	7
8 x 6 x 14	6	8 Holes ¾ D. 9½ B.C.	8	8 Holes ¾ D. 11¾ B.C.	6¼	31 <sup>5</sup> / <sub>16</sub>	8¾	14	7

Note: Drilling is standard 125 lb. cast iron or series 150 flat face steel flange except 6 x 5 x 14 discharge with two holes tapped ¾-1 UNJC-28

Motor Frame	F. B. Base No.	Dimensions													
		A	B	C	D	E	F	G	H	J	K	L	M	N	
182T	1	3¾	13	22	16 <sup>7</sup> / <sub>16</sub>	12½	46 <sup>1</sup> / <sub>8</sub>	13½	17%	9%	7¼	7¾	14 <sup>9</sup> / <sub>16</sub>	13	
184T	1	3¾	13	22	16 <sup>7</sup> / <sub>16</sub>	12½	46 <sup>1</sup> / <sub>8</sub>	13½	17%	9%	7¼	8¼	15 <sup>5</sup> / <sub>16</sub>	13	
213T	1	3¾	13	22	16 <sup>7</sup> / <sub>16</sub>	12½	46 <sup>1</sup> / <sub>8</sub>	13½	18½	11	9¼	9%	17 <sup>7</sup> / <sub>8</sub>	13	
215T	1	3¾	13	22	16 <sup>7</sup> / <sub>16</sub>	12½	46 <sup>1</sup> / <sub>8</sub>	13½	18½	11	9¼	10%	19 <sup>7</sup> / <sub>16</sub>	12	
254T	2	3¾	20	21	16 <sup>7</sup> / <sub>16</sub>	19	56	20¼	21½	13	10½	12%	22¾	15	
256T	2	3¾	20	21	16 <sup>7</sup> / <sub>16</sub>	19	56	20¼	21½	13	10½	13¼	24 <sup>9</sup> / <sub>16</sub>	15	
284T	2	3¾	20	21	16 <sup>7</sup> / <sub>16</sub>	19	56	20¼	22¼	14½	12 <sup>5</sup> / <sub>16</sub>	14 <sup>1</sup> / <sub>8</sub>	26%	15	
284TS	2	3¾	20	21	16 <sup>7</sup> / <sub>16</sub>	19	56	20¼	22¼	14½	12 <sup>5</sup> / <sub>16</sub>	12¾	25¼	15	
286T	2	3¾	20	21	16 <sup>7</sup> / <sub>16</sub>	19	56	20¼	22¼	14½	12 <sup>5</sup> / <sub>16</sub>	14 <sup>1</sup> / <sub>8</sub>	28 <sup>1</sup> / <sub>8</sub>	15	
286TS	2	3¾	20	21	16 <sup>7</sup> / <sub>16</sub>	19	56	20¼	22¼	14½	12 <sup>5</sup> / <sub>16</sub>	13½	26¾	15	
324T	2	3¾	20	21	16 <sup>7</sup> / <sub>16</sub>	19	56	20¼	23½	16 <sup>1</sup> / <sub>8</sub>	14 <sup>7</sup> / <sub>16</sub>	15¾	28 <sup>15</sup> / <sub>16</sub>	15	
324TS	2	3¾	20	21	16 <sup>7</sup> / <sub>16</sub>	19	56	20¼	23½	16 <sup>1</sup> / <sub>8</sub>	14 <sup>7</sup> / <sub>16</sub>	14¼	28 <sup>1</sup> / <sub>8</sub>	15	
326T	2	3¾	20	21	16 <sup>7</sup> / <sub>16</sub>	19	56	20¼	23½	16 <sup>1</sup> / <sub>8</sub>	14 <sup>7</sup> / <sub>16</sub>	16½	31 <sup>1</sup> / <sub>8</sub>	15	
326TS	2	3¾	20	21	16 <sup>7</sup> / <sub>16</sub>	19	56	20¼	23½	16 <sup>1</sup> / <sub>8</sub>	14 <sup>7</sup> / <sub>16</sub>	15	29%	15	
364T	3	6	22	25	14 <sup>1</sup> / <sub>16</sub>	25	64 <sup>1</sup> / <sub>8</sub>	26¼	26½	19	16½	17%	33 <sup>7</sup> / <sub>16</sub>	17	
364TS	3	6	22	25	14 <sup>1</sup> / <sub>16</sub>	25	64 <sup>1</sup> / <sub>8</sub>	26¼	26½	19	16½	15¼	31 <sup>5</sup> / <sub>16</sub>	17	
365T	3	6	22	25	14 <sup>1</sup> / <sub>16</sub>	25	64 <sup>1</sup> / <sub>8</sub>	26¼	26½	19	16½	17%	33%	17	
365TS	3	6	22	25	14 <sup>1</sup> / <sub>16</sub>	25	64 <sup>1</sup> / <sub>8</sub>	26¼	26½	19	16½	15¾	31¾	17	
404T	3	6	22	25	14 <sup>1</sup> / <sub>16</sub>	25	64 <sup>1</sup> / <sub>8</sub>	26¼	28%	22¼	17%	20	36%	17	
404TS	3	6	22	25	14 <sup>1</sup> / <sub>16</sub>	25	64 <sup>1</sup> / <sub>8</sub>	26¼	28%	22¼	17%	17	33%	17	
405T	3	6	22	25	14 <sup>1</sup> / <sub>16</sub>	25	64 <sup>1</sup> / <sub>8</sub>	26¼	28%	22¼	17%	20%	38%	17	
405TS	3	6	22	25	14 <sup>1</sup> / <sub>16</sub>	25	64 <sup>1</sup> / <sub>8</sub>	26¼	28%	22¼	17%	17¾	35%	17	
444T	4	6	24	30	14 <sup>1</sup> / <sub>16</sub>	27%	69¾	28 <sup>3</sup> / <sub>8</sub>	30	23½	20¾	23¼	42%	17½	
444TS	4	6	24	30	14 <sup>1</sup> / <sub>16</sub>	27%	69¾	28 <sup>3</sup> / <sub>8</sub>	30	23½	20¾	19½	38 <sup>3</sup> / <sub>8</sub>	17½	
445T	4	6	24	30	14 <sup>1</sup> / <sub>16</sub>	27%	69¾	28 <sup>3</sup> / <sub>8</sub>	30	23½	20¾	24¼	44%	17½	
445TS	4	6	24	30	14 <sup>1</sup> / <sub>16</sub>	27%	69¾	28 <sup>3</sup> / <sub>8</sub>	30	23½	20¾	20½	40%	17½	

**Mounting Dimensions (Continued)...**

**VI. DUTY MASTER ALTERNATING CURRENT MOTORS**

Enclosure: Totally Enclosed  
Underwriters Classification

Class I, Group D  
Class II, Group E, F and G  
Frames 182T Thur 440TS

Mounting: Foot

Cooling: Fan Cooled

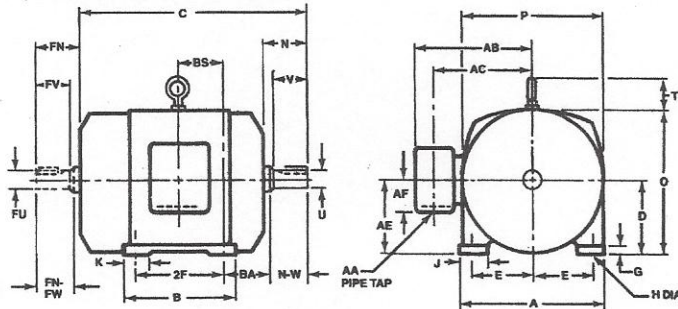

Dimensions are in inches

Frame	A	D(2)	E	G	H	J	O	P	AA	AB	AC	AF	BA	AE	K	T
182T - 184T	9.00	4.50	3.75	.44	.44	1.75	9.12	9.50	3/4	9.38	6.94	2.50	2.88	4.50	1.88	2.00
213T - 215T	10.50	5.25	4.25	.44	.44	2.00	10.50	11.00	1	10.25	7.81	2.50	3.62	5.25	1.88	2.00
254T - 256T	12.50	5.25	5.00	.62	.56	2.50	12.50	13.12	1 1/4	12.38	9.69	3.38	4.38	6.25	2.62	2.00
284T - 286TS	13.75	7.00	5.50	.62	.56	2.50	14.00	14.62	1 1/4	13.25	10.56	3.38	4.88	7.00	2.75	2.38
324T - 326TS	15.50	8.00	6.25	.62	.69	2.75	16.00	16.62	2	17.06	12.50	4.25	5.38	8.00	3.12	2.94
364T - 365TS	17.00	9.00	7.00	.88	.69	2.75	18.50	19.50	3	18.81	14.25	4.25	6.00	9.00	3.88	2.94
404T - 405TS	19.00	10.00	8.00	1.12	.81	3.25	21.31	22.50	3	20.50	15.88	4.25	6.75	10.00	3.25	2.94
444T - 445TS	21.00	11.00	9.00	1.12	.81	3.25	24.00	25.25	3	26.25	20.38	6.00	7.62	11.00	3.25	3.25

Frame	C	BS	B	Back End Shaft			U(3)	B. E. Key		Front End Shaft				F. E. Key		Wt. Lgth.	Lbs.
				2F	N	N-W		V	Sq.	Lgth.	FN	FN-FW	FU(3)	FV	Sq.		
182T	14.58	2.25	6.00	4.50	2.94	2.75	1.125	2.50	.250	1.75	3.19	2.25	.875	2.00	.188	1.38	90
184T	15.56	2.75	7.00	5.50	2.94	2.75	1.125	2.50	.250	1.75	3.19	2.25	.875	2.00	.188	1.38	125
213T	17.75	2.75	7.00	5.50	3.56	3.38	1.375	3.12	.312	2.38	3.75	2.75	1.125	2.50	.250	1.75	137
215T	19.25	3.50	8.50	7.00	3.56	3.38	1.375	3.12	.312	2.38	3.75	2.75	1.125	2.50	.250	1.75	154
254T	22.75	4.12	10.25	8.25	4.25	4.00	1.625	3.75	.375	2.88	4.62	3.38	1.375	3.12	.312	2.38	238
256T	24.50	5.00	12.00	10.00	4.25	4.00	1.625	3.75	.375	2.88	4.62	3.38	1.375	3.12	.312	2.38	263
284T	25.94	4.75	11.50	9.50	4.88	4.62	1.875	4.38	.500	3.25	5.50	4.00	1.675	3.75	.375	2.88	366
284TS	24.56	4.75	11.50	9.50	3.50	3.25	1.625	3.00	.375	1.88	4.75	3.25	1.625	3.00	.375	1.88	366
286T	27.44	5.50	13.00	11.00	4.88	4.62	1.875	4.38	.500	3.25	5.50	4.00	1.625	3.75	.375	2.88	385
286TS	26.06	5.50	13.00	11.00	3.50	3.25	1.625	3.00	.375	1.88	4.75	3.25	1.625	3.00	.375	1.88	385
324T	28.94	5.25	13.25	10.50	5.50	5.25	2.125	5.00	.500	3.88	6.12	4.62	1.875	4.38	.500	3.25	554
324TS	27.44	5.25	13.25	10.50	4.00	3.75	1.875	3.50	.500	2.00	5.25	3.75	1.875	3.50	.500	2.00	554
326T	30.44	6.00	14.75	12.00	5.50	5.25	2.125	5.00	.500	3.88	6.12	4.62	1.875	4.38	.500	3.25	552
326TS	28.94	6.00	14.75	12.00	4.00	3.75	1.875	3.50	.500	2.00	5.25	3.75	1.875	3.50	.500	2.00	552
364T	33.44	6.12	15.00	11.25	6.12	5.88	2.375	5.62	.625	4.25	6.50	5.25	1.875	5.00	.500	3.25	808
364TS	31.31	6.12	15.00	11.25	4.00	3.75	1.875	3.50	.500	2.00	5.62	3.75	1.875	3.50	.500	2.00	808
365T	33.44	6.12	15.00	12.25	6.12	5.88	2.375	5.62	.625	4.25	6.50	5.25	1.875	5.00	.500	3.25	874
365TS	31.31	6.12	15.00	12.25	4.00	3.75	1.875	3.50	.500	2.00	5.62	3.75	1.875	3.50	.500	2.00	874
404T	36.88	6.12	14.50	12.25	7.62	7.25	2.875	7.00	.750	5.62	8.00	5.25	2.125	5.00	.500	3.88	975
404TS	33.88	6.12	14.50	12.25	4.62	4.25	2.125	4.00	.500	2.75	7.00	4.25	2.125	4.00	.500	2.75	975
405T	38.38	6.88	16.00	13.75	7.62	7.25	2.875	7.00	.750	5.62	8.00	5.25	2.125	5.00	.500	3.88	1100
405TS	35.38	6.88	16.00	13.75	4.62	4.25	2.125	4.00	.500	2.75	7.00	4.25	2.125	4.00	.500	2.75	1100
444T	42.62	7.25	17.00	14.50	8.94	8.50	3.375	8.25	.875	6.88	8.88	5.88	2.375	5.62	.625	4.25	1350
444TS	38.88	7.25	17.00	14.50	5.19	4.75	2.375	4.50	.625	3.00	7.75	4.75	2.375	4.50	.625	3.00	1350
445T	44.62	8.25	19.00	16.50	8.94	8.50	3.375	8.25	.875	6.88	8.88	5.62	2.375	5.62	.625	4.25	1500
445TS	40.78	8.25	19.00	16.50	5.19	4.75	2.375	4.50	.625	3.00	7.75	4.75	2.375	4.50	.625	3.00	1500

(2) "D" varies +.00, -.30, 182T to 360T, +.00, -.06, 400T to 440T.  
(3) "U" and "FU" vary — Up to 1.625 Dia. + .0000 — .0005  
1.625 and Larger +.000, —.001.  
Walls or constructions must not encroach upon air inlet space "FW".

Std. double shaft supplied only when specified conduit box located on opposite side when F-2, W-1, W-4, W-5, W-7, or C-1 mounting is specified.

If mounting clearance details are required, consult factory.

Maximum permissible shaft runout when measured at end of std. shaft extension is .002 T.I.R. up to and including 1.625 dia. and .003 T.I.R. 1.625 to 5 inch dia.

## Engineering Data...

### I. SUCTION PIPING

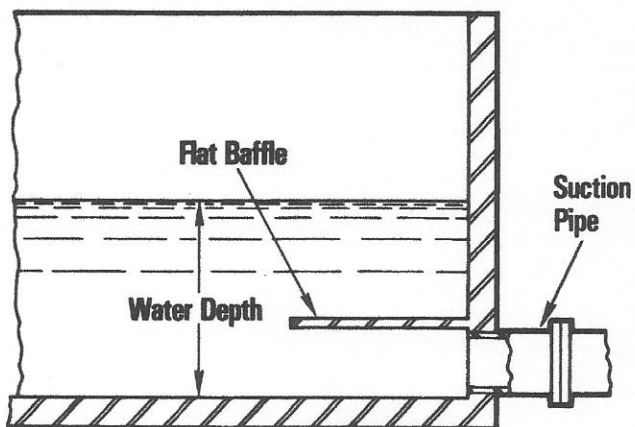

Side View

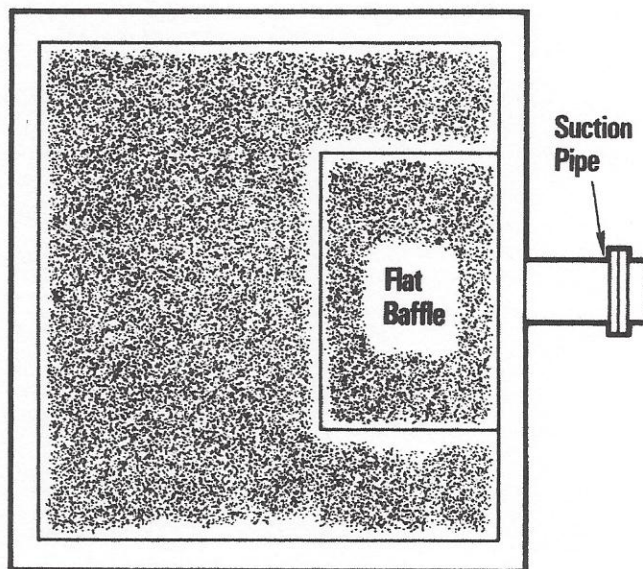

Top View

Vortex can be prevented by  
proper baffle arrangements.

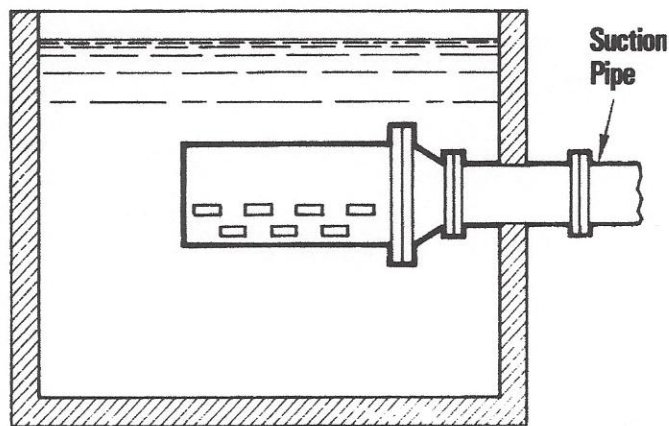

**Engineering Data...**

**I. SUCTION PIPING (Continued)...**

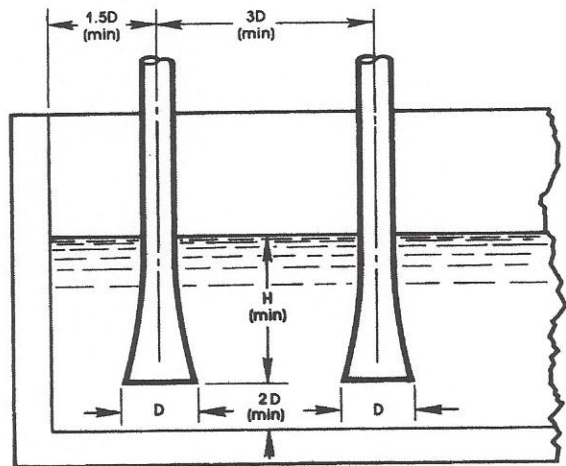
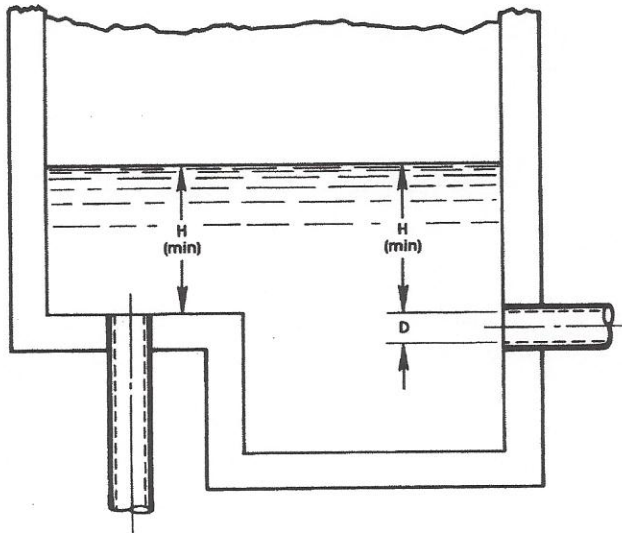
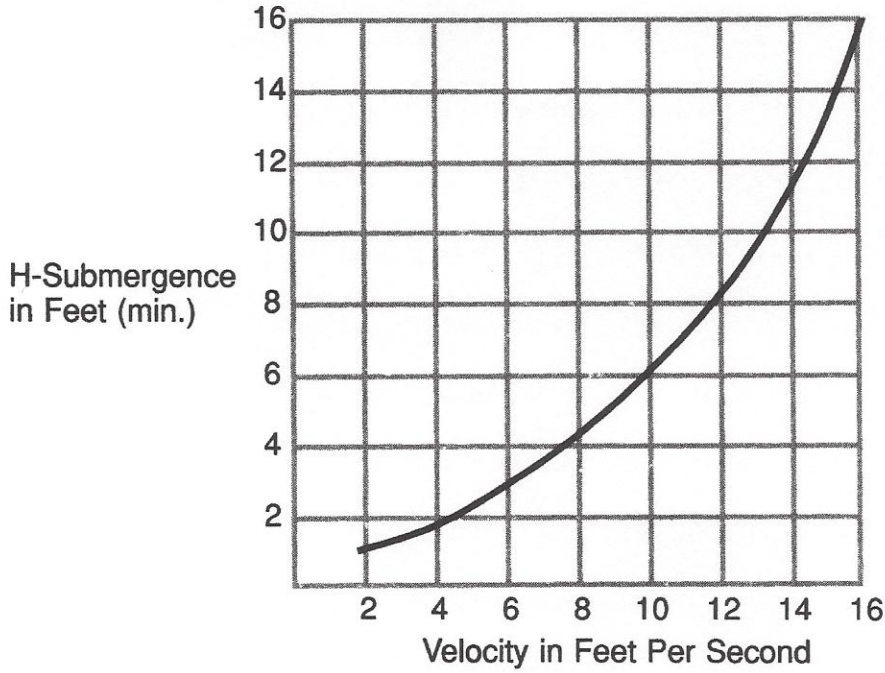

This can be used as a guide for minimum submergence and piping design.

$$\text{Velocity, feet per second} = \frac{\text{GPM} \times .4}{D^2 \text{ (inches)}}$$

**Engineering Data...**

**I. SUCTION PIPING (Continued)...**

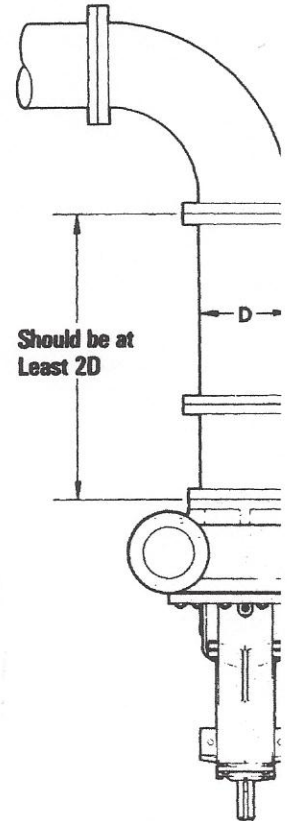
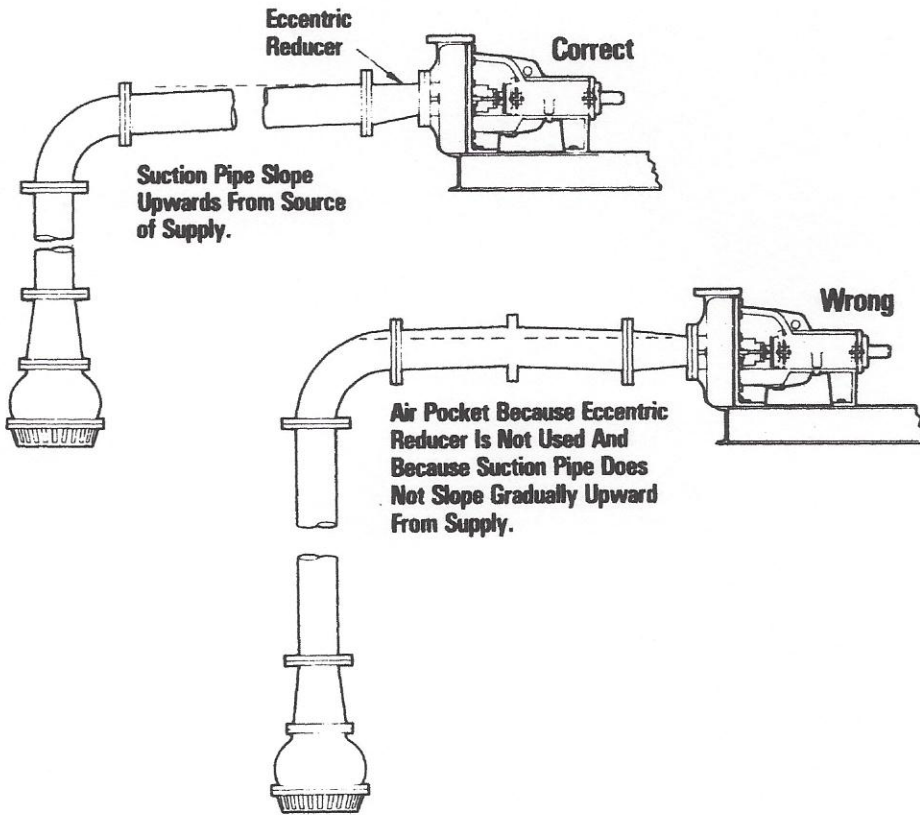



## Engineering Data...

### I. SUCTION PIPING (Continued)...

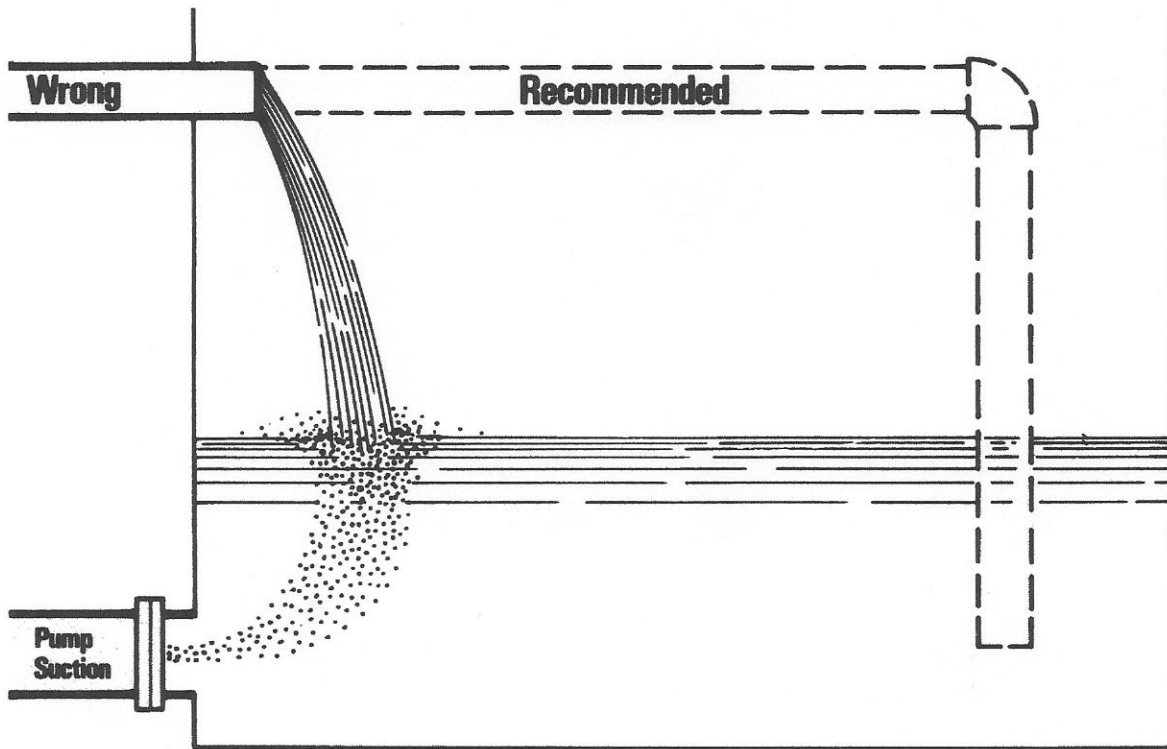

## Engineering Data...

### I. SUCTION PIPING (Continued)...

#### Engineering Data

##### Conversion Data

$$\text{GPM} = .03 \times \text{Barrels per day}$$

$$\text{Specific gravity} = \frac{\text{weight fluid in pounds/gal.}}{8.34}$$

$$\text{SP. GR.} = \frac{\text{pounds/cu. ft.}}{62.4}$$

$$\text{Feet Head} = \frac{\text{PSI} \times 2.31}{\text{SP. GR.}}$$

$$\text{PSI} = \frac{\text{Feet Head} \times \text{SP. GR.}}{2.31}$$

$$\text{Brake Horsepower Required} = \text{Curved Horsepower} \times \text{SP. GR.}$$

$$\text{Pounds per Gallon} = .133 \times \text{pounds/cu. ft.}$$

##### Metric Conversions:

$$\text{GPM} = .264 \times \text{liters/min.}$$

$$\text{GPM} = 15.9 \times \text{liters/sec.}$$

$$\text{GPM} = 4.4 \times \text{meters}^3/\text{hr.}$$

$$\text{GPM} = 264 \times \text{meters}^3/\text{min.}$$

$$\text{Feet} = 3.28 \times \text{meters}$$

$$\text{PSI} = 14.2 \times \text{Kg/cm}^2$$

$$\text{SP. GR.} = 1 \times \text{grams/cu. cm.}$$

##### Flow

Barrels/ Hour	Barrels/ Day	GPM
4.2	100	3
10.5	250	7.5
21	500	15
31.5	750	22.5
42	1000	30
63	1500	45
83	2000	60
125	3000	90
208	5000	150
312	7500	225
420	10,000	300

##### To determine horsepower for pumping weighted fluids

The Pump Performance Curves show horsepower for pumping clear water with a specific gravity of 1 and a weight of 8.34 lb/gal. For fluids with a higher specific gravity than plain water, correct the Pump Performance Curves in the following manner:

1. Find the fluid weight in lb/gal.
2. Multiply horsepower shown on the curve by fluid weight in lb/gal., then divide by 8.34.

$$\text{Corrected HP} = \frac{\text{Curve Brake HP} \times \text{Fluid Wt./Gallon}}{8.34}$$

##### Head - For water, Sp. Gr. = 1.0

Feet	Psi	Psi	Feet
10	4.33	10	23.1
20	8.66	20	46.2
25	10.8	25	57.8
30	13	30	69.3
40	17.3	35	80.9
50	21.6	40	92.4
75	32.48	45	104
100	43.2	50	115.5
150	64.8	60	138.6
200	86.4	75	173.2
250	108	100	231
300	130	125	288.7
350	151.6	150	346.5
400	172.8	175	404.2
450	195	200	462

## Engineering Data...

### I. SUCTION PIPING (Continued)...

#### Theoretical Discharge of Nozzles in U.S. Gallons Per Minute

Head*	lb.	Feet	Velocity of disch ft/sec.	Diameter of nozzle in inches														
				3/8	1/2	5/8	3/4	7/8	1	1 1/8	1 1/4	1 3/8	1 1/2	1 3/4	2	2 1/4	2 1/2	2 3/4
10	23.13	38.6	13.3	23.6	36.9	53.1	72.4	94.5	120	148	179	213	289	378	479	591	714	851
15	4.6	47.25	16.3	28.9	45.2	65.0	88.5	116.0	147	181	219	260	354	463	585	723	874	1041
20	46.2	54.55	18.8	33.4	52.2	75.1	102.0	134.0	169	209	253	301	409	535	676	835	1009	1203
25	57.7	61.0	21.0	37.3	58.3	84.0	114.0	149.0	189	234	283	336	458	598	756	934	1128	1345
30	69.3	66.85	23.0	40.9	63.9	92.0	125.0	164.0	207	256	309	368	501	655	828	1023	1236	1473
35	80.8	72.2	24.8	44.2	69.0	99.5	135.0	177.0	224	277	334	398	541	708	895	1106	1335	1591
40	92.4	77.2	26.6	47.3	73.8	106.0	145.0	188.0	239	296	357	425	578	756	957	1182	1428	1701
45	103.9	81.8	28.2	50.1	78.2	113.0	153.0	200.0	253	313	379	451	613	801	1015	1252	1512	1802
50	115.5	86.25	29.7	52.8	82.5	119.0	162.0	211.0	267	330	399	475	647	845	1070	1320	1595	1900
55	127.0	90.5	31.1	55.3	86.4	125.0	169.0	221.0	280	346	418	498	678	886	1121	1385	1671	1991
60	138.6	94.6	32.5	57.8	90.4	130.0	177.0	231.0	293	362	438	521	708	926	1172	1447	1748	2085
65	150.1	98.3	33.8	60.2	94.0	136.0	184.0	241.0	305	376	455	542	737	964	1220	1506	1819	2165
70	161.7	102.1	35.2	62.5	97.7	141.0	191.0	250.0	317	391	473	563	765	1001	1267	1565	1888	2250
75	173.2	105.7	36.4	64.7	101.0	146.0	198.0	259.0	327	404	489	582	792	1037	1340	1619	1955	2330
80	184.8	109.1	37.6	66.8	104.0	150.0	205.0	267.0	338	418	505	602	818	1070	1354	1672	2020	2405
85	196.3	112.5	38.8	68.9	108.0	155.0	211.0	276.0	349	431	521	620	844	1103	1395	1723	2080	2480
90	207.9	115.8	39.9	70.8	111.0	160.0	217.0	284.0	359	443	536	638	868	1136	1436	1773	2140	2550
95	219.4	119.0	41.0	72.8	114.0	164.0	223.0	292.0	369	456	551	656	892	1168	1476	1824	2200	2625
100	230.9	122.0	42.1	74.7	117.0	168.0	229.0	299.0	378	467	565	672	915	1196	1512	1870	2255	2690

\*Head loss across nozzle. The actual quantity discharged by a nozzle will be less than above table.

A well tapered smooth nozzle may be assumed to give 97 to 99% of the values in the tables.

# NATIONAL OILWELL VARCO

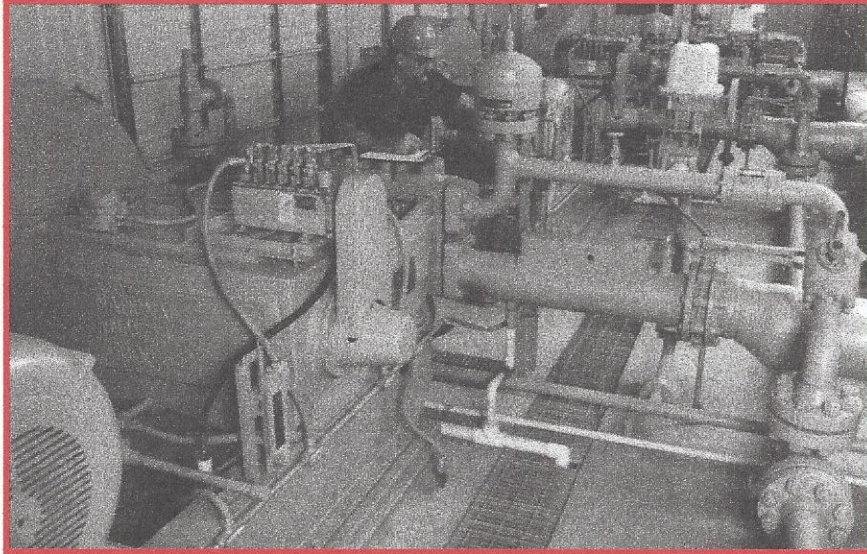

With over 120 locations worldwide, National Oilwell Varco is located near you. To find the nearest Distribution Service Center, machinery center or repair facility, please give us a call at our main office listed below.

Or you can access our website at the URL listed below, where you may search by location or country.

<http://www.natoil.com/locations>

**Sales/Technical Information:**  
**USA Tollfree:** 1 (800) 800-4110

**Internet:** <http://www.natoil.com>

National Oilwell Varco is a leading manufacturer of reciprocating plunger pumps, Mission Fluid King centrifugal pumps, and fluid end replacement parts. We also offer a complete set of solutions to your fluid transfer challenges. For more information, contact National Oilwell Varco directly at the Headquarters in Houston, Texas. All National Oilwell Varco products are available throughout the U.S. and around the world from service centers, authorized distributors, and representatives.

© Copyright 1999 by National Oilwell, L.P. All Rights Reserved. NATIONAL OILWELL, NATIONAL, and OILWELL are registered trademarks of NATIONAL OILWELL, L.P. Houston, Texas, USA. All other trademarks used are registered to their respective companies. The information and data in this brochure, including but not limited to pictures, photographs, charts, diagrams, drawings, lists, written comments, and specifications, are accurate to the best of our knowledge and belief, but are intended for general information only. Applications suggested for the materials and other information are described only to help readers make their own evaluations and decisions, and are neither guarantees nor are they to be construed as express or implied warranties of suitability for these or other applications. National Oilwell makes no warranty, either express or implied, beyond that stipulated in National Oilwell's Standard Terms and Conditions of Sale which are available upon request.