

**OPERATION - ASSEMBLY INSTRUCTIONS AND PARTS LIST FOR
“L4” DRIVE END**

(FRAME SIZES 1L4, 2L4, 3L4, 3M3, 6M3, 3P2, 6P2, 9P2)

GENERAL

The Robbins & Myers Moyno® Pump is one of the most versatile pumps available. It has been proven in thousands of applications over the past 50 years. It is backed by the experience gained over the years, both in application and manufacturing know-how.

The Moyno progressing cavity pump is a single-screw rotary pump. The pumping action is created by the single helical rotor rolling eccentrically in the double threaded helix of the stator. In its revolution, the rotor forms in conjunction with the stator a series of sealed cavities 180 degrees apart. As the rotor turns the cavities progress from the suction to the discharge. As one cavity diminishes, the opposing cavity is increasing at exactly the same rate. Thus, the sum of the two discharges is a constant volume. The result is a pulsation-less positive displacement flow with no valves.

WARNING

1. Enclose all rotating belts, pulleys, drive shafts, etc., to comply with acceptable industry safety standards for rotating equipment. Failure to comply could result in personal injury.
2. All pulleys have speed limitations. Refer to pulley manufacturer's literature for specifications and follow all recommendations, to prevent personal injury.

NAMEPLATE DATA

The Moyno Pump nameplate, located on the bearing housing, carries the serial number, frame size, and type designation. All are extremely important and must be used when ordering spare parts.

Record the nameplate data of your pump in the spaces provided in the heading of Page 3.

Moyno Pumps are identified by Frame and Type. Pump Frame is essentially an indication of size. It consists of a number, a letter, and a number (i.e. 2L4). The first number indicates the number of stages in the pumping elements. The letter indicates the model. The final number indicates the size of the rotor-stator pumping elements. A frame 2L4 pump, therefore, has two stages of size 4 pumping elements.

The "L" in the frame size indicates a standard relationship between the housing, bearings, and drive shaft and the size of the pumping elements. Many variations may be made by adapting smaller element sizes to a larger drive end size. This may be necessary due to the severity of a specific pumping application. In cases where the drive end (housing, bearings, and drive shaft) is one size larger than the element size normally used, the pump is referred to

as an "M" frame pump (i.e. 3M3). If the drive end is two sizes larger than the element size, the pump is referred to as a "P" frame. Thus, a frame 3L4, 3M3, and 3P2 would all use a common drive end.

Type designation is a series of letters which identify the "Materials of Construction" in component groups of parts. The usual type designation will consist of three letters.

The first letter identifies the material of the suction housing casting or the body casting where the bearing housing is a part of the suction housing.

C — Cast Iron
E — Alloy cb-20 Stainless
H — Hastelloy "C"
M — Monel
S — 316 Stainless Steel
W — Cast Steel (Available only on 1L14 body)
X — Special to application

The second letter indicates the material used in the drive shaft, pins, connecting rod, rotor, and other minor metallic parts in contact with the material being pumped.

D — Alloy Steel
E — Alloy cb-20 Stainless
G — 416 Stainless Steel
H — Hastelloy "C"
J — 17-4 PH Stainless Steel
M — Monel
S — 316 Stainless Steel
X — Special to application

The third letter determines the material of the stator. It identifies only the stator material and not that of the tube in which the stator is placed.

B — EPDM 300, 70 Durometer
C — Buna "N" 103, 50 Durometer
D — Tool Steel
E — Buna "N" 110, 70 Durometer
F — Viton 500, 75 Durometer
G — 416 Stainless Steel
H — Hastelloy "C"
J — 17-4 PH Stainless Steel
K — Hypalon 800, 70 Durometer
M — Buna "N" 100M, 70 Durometer
P — Thiokol 70 Durometer
Q — Buna "N" 100, 700 Durometer
R — Natural Rubber 200, 55 Durometer
T — Teflon 15% glass
U — Urethane 70 Durometer
X — Special to application
Z — Buna "N" 150, 70 Durometer

Do not order by Reference Number. Use Part Number on page 3.

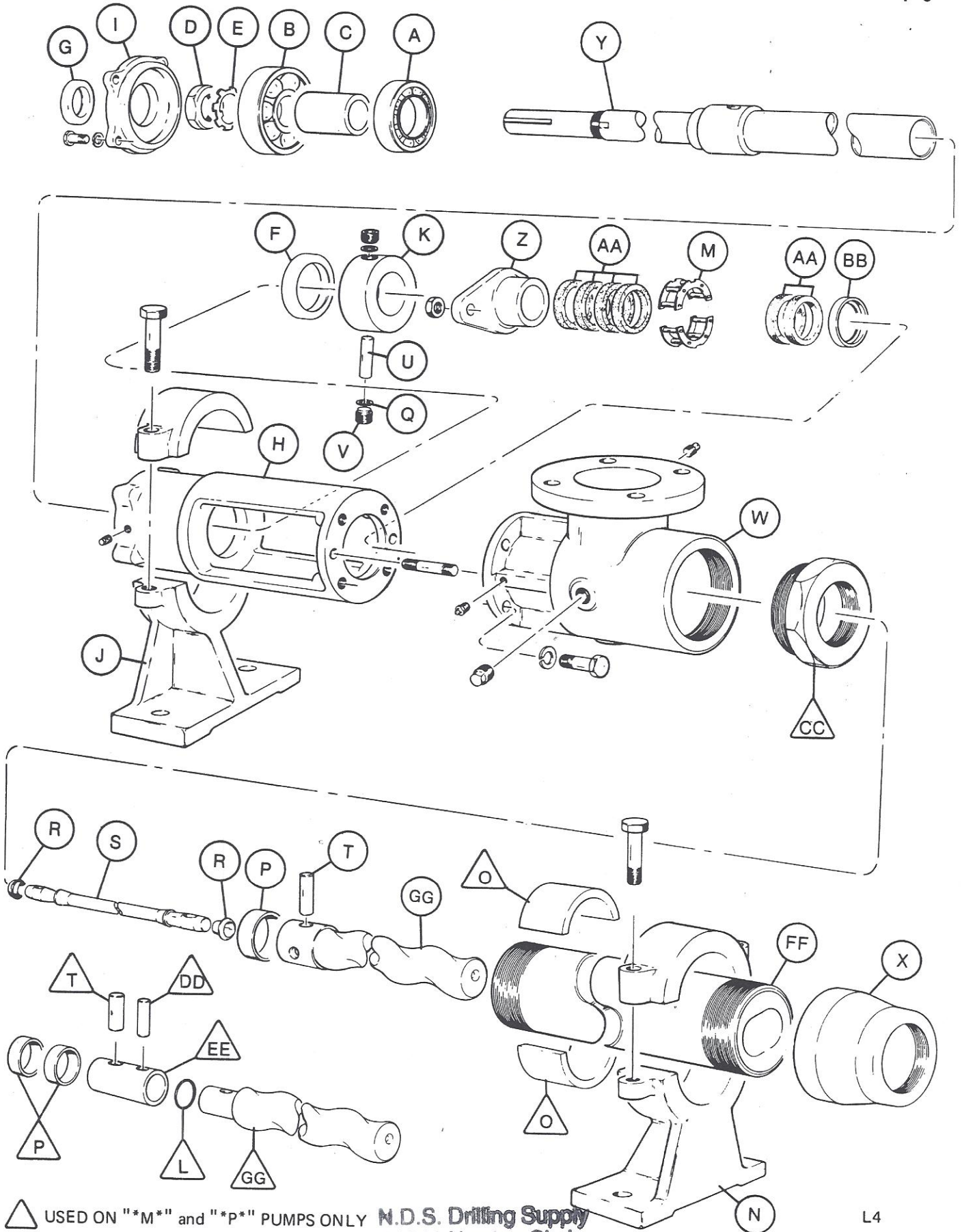

△ USED ON "M" and "P" PUMPS ONLY

N.D.S. Drilling Supply
 26041 Newton Circle
 Eiko, MN 55020
 Phone # 800-637-1940
 Fax # 952-461-3403

L4

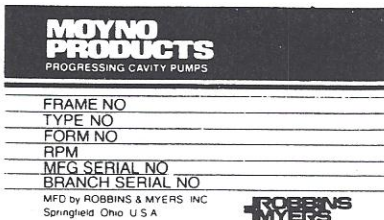

Select type column corresponding to type designation at left.
Order by part number. Refer to frame size to select proper rotor and stator.

REF. NO.	DESCRIPTION	Part No.	Part No.	Part No.	Part No.	Part No.	Part No.
		CDQ	CDD	CSQ	CSG	SSQ	SSG
		CDR	CDG	CSR	CSD	SSR	SST
		CDB	CDT	CSB	CST	SSB	
		CDF		CSF		SSF	
A.	Ball Bearing (Radial)	A04291	A04291	A04291	A04291	A04291	A04291
B.	Ball Bearing (Thrust)	A04301	A04301	A04301	A04301	A04301	A04301
C.	Bearing Spacer	A04331	A04331	A04331	A04331	A04331	A04331
D.	Bearing Lock Nut	A04581	A04581	A04581	A04581	A04581	A04581
E.	Bearing Lock Washer	A04591	A04591	A04591	A04591	A04591	A04591
F.	Grease Seal (Radial)	A04611	A04611	A04611	A04611	A04611	A04611
G.	Grease Seal (Thrust)	A04621	A04621	A04621	A04621	A04621	A04621
	Bearing Kit**	K04291	K04291	K04291	K04291	K04291	K04291
H.	Bearing Housing	A04051	A04051	A04051	A04051	A04051	A04051
I.	Bearing Cover Plate	A04341	A04341	A04341	A04341	A04341	A04341
J.	Pump Support	A04371	A04371	A04371	A04371	A04371	A04371
K.	Shaft Collar	A04491	A04491	A04491	A04491	A04491	A04491
L.	O-Ring 9P2 Only	A04111	--	A04111	--	A04111	--
M.	Lantern Ring	A04571	A04571	A04571	A04571	A04571	A04571
N.	Stator Support 1L4,2L4						
	3L4, 6M3	A04381	A04382	A04381	A04382	A04381	A04382
	3M3, 6P2, 3P2	A04381	A04381	A04381	A04381	A04381	A04381
	9P2	A04383	--	A04383	--	A04383	--
O.	Support Bushing 3M3	A04711	--	A04711	--	A04711	--
	3P2,6P2	A03711	A04711	A03711	A04711	A03711	A04711
P.	Pin Retainer	A04501	A04501	A04501	A04501	A04501	A04501
Q.	Retaining Screw Washer	A04731	A04731	A04731	A04731	A04731	A04731
R.	Connecting Rod Washer	A04531	A04531	A04531	A04531	A04531	A04531
S.	Connecting Rod	B0425D	B0425D	B0425S	B0425S	B0425S	B0425S
T.	Rotor Pin	B0445D	B0445D	B0445S	B0445S	B0445S	B0445S
U.	Shaft Pin	B0446D	B0446D	B0446S	B0446S	B0446S	B0446S
V.	Drive Pin Retainer Screw	B0454D	B0454D	B0454S	B0454S	B0454S	B0454S
	Connecting Rod Kit***	K0425D	K0425D	K0425S	K0425S	K0425S	K0425S
W.	Suction Housing	B04021	B04022	B04021	B04022	B04026	B04027
X.	Reducer 1L4, 2L4, 3L4,	B04091	B04092	B04091	B04092	B04096	B04097
	6M3	B03092	B04092	B03091	B04092	B03096	B04097
	3M3	B03091	B03092	B03091	B03092	B03096	B03097
	3P2, 6P2	B02091	B02092	B02092	B02092	B02096	B02097
	9P2	B03091	--	B03091	--	B03096	--
Y.	Drive Shaft +	B04261	B04261		B04266	B04266	B04266
Z.	Packing Gland	B0441D	B0441D	B0441S	B0441S	B0441S	B0441S
AA.	Packing +	B04421	B04421	B04425	B04425	B04425	B04425
BB.	Packing Washer	B0465D	B0465D	B0465S	B0465S	B0465S	B0465S
CC.	Adapter Bushing 3M3,9P2	B03512	B04511	B03512	B04511	B04516	B03517
	3P2, 6P2	B04512	B03512	B04512	B03512	B04517	B03517
DD.	Rotor Head Pin						
	3M3, 6P2, 9P2	B04471	B04471	B04472	B04472	B04472	B04472
	3P2	B04473	B04473	B04474	B04474	B04474	B04474
	9P2	B0445D	B0445D	B0445S	B0445S	B0445S	B0445S
EE.	Rotor Head 3M3, 6P2	B04321	B04321	B04322	B04322	B04322	B04322
	3P2	B04323	B04323	B04324	B04324	B04324	B04324
	9P2	B04325	B04325	B04326	B04326	B04326	B04326
FF.	Stator Frame 1L4	C4104*	C4104*	C4104*	C4104*	C5104*	C5104*
	Frame 2L4	C4204*	C4204*	C4204*	C4204*	C5204*	C5204*
	Frame 3L4	C4304*	C4304*	C4304*	C4304*	C5304*	C5304*
	Frame 3M3	C4303*	C4303*	C4303*	C4303*	C5303*	C5303*
	Frame 6M3	C4603*	C4603*	C4603*	C4603*	C5603*	C5603*
	Frame 3P2	C4303*	C4303*	C4302*	C4302*	C5302*	C5302*
	Frame 6P2	C4602*	C4602*	C4602*	C4602*	C5602*	C5602*
	Frame 9P2	C4902*	--	C4902*	--	C5902*	--
GG.	Rotor Frame 1L4 +	C71041	C71041	C81041	C81041	C81041	C81041
	Frame 2L4 +	C72041	C72041	C82041	C82041	C82041	C82041
	Frame 3L4 +	C73041	C73041	C83041	C83041	C83041	C83041
	Frame 3M3 +	C73031	C73031	C83031	C83031	C83031	C83031
	Frame 6M3 +	C76031	C76031	C86031	C86031	C86031	C86031
	Frame 3P2 +	C73021	C73021	C83021	C83021	C83021	C83021
	Frame 6P2 +	C76021	C76021	C86021	C96021	C86021	C86021
	Frame 9P2 +	C79021	--	C89021	--	C89021	--

*Add third letter of type designation to complete Part No.

**Bearing Kit includes Items A thru G.

EX: Type CDQ pump Add Q To basic number of stator.

***Connecting Rod Kit includes Items Q thru V. + See pages 5 - 6 for variations

A typical type designation such as CDQ would result in the following:

- C = Cast Iron Suction Housing
- D = Hardened Steel Internals including drive shaft, pins, connecting rod, rotor, and other minor metallic parts in contact with the material being pumped
- Q = Buna N Synthetic Rubber Stator (70 durometer)

Also included on the nameplate is the three-character trim code designation. This only appears on pumps which have semi-standard or special construction. The first letter identifies sealing variations, the second character identifies internal variations, and the third letter identifies rotor variations.

On page 5 of this manual are variations available for modifying pumps to meet specialized pumping conditions. If the trim code of your pump is other than "AAA", contact your nearest Moyno representative for clarification. Do not use any variation unless you have determined that it is compatible with your application.

INSTRUCTIONS FOR DISASSEMBLY AND ASSEMBLY Frames 1L4, 2L4, 3L4, 3M3, 6M3, 3P2, 6P2, 9P2

Disassembly Procedure

1. Disconnect the power source.
 2. Close the suction and discharge valves to isolate the pump from the line.
 3. Turn off flush water to packing or rotary seal if used.
 4. Remove drain plug in suction housing to drain away any fluid remaining in pump.
 5. Place a support block under suction housing in area of drain plug. Wooden blocks are sufficient. The purpose is to prevent undue stress on pump support when pump is disassembled.
 6. Disconnect piping from stator end of pump.
 7. **Stator Removal** - With pipe wrench or strap wrench remove discharge reducer (X). Remove cap of stator support and with strap wrench or pipe wrench, unscrew the stator (FF) from the suction housing. Pull Stator off the rotor.
 8. **Rotor Removal** - The rotor (GG) is removed with the connecting rod (S) and rotor pin (T) as a unit. Removal of the unit is accomplished by removing the two drive pin retaining screws (V) located in the shaft collar (K). This step reveals the shaft drive pin (U) which is removed by driving the pin from the drive shaft (Y) with a small punch or drift pin. Slide the shaft collar toward the packing gland (Z) and remove the retaining screw washers (Q) from each side of the drive shaft. The rotor and connecting rod can now be removed by pulling them from the pump. To disassemble, clamp the connecting rod (S) by its mid-section in a vise and, with a drift pin, drive the pin retainer (P) from the head of the rotor. The rotor pin (T) can now be removed from the rotor freeing the connecting rod. Remove the connecting rod washers (R) if present.
- On most "M" and "P" frame pumps a detachable rotor head (EE) is present. On these pumps a second pin retainer (P) is present to retain the rotor head pin (DD). An "O" ring (L) is present only on frame 9P2 pumps.
9. To remove packing (AA), remove nuts holding packing gland (Z). Slip packing gland from studs, remove packing rings, lantern ring (M), and remaining packing rings. Packing rings can be removed with a standard packing puller. Note: If step 10 is to be performed, it should precede step 9 as packing can then be removed by freeing packing gland and driving packing,

lantern ring, and packing washer (BB) from housing using a small rod. Rod should enter where stator screws into suction housing. Place rod on packing washer and tap. Entire set should easily exit from opposite end of stuffing box.

10. **Drive Shaft & Bearing Removal** - With rotor removed it is now possible to remove the drive shaft and bearings as a sub-assembly. Remove the four cap screws holding the bearing cover plate (I) and slip from shaft. Insert a bar or rod into the hollow end of drive shaft (Y) where it enters the suction cavity. By tapping on the rod the entire assembly will be forced from the bearing housing.

To disassemble, remove bearing lock nut (D) and bearing lock washer (E). Using an arbor press remove radial bearing (A), bearing spacer (C), and thrust bearing (B). Apply pressure to inner race only.

When replacing drive shaft and/or bearings, it is recommended that both grease seals be replaced. Grease seals are pressed into the bearing housing and bearing cover plate.

Assembly Procedure

Moyno pumps are reassembled in the reverse order of disassembly with special notes as outlined below:

1. Always replace all old washers, "O" rings, and packing. We also recommend replacing grease seals when new bearings are installed.
2. **Bearing Shaft Assembly** - When installing new bearings, make sure that they are seated against the shoulder on the shaft. Replace bearing lock washer and bearing lock nut. Tighten bearing lock nut securely. Bend tab down onto lock nut to prevent loosening of nut.
Make sure that the shaft collar, packing gland, and packing washer are installed on the drive shaft as the hollow end emerges in the bearing housing and approaches the stuffing box area.
When replacing the bearing cover plate, tighten all cap screws evenly to prevent damage to the bearing cover plate and thrust grease seal.
Do not over-lubricate bearings. (See Maintenance)
3. When installing the connecting rod, make sure that the hole in the rod is aligned with the holes in the drive shaft and shaft collar **before** inserting the pin. Always use retaining screw washers and make sure that the hollowed end of the retaining screw fits over the end of the shaft pin to ensure a tight fit. Retaining screws must seat on retaining screw washers and **not** on pin.
4. When replacing packing, insert two rings on the shaft, the lantern ring, and then four more rings. This will allow the lantern ring to line up with the grease fitting on the stuffing box. **Make sure you stagger the ends of the packing rings.**
When installing the new packing, you may find that all but one ring will go on the drive shaft. When the pump has run for a short time and the new packing is compressed, this final ring can be installed.
5. When installing the stator on the rotor, it is best to lubricate the rotor with water (or a lubricant compatible with the rubber in the stator) to allow the stator to slip on easier. (Grease or oil is not compatible with type "R" or "B" stators.)
When replacing the stator, always tighten it with the pipe wrench on the end of the stator nearest the suction housing. This will prevent it from binding and damaging the threads.
If your stator has a stainless steel sleeve, use a teflon tape or similar material on the threads before replacing -- on all stators with a carbon steel sleeve, use pipe dope.

6. **Caution: Dry operation is harmful to the pump. Always fill the pump with fluid to be handled prior to start up. Check any valves in discharge line to determine that no restrictions exist.**

MAINTENANCE

The Moyno pump has been designed for a minimum of maintenance, the extent of which is routine lubrication and adjustment of packing and infrequent lubrication of the bearings. The pump is one of the easiest to work on in that the main elements are very accessible and require few tools to disassemble.

Packing

The Moyno pump is normally furnished with die formed packing. The packing may be either grease lubricated through a grease fitting in the stuffing box or have plumbing connected to the housing to allow a water flush. (See Water Flush of Packing)

Packing gland adjusting nuts should be evenly adjusted so they are little more than finger tight. Over-tightening of the packing gland may result in premature packing failure and possible damage to the shaft and gland. When the packing is new, frequent minor adjustments are recommended for the first few hours of operation in order to compress and seat the packing. Greasing the packing often but with limited quantities of grease is the best practice. This can be done through a grease fitting which leads to a lantern ring in the mid-section of the packing. Do not use a one-piece spiral wrap of packing.

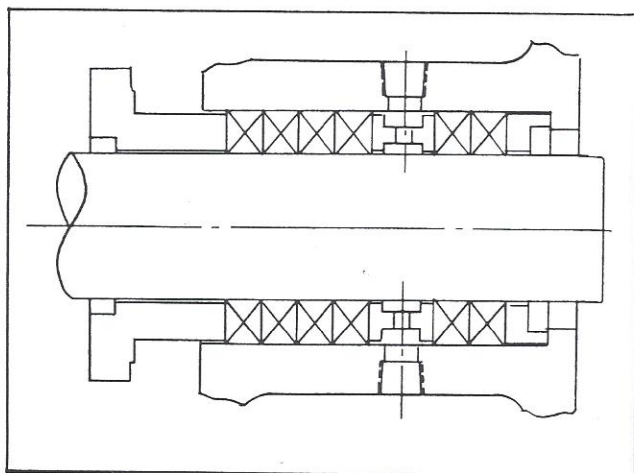

Cross section of stuffing box

Water Flush of Packing

When the material being pumped is abrasive in nature, it may be advantageous to flush the packing to prevent leakage under packing and excessive shaft wear.

Clean water can be injected through a 1/8" NPT tapped hole that normally houses the grease fitting for lubricating the packing. The water can be permitted to leak axially along the shaft in either direction or can be removed from the second tapped hole in the stuffing box. In both cases, the discharge from the stuffing box should be throttled slightly to maintain 10-15 PSI higher pressure in the stuffing box than is present in the suction housing.

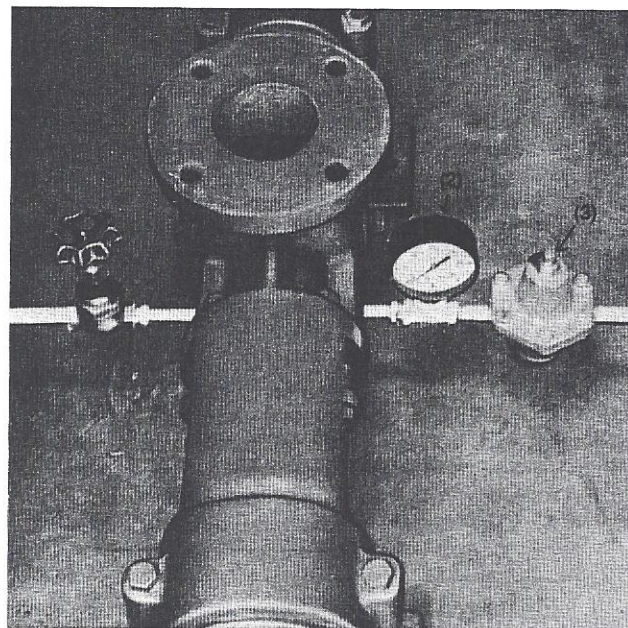

Typical water Flush to packing

This is a basic arrangement, other variations can be used.
(1) Throttling Valve (2) Pressure Gauge (3) Pressure Regulating Valve

Bearings

The Moyno pump is equipped with ball bearings in the drive end size L2 through L10. The bearings are lubricated at the factory and do not need additional lubrication for at least 1500 hours of normal operation.

When relubricating the bearings, the bearing-shaft assembly should be removed (See Disassembly instructions) and cleaned of old grease. Add only enough grease to fill the area between the bearings 1/3 full. Add a few drops of oil to bearing seals before reassembling. It is normal for bearings to run warm to the touch for the first few hours of operation.

Any type of Ep Lithium soap base grease is satisfactory for bearing lubrication. The use of Sodium or Calcium base grease is not recommended.

The following is a partial listing of approved bearing lubricants:

Dow Corning	DC 33
Keystone Lubricating Co.	Keystone #89
Texaco	Regal AFB2
Shell Oil Co.	Cyprina #3
Humble Oil & Refining Co.	Beacon 325
American Oil Co.	Supermil Grease #A72832
Mobil	EP1
Shell Oil Co.	Alvania #2

VARIATIONS OF STANDARD PARTS

Following are variations available for modifying pumps to meet specialized pumping conditions. If the trim code of your pump is other than "AAA," contact your nearest Moyno representative for clarification. Do not modify your pump with any variation unless you have determined that it is compatible with your application.

The three-character trim code is designed as follows. The first character identifies any sealing variations, the second character identifies any internal variations, and the third character identifies any rotor variations.

Sealing Variation ————
Internal Variation ———— A A A
Rotor Variation ————

The trim code "AAA" represents a pump with standard features. Deviations from standard are to be indicated by changing the appropriate character from the choices listed. When two or more letters are combined, dashes are used to separate the three areas of the trim code for clarity.

SEALING VARIATIONS

- A — BRAIDED TEFLON & GRAPHITE PACKING, (Black) Standard to all lines except Quick Disassembly pumps. Optional on Quick Disassembly pumps.
- C — BRAIDED TEFLON PACKING, (White) Optional packing on all lines.
- D — DOUBLE MECHANICAL SEAL, Optional on all lines. Not offered on #2 "L" frame.
- F — BRAIDED TEFLON FOOD GRADE PACKING, (White) Standard on all Quick Disassembly pumps. Optional on all other lines.
- G — 100% GRAPHITE PACKING, (Gray) Optional to all lines.
- S — SINGLE MECHANICAL SEAL, Optional on all lines.
- W — WATER FLUSH, Optional on all lines.
- X — Special to application.

INTERNAL VARIATIONS

- A — Standard plated shaft
- B — Non-plated shaft
- C — Solid drive shaft configuration
- D — Grit seal, for "L" frame only
- E — Extension tube with extended auger
- F — Extended drive shaft (for back stop or large pulley)
- G — Ceramic coating
- S — Shaft sleeve
- X — Special to application

ROTOR VARIATIONS

- A — Standard size with chrome plating
- B — Non-plated (no plating)
- C — Standard undersize
- E — Standard oversize
- F — Counter clockwise rotation (Centennial line only)
- G — Ceramic coating
- X — Special to application

N.D.S. Drilling Supply
26041 Newton Circle
Elko, MN 55020
Phone # 800-637-1940
Fax # 952-461-3403

ROTORS identified on parts listing are standard size with hard-chrome plated surface. Other variations of rotor size and finish may be ordered by selecting the standard rotor part number and changing the last digit of the rotor number as follows:

- 2 = Standard size, non-plated
- 3 = Undersize, chrome-plated
- 4 = Undersize, non-plated
- 5 = Oversize, chrome-plated

Do not change rotor sizes without consulting your local Moyno Sales Office. These variations are used for certain specialized pumping conditions only.

PACKING VARIATIONS listed are common to most type designations. Others may be specified by changing the last digit to the following:

- 1 = Standard on all type CDQ pumps
- 3 = Standard on all type CDR & SSR pumps
- 5 = Standard on all type SSQ pumps
- 7 = Optional--Solid Braided Teflon
- 8 = Optional--Teflon impregnated white asbestos

DRIVE SHAFTS shown have hard-chrome plating on the packing wear area. If non-plated drive shafts are required, select the standard part number and change the last digit to next higher number. Example: B04261 to B04262.

L4 STANDARD HARDWARE

ITEM	SIZE	# REQ.
Lock Washer		4
Packing Gland Stud	2 1/2L X 3/8D-16	2
Packing Gland Bolt Nut	2 1/2L X 3/8D-16	2
Nut	1 1/2L X 3/8D-16	2
Stator & Pump Support Screws	1 3/4L X 3/8D-16	4
Suction Housing Drain Plug	1/2NPT	3
Pipe Plug	1/8NPT	2
Grease Fitting	1/8NPT	1
Hex Key	5/16	1

RECOMMENDED SPARE PARTS

The Moyno pump has been designed and built with all wearable parts replaceable. A recommended inventory of spare parts is dependent upon the application and importance of continued operation.

For the shortest possible down time, we recommend the following parts be stocked:

- 1 - Rotor
- 1 - Stator
- 1 - Connecting Rod Kit

The above is only a suggested list. For further assistance in determining what you'll need for your application, contact your Moyno representative.