

[NDS Home Page Hyperlink](#)

NDS Drilling Supply
26041 Newton Circle
Elko New Market, MN 55020
sales@ndsdrillingsupply.com
1-800-637-1940
(952) 461-3400
(952) 461-3403 (fax)

Service Manual

SM-225
#1015958

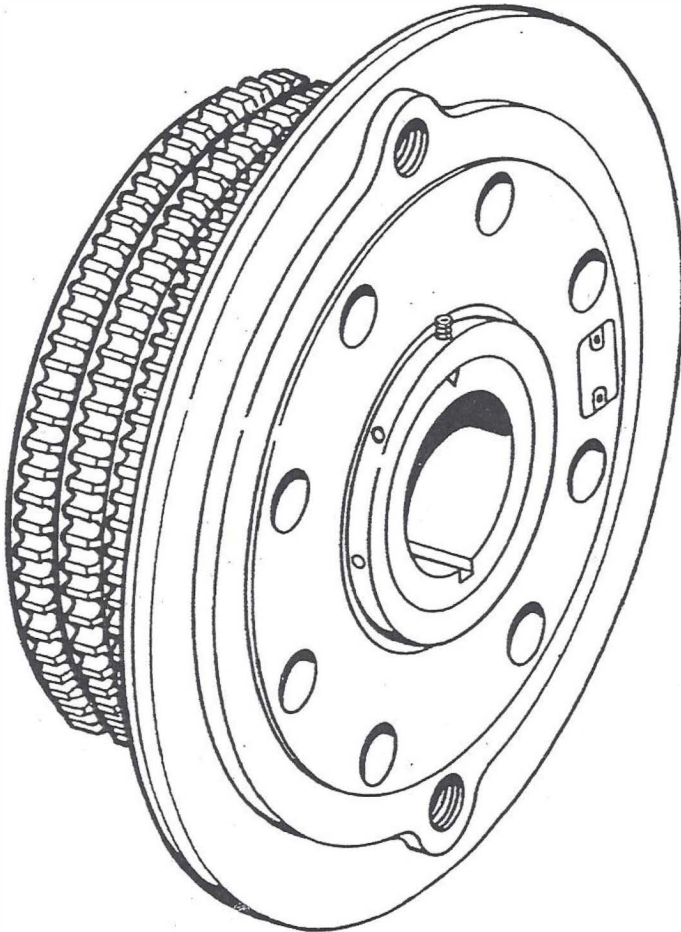

MODELS

PO-108 PO-310

PO-208 PO-111

PO-308 PO-211

PO-110 PO-311

PO-210

**AIR OPERATED
CLUTCHES**

TWIN DISC

INCORPORATED

Administrative Offices - Racine, Wisconsin



SERVICE MANUAL

SM-225

#1015958

MODELS PO-108, PO-208, PO-308

PO-110, PO-210, PO-310

PO-111, PO-211, PO-311

AIR CLUTCHES

ORIGINAL ISSUE — April 1979
Revision A, April 1982
Revision B, January 1998

N.D.S. Drilling Supply
26041 Newton Circle
Elko, MN 55020
Phone # 800-637-1940
Fax # 952-461-3403

Twin Disc, Incorporated
1328 Racine Street
Racine, Wisconsin 53403
U.S.A.

Printed in U.S.A.

TABLE OF CONTENTS

Section 1.	INTRODUCTION	1-1
Section 2.	DESCRIPTION AND SPECIFICATIONS.....	2-1
Section 3.	OPERATION	3-1
Section 4.	PREVENTIVE MAINTENANCE.....	4-1
Section 5.	TROUBLE SHOOTING.....	5-1
Section 6.	REMOVAL AND UNIT DISASSEMBLY.....	6-1
Section 7.	CLEANING AND INSPECTION.....	7-1
Section 8.	SUBASSEMBLIES.....	8-1
Section 9.	UNIT ASSEMBLY AND INSTALLATION.....	9-1
Section 10.	ACCESSORIES AND OPTIONAL EQUIPMENT.....	10-1
Section 11.	SPECIAL TOOLS.....	11-1
Section 12.	DRAWINGS AND DATA.....	12-1

N.D.S. Drilling Supply
26041 Newton Circle
Elko, MN 55020
Phone # 800-637-1940
Fax # 952-461-3403



TWIN DISC, INCORPORATED EXCLUSIVE LIMITED WARRANTY GENERAL UNITS

- A. Twin Disc, Incorporated warrants all assembled products and parts, (except component products or parts on which written warranties issued by the respective manufacturers thereof are furnished to the original customer, as to which Twin Disc, Incorporated makes no warranty and assumes no liability) against defective materials or workmanship for a period of twenty-four (24) months from the date of original shipment by Twin Disc, Incorporated to the original customer, but not to exceed twelve (12) months of service, whichever occurs first. This is the only warranty made by Twin Disc, Incorporated and is in lieu of any and all other warranties, express or implied, including the warranties of merchantability or fitness for a particular purpose and no other warranties are implied or intended to be given by Twin Disc, Incorporated.

The original customer does not rely upon any tests or inspections by Twin Disc, Incorporated or on Twin Disc, Incorporated's application engineering.

- B. The exclusive remedy provided by Twin Disc, Incorporated whether arising out of warranty within the applicable warranty period as specified, or otherwise (including tort liability), shall at the sole option of Twin Disc, Incorporated be either the repair or replacement of any Twin Disc, Incorporated part or product found by Twin Disc, Incorporated to be defective and the labor to perform that work and to remove and reinstall (or equivalent credit). In this context, labor is defined as the flat rate labor hours established by Twin Disc, Incorporated in the published Twin Disc Flat Rate Schedule, required to remove, disassemble, inspect, repair, reassemble, reinstall and test the Twin Disc, Incorporated product only. Under no circumstances, including a failure of the exclusive remedy, shall Twin Disc, Incorporated be liable for economic loss, consequential, incidental or punitive damages. The above warranty and remedy are subject to the following terms and conditions:

1. Complete parts or products upon request must be returned transportation prepaid and also the claims submitted to Twin Disc, Incorporated within sixty (60) days after completion of the in warranty repair.
2. The warranty is void if, in the opinion of Twin Disc, Incorporated, the failure of the part or product resulted from abuse, neglect, improper maintenance or accident.
3. The warranty is void if any modifications are made to any product or part without the prior written consent of Twin Disc, Incorporated.
4. The warranty is void unless the product or part is properly transported, stored and cared for from the date of shipment to the date placed in service.
5. The warranty is void unless the product or part is properly installed and maintained within the rated capacity of the product or part with installations properly engineered and in accordance with the practices, methods and instructions approved or provided by Twin Disc, Incorporated.
6. The warranty is void unless all required replacement parts or products are of Twin Disc origin or equal, and otherwise identical with components of the original equipment. Replacement parts or products not of Twin Disc origin are not warranted by Twin Disc, Incorporated.

- C. As consideration for this warranty, the original customer and subsequent purchaser agree to indemnify and hold Twin Disc, Incorporated harmless from and against all and any loss, liability, damages or expenses for injury to persons or property, including without limitation, the original customer's and subsequent purchaser's employees and property, due to their acts or omissions or the acts or omissions of their agents, and employees in the installation, transportation, maintenance, use and operation of said equipment.
- D. Only a Twin Disc, Incorporated authorized factory representative shall have authority to assume any cost or expense in the service, repair or replacement of any part or product within the warranty period, except when such cost or expense is authorized in advance in writing by Twin Disc, Incorporated.
- E. Twin Disc, Incorporated reserves the right to improve the product through changes in design or materials without being obligated to incorporate such changes in products of prior manufacture. The original customer and subsequent purchasers will not use any such changes as evidence of insufficiency or inadequacy of prior designs or materials.
- F. If failure occurs within the warranty period, and constitutes a breach of warranty, repair or replacement parts will be furnished on a no-charge basis and these parts will be covered by the remainder of the unexpired warranty which remains in effect on the complete unit.

Section 1.

INTRODUCTION

N.D.S. Drilling Supply
26041 Newton Circle
Elko, MN 55020
Phone # 800-637-1940
Fax # 952-461-3403

GENERAL INFORMATION.

Scope.

This publication provides the information necessary for the operation and maintenance of the Twin Disc, Incorporated equipment specified on the cover of this manual. Specific engineering details and performance characteristics can be obtained from the Service Engineering Department of Twin Disc, Incorporated, Racine, Wisconsin, U.S.A.

Operation and maintenance personnel responsible for this equipment should have this manual at their disposal and be familiar with its contents. Applying the information in the manual will result in consistent performance from the unit and help reduce downtime.

Special Tools.

Engineering drawings are included for the fabrication of special tools that should be used during disassembly and assembly of a unit. Repair of this equipment should not be attempted without special tools. Twin Disc does not manufacture these tools for general use.

RENEWAL PARTS AND KITS.

Parts Lists.

Illustrations with complete parts listings are provided in appropriate sections of the manual to facilitate ordering spare or renewal parts and kits.

Ordering Parts.

Renewal Parts and Service Parts Kits, may be obtained from an authorized Twin Disc distributor or service dealer. They are listed under POWER TRANSMISSION EQUIPMENT in the Yellow Pages of most metropolitan telephone directories.

NOTE

Do NOT use planographs included in this manual for ordering parts. Parts must be ordered from the bill of material (formally specifications). Bill of material numbers are stamped on the unit's nameplate.

If the bill of material sheet from which part numbers are obtained is unavailable, proceed as follows:

1. Provide the figure number of the illustration containing the part, the item number of the part, the description of the part, and the quantity required.
2. Do not use the word "complete", but state exactly each item wanted.
3. Do not designate the quantity by "sets", but specify the part required.
4. Specify the model, bill of material (formally specifications), and serial number of the unit involved. These numbers are stamped on the unit's nameplate.

Parts Shipment.

Furnish the complete shipping destination and postal address. All parts shipments made from the factory will be F.O.B. factory location, U.S.A. State specifically whether the parts are to be shipped by freight, express, etc. If shipping instructions are not specified on the order, the equipment will be shipped the best way, considering time and expense. Twin Disc, Incorporated will not be responsible for any charges incurred by this procedure.

Twin Disc, Incorporated, having stipulated the bill of materials (formally specifications) number on the unit's nameplate, absolves itself of any responsibility resulting from any external, internal, or installation changes made in the field without the express written approval of Twin Disc. All returned parts, new or old, emanating from any of the above stated changes will not be accepted for credit. Furthermore, any equipment which has been subjected to such changes will not be covered by a Twin Disc Warranty.

PREVENTIVE MAINTENANCE-TROUBLE SHOOTING.

Frequent reference to the information provided in this manual regarding daily operation and limitations of this equipment will assist in obtaining trouble free operation. Schedules are provided for the recommended maintenance of the equipment, and if observed, minimum repairs, aside from normal wear, will result.

In the event a malfunction does occur, a trouble shooting table is provided to help identify the problem area, and list information that will help determine the extent of the repairs necessary to get a unit back into operation.

LIFTING BOLT HOLES.

Most Twin Disc products have provisions for attaching lifting bolts. The holes provided are always of adequate size and number to safely lift the Twin Disc product.

CAUTION

These lifting points must not be used to lift the complete power unit. Lifting excessive loads at these points could cause failure at the lift point (or points) and result in damage or personal injury.

CAUTION

Select lifting eyebolts to obtain maximum thread engagement with bolt shoulder tight against housing. Bolts should be near but should not contact bottom of bolt hole.

SAFETY.

General.

Safe operating practices should be employed by all personnel servicing this unit. Twin Disc, Incorporated will not be responsible for personal injury resulting from careless use of hand tools, lifting equipment, power tools, or unaccepted maintenance/working practices.

Important Safety Notice.

Because of the possible danger to person(s) or property from accidents which may result from the use of

manufactured products, it is important that correct procedures be followed. Products must be used in accordance with the engineering information specified. Proper installation, maintenance, and operation procedures must be observed. Inspection should be made as necessary to assure safe operations under prevailing conditions. Proper guards and other suitable safety devices or procedures that may be desirable or specified in safety codes should be provided. These devices are neither provided by Twin Disc, Incorporated nor are they the responsibility of Twin Disc, Incorporated.

SOURCE OF SERVICE INFORMATION.

Each series of maintenance manuals issued by Twin Disc, Incorporated is current at the time of printing. When required, changes are made to reflect advancing technology and improvements in state of the art.

Individual product service bulletins are issued to provide the field with immediate notice of new service information. These service bulletins are distributed to all the Twin Disc distributorships throughout the United States and in many foreign countries.

For the latest service information on Twin Disc products, contact a Twin Disc Distributor, or write to the Service Engineering Department, Twin Disc, Incorporated, Racine, Wisconsin, U.S.A.

WARRANTY

Equipment for which this manual was written has a limited warranty. For details of the warranty, contact any Twin Disc distributor, service dealer, or the Warranty Administration Department, Twin Disc, Incorporated, Racine, Wisconsin, U.S.A.

**N.D.S. Drilling Supply
26041 Newton Circle
Elko, MN 55020
Phone # 800-637-1940
Fax # 952-461-3403**

Section 2

DESCRIPTION AND SPECIFICATIONS

GENERAL.

Identification

The letters and numbers in the model designation for the products described in this manual, identify as follows:

Example: PO-311

PO = Pneumatically operated

3 = Three clutch driving plate

11 = Diameter of clutch driving plates in even inches.

Description

Models PO-108, PO-208, PO-308, PO-110, PO-210, PO-310, PO-111, PO-211, and PO-311 air clutches are one, two and three plate air-actuated, spring-released axial clutches. These models are very similar with the major difference being the diameter and number of driving plates.

As an example, PO-311 is described as follows:

Torque is transmitted from the power source to the driving ring (Figure 9-1,1) or drive spider to

which the driving plates (4, 6, and 8) are meshed. During clutch engagement, the pressure plate (9) clamps the driving plates and center plate (2). The hub and back plate, spline connected to the center plates, transmits the torque through its hub-and-shaft key to the output shaft. The drive through is on a common center axis with the input.

Air cooling passages are provided from the plate area through and around the release spring chambers through cored holes in the front cover plate (13).

Synthetic rubber, molded on a nylon fabric, comprises the material for the diaphragm (12). The note "assemble with this side up" is molded on the diaphragm to insure proper assembly.

OPERATING SPECIFICATIONS.

Maximum Allowable Speed.

WARNING

These speeds are not to be exceeded by more than 8% including governor overrun.

Model	Maximum Allowable R.P.M.				Torque Lb. Ft at 130 PSI)		H.P. Rating	
	Cast Iron Driving Ring		Steel or Mod. Iron Driving Ring					
	Solid Dr. Plts.	Split Dr. Plts.	Solid Dr. Plts.	Split Dr. Plts.	Slip	Working	Normal Duty	Heavy Duty
PO 108	3600	3050	4750	4020	390	292	45	30
PO 208	4200	3650	(4850)	(4850)	780	585	65	40
PO 308	4250	3650	(4850)	(4850)	1170	877	85	50
PO 110	3100	2650	3930	3500	660	495	67	50
PO 210	3600	2900	(4100)	(4100)	1320	990	100	65
PO 310	3650	2950	(4100)	(4100)	1980	1485	135	80
PO 111	2850	2200	3550	3200	1160	870	85	60
PO 211	2850	2200	3550	3160	2320	1740	130	80
PO 311	3250	2720	(3550)	(3550)	3480	2610	175	100

Section 3. OPERATION

CLUTCH OPERATION.

To engage the clutch, air is directed to the diaphragm (Figure 3-1, E) building up pressure behind the diaphragm. The pressure moves insulator plate (F) and pressure plate (G) to the left, clamping driving plates (H) against center

plates (K) and hub-and-back plate (J). Pressure plate movement compresses release springs (C) and the clutch is engaged.

When the air pressure is released from behind the diaphragm, the release springs push the pressure plate (G) back to the released position.

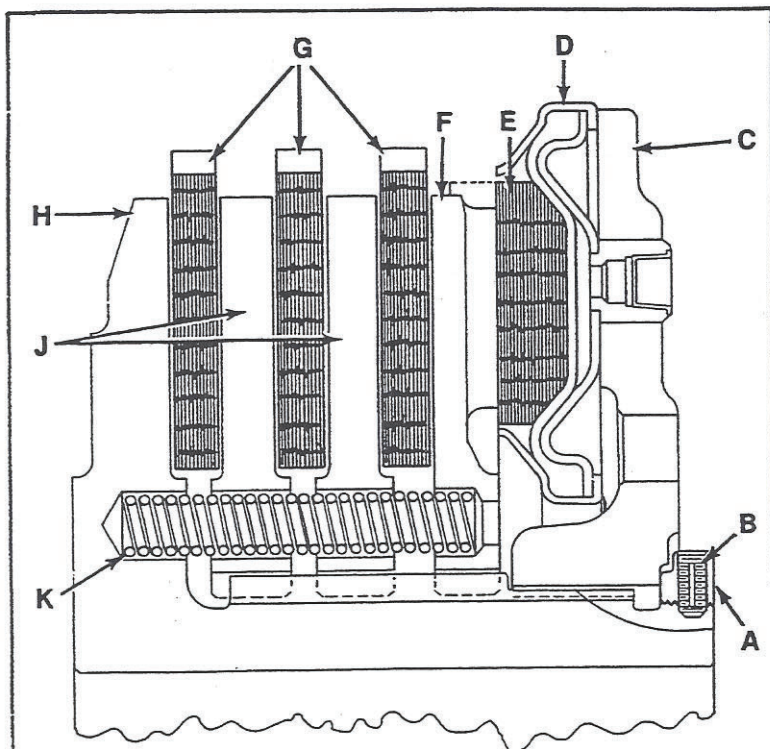

- A. NUT
- B. SETSCREW
- C. FRONT PLATE
- D. DIAPHRAGM
- E. INSULATOR PLATE
- F. PRESSURE PLATE
- G. DRIVING PLATE
- H. HUB-AND-BACK PLATE
- J. CENTER PLATE
- K. RELEASE SPRING

N.D.S. Drilling Supply
26041 Newton Circle
Elko, MN 55020
Phone # 800-637-1940
Fax # 952-461-3403

Figure 3-1. Clutch Operation (Typical Three-plate Clutch).

Section 4.

PREVENTIVE MAINTENANCE

1. Routinely check the following:
 - a. Be sure no dirt or foreign matter has collected in the driving ring or spider which would prevent the driving plates from working freely.
 - b. Check pressure plate and insulator plate for complete release travel.
2. If operating in cold weather, the air lines may be restricted due to freezing of the moisture in the air lines or system. The addition of denatured alcohol or Ethylene Glycol in the air received will eliminate this problem.
3. Avoid the use of all rust inhibitors or commercial anti-freeze.

N.D.S. Drilling Supply
26041 Newton Circle
Elko, MN 55020
Phone # 800-637-1940
Fax # 952-461-3403

Section 5.

TROUBLE SHOOTING

CLUTCH SLIPPAGE.

NOTE

Maximum allowable travel of insulator plate with the clutch engaged (See Figure 5-1), indicates the clutch driving plates are worn and should be replaced.

1. Air pressure at the clutch must be 60-130 psi depending on the amount of torque being transmitted. Put a tee at the point where the air enters the Deublin seal assembly to take this reading.
2. Inspect the entire air line installation for any restrictions or leaks which could decrease the air supply to the clutch.
3. Check the three-way control valve for full opening.
4. Carefully inspect the clutch for possible air leakage at the diaphragm.
5. If operating in cold weather, the air lines may be restricted due to freezing of the moisture in

the air lines or system. The addition of denatured alcohol or Ethylene Glycol in the air system will eliminate moisture freezing. Avoid the use of all rust inhibitors or commercial anti-freeze.

6. Check for grease on the clutch plates. Disassemble and clean the clutch plates if they are greasy.

CLUTCH OVERHEATING.

1. Check all points listed previously under "Clutch Slippage".
2. Check alignment as described in Section 9. If misalignment exists, the clutch may not be completely disengaging.
3. Be sure no dirt or foreign matter has collected in the driving ring or spider which would prevent the driving plates from operating freely.
4. Check the pressure plate and insulator plate for complete release travel.

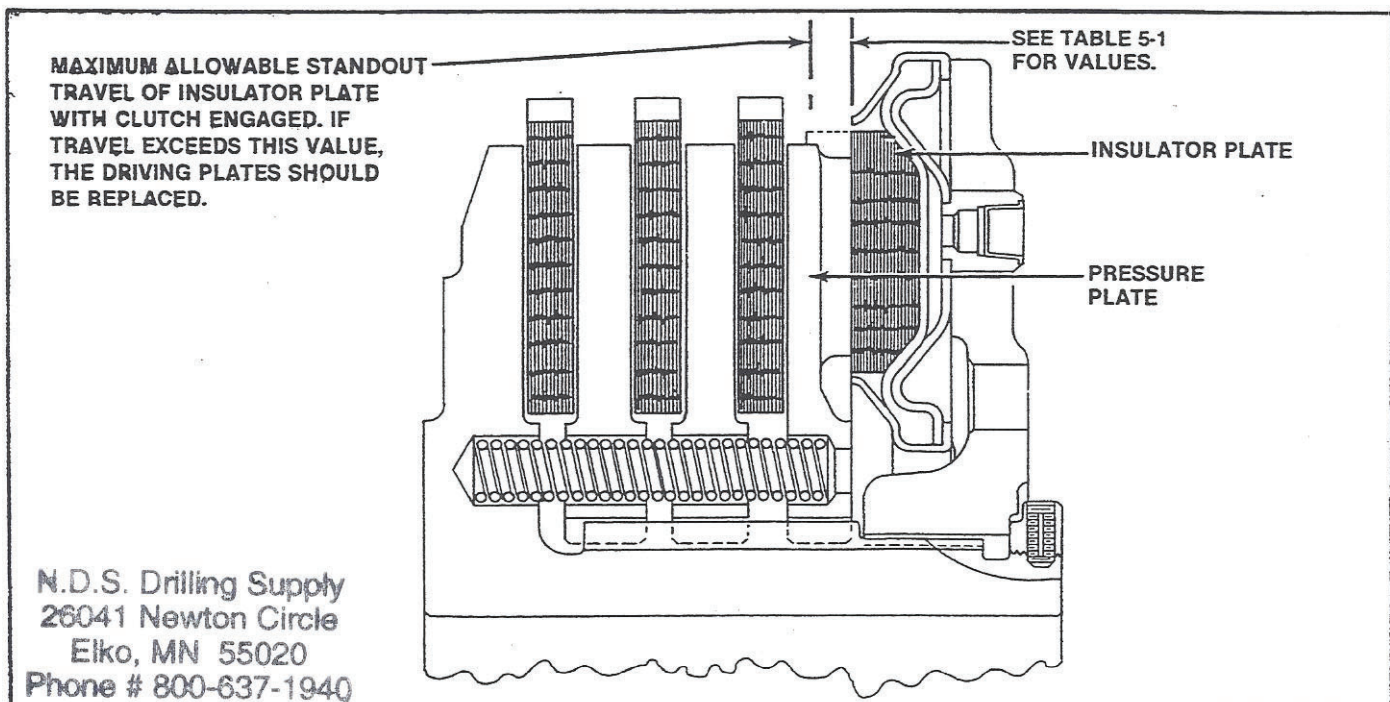

Figure 5-1. Clutch Plate Wear Limits.

**TABLE 5-1. MAXIMUM ALLOWABLE STAND-
OUT TRAVEL**

PO CLUTCH	MAX. ALLOWABLE STANDOUT TRAVEL
0.23	108
0.39	208
0.45	308
0.21	110
0.37	210
0.45	310
0.21	111
0.37	211
0.45	311

N.D.S. Drilling Supply
26041 Newton Circle
Elko, MN 55020
Phone # 800-637-1940
Fax # 952-461-3403

Section 6.

REMOVAL AND UNIT DISASSEMBLY

GENERAL.

See OEM Manual for removal instructions.

NOTE

Wear on the clutch driving plates is determined by measuring the travel of the insulator plate with the clutch engaged (See Figure 5-1). This is measured before disassembly. If wear exceeds allowable limits, replace the driving plates. See Table 5-1.

Using suitable lifting equipment, place the clutch on a working surface, hub and back plate down, and disassemble the clutch as follows:

DISASSEMBLY.

NOTE

Since the PO clutches discussed in this manual are so similar, PO-311 was selected for discussion of disassembly and assembly. The procedure can be readily adapted to any of the clutches discussed in this manual.

1. Place the clutch on a working surface, hub-and-back plate (Figure 9-11, 2) down.

2. Unscrew the hex-socket-head setscrew (15) from the special nut (14) until the nut is free to turn.

3. Remove the special nut (14) from the hub-and-back plate. Use a spanner or chain wrench.

4. Remove the front cover plate (13) and diaphragm assembly (12) from the insulator plate (11).

5. Remove the insulator and pressure plate assembly (11 and 9) from the hub-and-back plate. Pry the insulator plate from the pressure plate only if replacement of the parts is necessary. Six roll pins (10) hold the insulator plate to the pressure plate. Remove the rollpins only if replacement of the parts is necessary.

6. Remove the six release springs (3) from the hub-and-back plate.

7. Remove the three driving plates (4, 6 and 8) and two center plates (5 and 7) from the hub-and-back plate (2).

8. Remove the nameplate (16) from the front cover plate (13) only if replacement of the parts is necessary. Remove the nameplate by prying the two drive screws (17) from the front cover plate. The specification number of the clutch is found on this nameplate.

N.D.S. Drilling Supply
26041 Newton Circle
Elko, MN 55020
Phone # 800-637-1940
Fax # 952-461-3403

Section 7

CLEANING AND INSPECTION

CLEANING

Thoroughly clean all parts with suitable cleaning agents. After cleaning, dry with compressed air. Lubricate all machined surfaces with clean oil. Examine each part after cleaning to make certain all foreign matter has been removed.

INSPECTION.

1. Inspect castings for cracks. Replace cracked castings. Inspect tapped holes for damaged threads. Chase damaged threads with a standard tap of the correct size. Replace all castings that cannot be repaired properly.
2. Inspect the teeth of the driving rings. Replace a damaged driving ring.
3. Inspect all flexible hoses for cracks, sponginess, or other damage. Replace a damaged hose.

4. Inspect the diaphragm for surface cracks and hardening. Replace a damaged or questionable diaphragm assembly.

5. Inspect all gear teeth for cleanliness and damage. Foreign particles tend to collect in the root of the gear teeth. Clean thoroughly and repair minor nicks with a fine file. Replace parts with gear teeth that cannot be repaired.

6. It is very important that all air holes and hoses be clean and clear.

7. Inspect the driving plates for cracks, nicks or chips. Replace damaged driving plates.

8. Inspect for cracked or warped pressure plate. Replace the plate if it is damaged.

9. Replace return springs as standard practice after any clutch failure.

N.D.S. Drilling Supply
26041 Newton Circle
Elko, MN 55020
Phone # 800-637-1940
Fax # 952-461-3403

Section 9.

UNIT ASSEMBLY AND INSTALLATION

NOTE

Oiled torque values are used throughout.

ASSEMBLY.

1. Place the hub-and-back plate (2) on a workbench with the hub side up.
2. Place the six release springs (3) in position in the machined counterbored holes in the hub-and-back plate.
3. Install a driving plate (4), center plate (5), driving plate (6), center plate (7), and driving plate (8), onto the hub-and-back plate. Index the center plates to align with the springs and hub-and-back plate.
4. Insert six rollpins (10) into the holes provided in the pressure plate (9). Install the insulator plate (11) onto the rollpins of the pressure plate, and use a rubber mallet to firmly set the insulator plate on the rollpins.
5. Install the pressure and insulator plate assembly onto the hub-and-back plate, making certain to align the bores in the pressure plate with the release springs. After placing the pressure plate in position, center the springs by inserting a drift pin or suitable tool through the holes in the pressure plate.
6. Install the diaphragm assembly (12) against the insulator plate on the hub-and-back plate.
7. Install the front cover plate (13) against the diaphragm assembly hub side down, aligning the hub splines and the air hose connections on the diaphragm assembly.

NOTE

The air inlet holes must be assembled within 7-1/2 degrees of the keyway in the hub-and-back plate. See the applicable planograph in Section 10.

8. Clamp the front cover plate down, and secure it with the special nut (14). Tighten the nut until it bottoms, then unscrew the nut until a

setscrew hole in the nut is aligned with the slot in the hub-and-back plate. Secure the special nut to the hub-and-back plate with the setscrew (15).

9. If replacement is necessary, place the nameplate (16) in position on the front plate, and secure it with two drivescrews (17).

INSTALLATION.

CAUTION

Prior to installation, make certain that the clutch driving plates turn without resistance when the clutch is released. If there is resistance, the clutch must be disassembled and the cause of the resistance corrected.

General.

There are many possible installation configurations for air operated clutches. The scope of this service manual does not permit providing specific information on runout checks for each installation. Consequently, information covering two typical installations is provided; a variation of these two will include most installations. If additional information is required concerning specific installations not covered herein, contact the Twin Disc Service Engineering Department, Racine, Wisconsin 53403.

CAUTION

Most Twin Disc air operated clutches are made to mate with the customer's driving component (i.e. drive gear on a machine, engine flywheel, etc.). It is possible due to mismatch of components to have driving-component to air operated clutch interference. If interference is detected, the clutch should be removed and the interference corrected. The following listed runout checks will indicate interference if it exists.

Twin Disc will not be responsible for system damage caused by driving-component to air operated clutch interference regardless of the cause of the interference.

Alignment.

If the driving ring is bolted directly to the face of the driving component as illustrated in Figure 9-1, proceed as follows:

1. Thoroughly clean the surface of the driving component that mates with the air operated clutch.
2. With a thousandths indicator mounted to the output shaft, check the bore of the driving component for concentricity by rotating the output

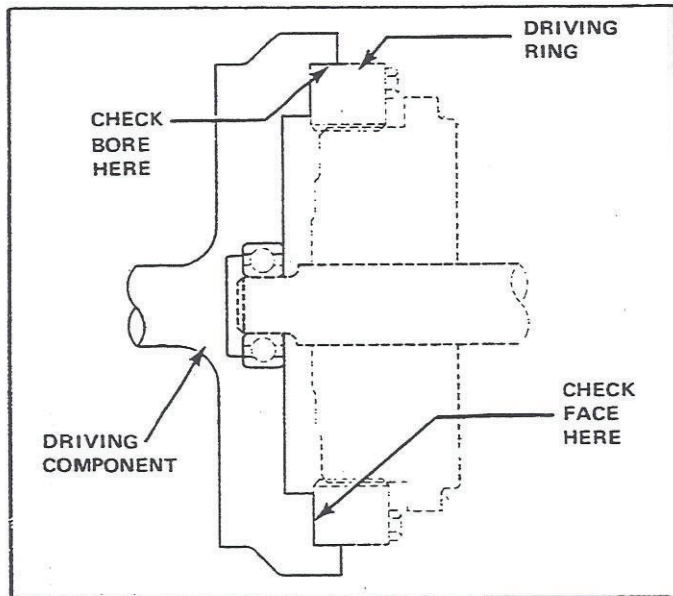

Figure 9-1. Air Operated Clutch with Driving Ring Bolted to the Driving Component (Typical Installation).

shaft. See Figure 9-1. The bore should be concentric to within 0.005 inch total indicator reading.

Check the driving component face. The variations of face runout of the surface to which the driving ring is bolted should not exceed 0.0005 inch per inch of checked diameter.

If the driving component connects to the air operated clutch by means of a spider drive, the angular alignment between the input and output shafts must be checked. See Figure 9-2. This alignment, both vertically and horizontally, must be within 0.001 inch per inch of shaft length. Since there are many different applications of the air operated clutch, the methods of making these checks should be determined by the user to best suit the specific application.

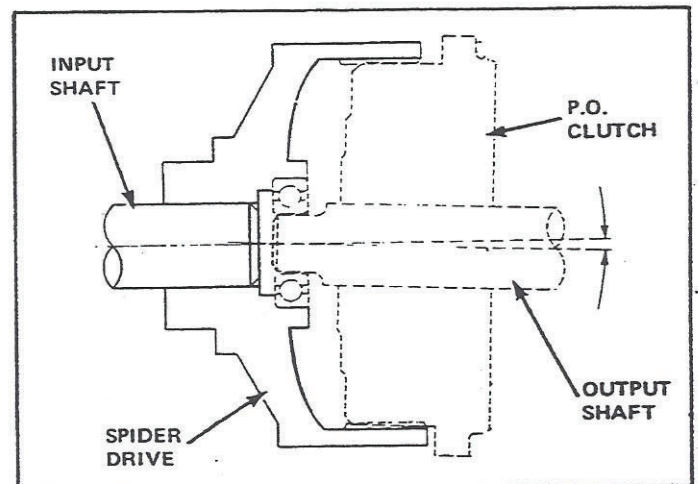
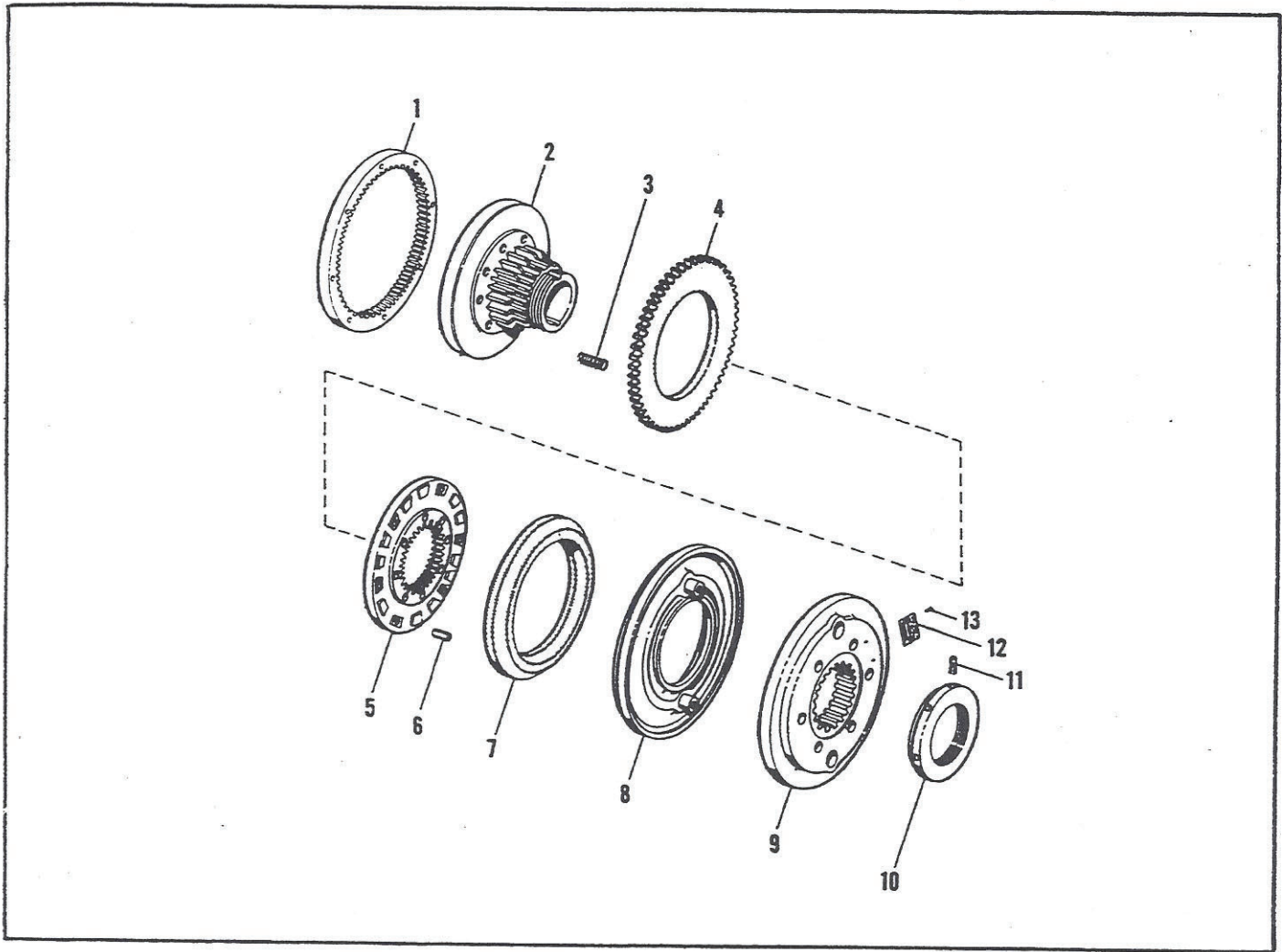

Figure 9-2. Angular Misalignment.

N.D.S. Drilling Supply
26041 Newton Circle
Elko, MN 55020
Phone # 800-637-1940
Fax # 952-461-3403



PO-108 Air Operated Clutch Figure 9-3.

Item	Description	Quantity
1	RING, driving	1
2	PLATE, hub-and-back	1
3	SPRING, release	8
4	PLATE, driving	1
5	PLATE, pressure	1
6	ROLLPIN	6
7	PLATE, insulator	1
8	DIAPHRAGM ASSEMBLY	1
9	PLATE, front cover	1
10	NUT, special	1
11	SETScrew, cup point 1/4 x 5/8	1
12	NAMEPLATE	1
13	DRIVESCREW	2

N.D.S. Drilling Supply
 26041 Newton Circle
 Elko, MN 55020
 Phone # 800-637-1940
 Fax # 952-461-3403

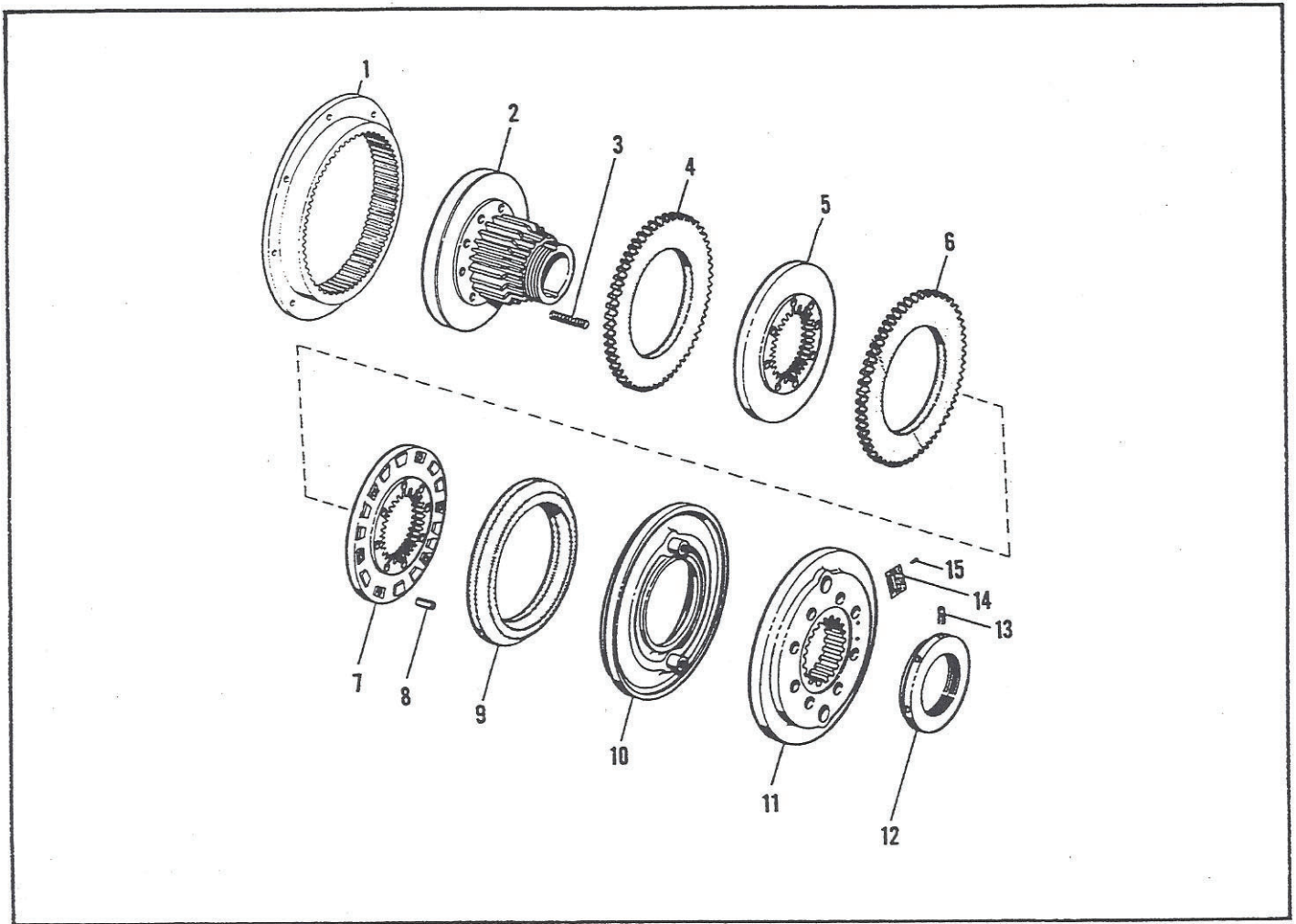

PO-208 Air Operated Clutch Figure 9-4.

Item	Description	Quantity
1	RING, driving	1
2	PLATE, hub-and-back	1
3	SPRING, release	6
4	PLATE, driving	1
5	PLATE, center	1
6	PLATE, driving	1
7	PLATE, pressure	1
8	ROLLPIN	6
9	PLATE, insulator	1
10	DIAPHRAGM ASSEMBLY	1
11	PLATE, front cover	1
12	NUT, special	1
13	SETSCREW, cup point (1/4 x 5/8)	1
14	NAMEPLATE	1
15	DRIVESCREW	2

N.D.S. Drilling Supply
 26041 Newton Circle
 Elko, MN 55020
 Phone # 800-637-1940
 Fax # 952-461-3403

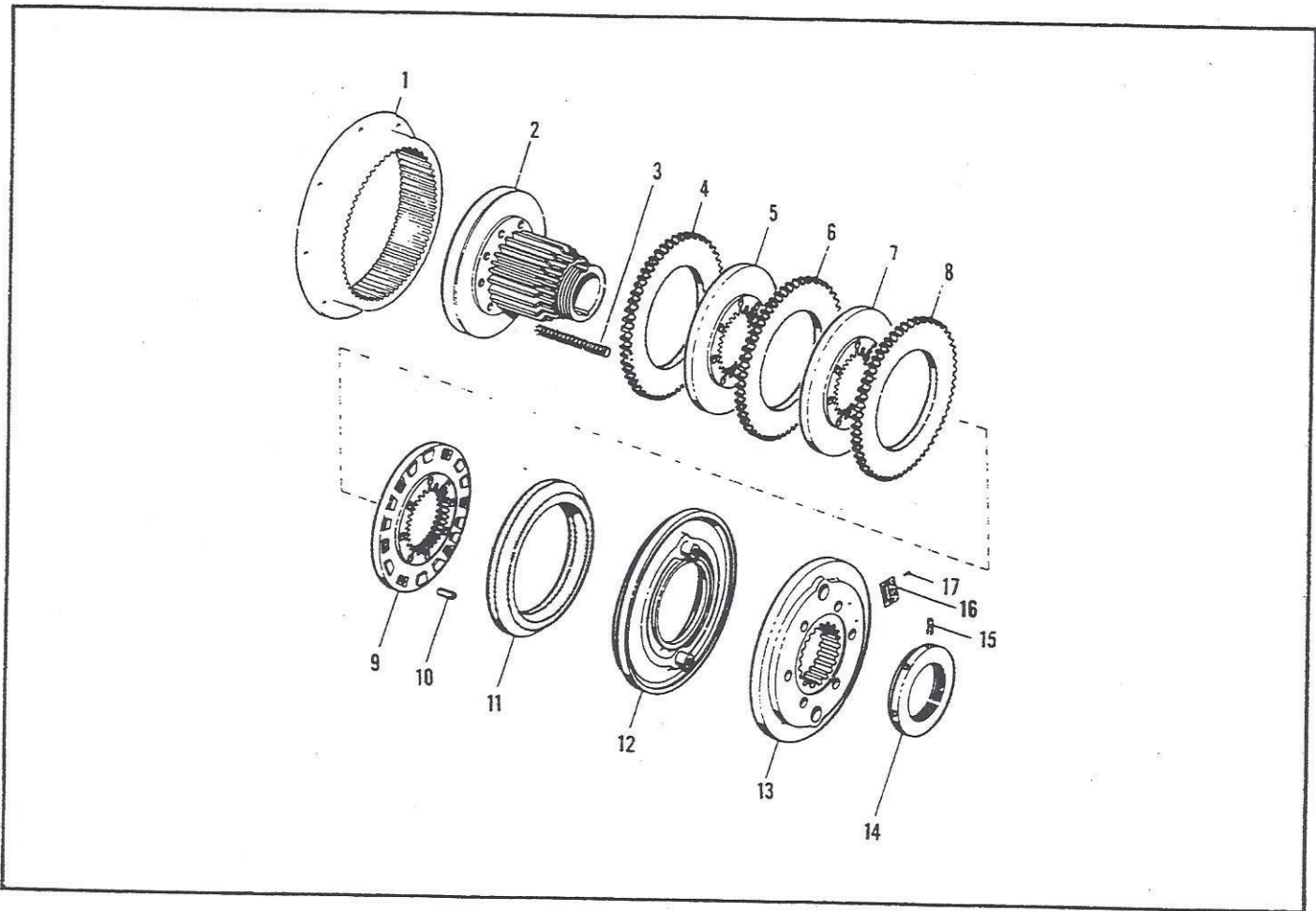

PO-308 Air Operated Clutch Figure 9-5.

Item	Description	Quantity
1	RING, driving	1
2	PLATE, hub-and-back	1
3	SPRING, release	8
4	PLATE, driving	1
5	PLATE, center	1
6	PLATE, driving	1
7	PLATE, center	1
8	PLATE, driving	1
9	PLATE, pressure	1
10	ROLLPIN	6
11	PLATE, insulator	1
12	DIAPHRAGM ASSEMBLY	1
13	PLATE, front cover	1
14	NUT, special	1
15	SETSCREW, cup point (1/4 x 5/8)	1
16	NAMEPLATE	1
17	DRIVESCREW	2

N.D.S. Drilling Supply
 26041 Newton Circle
 Elk, MN 55020
 Phone # 800-637-1940
 Fax # 952-461-3403

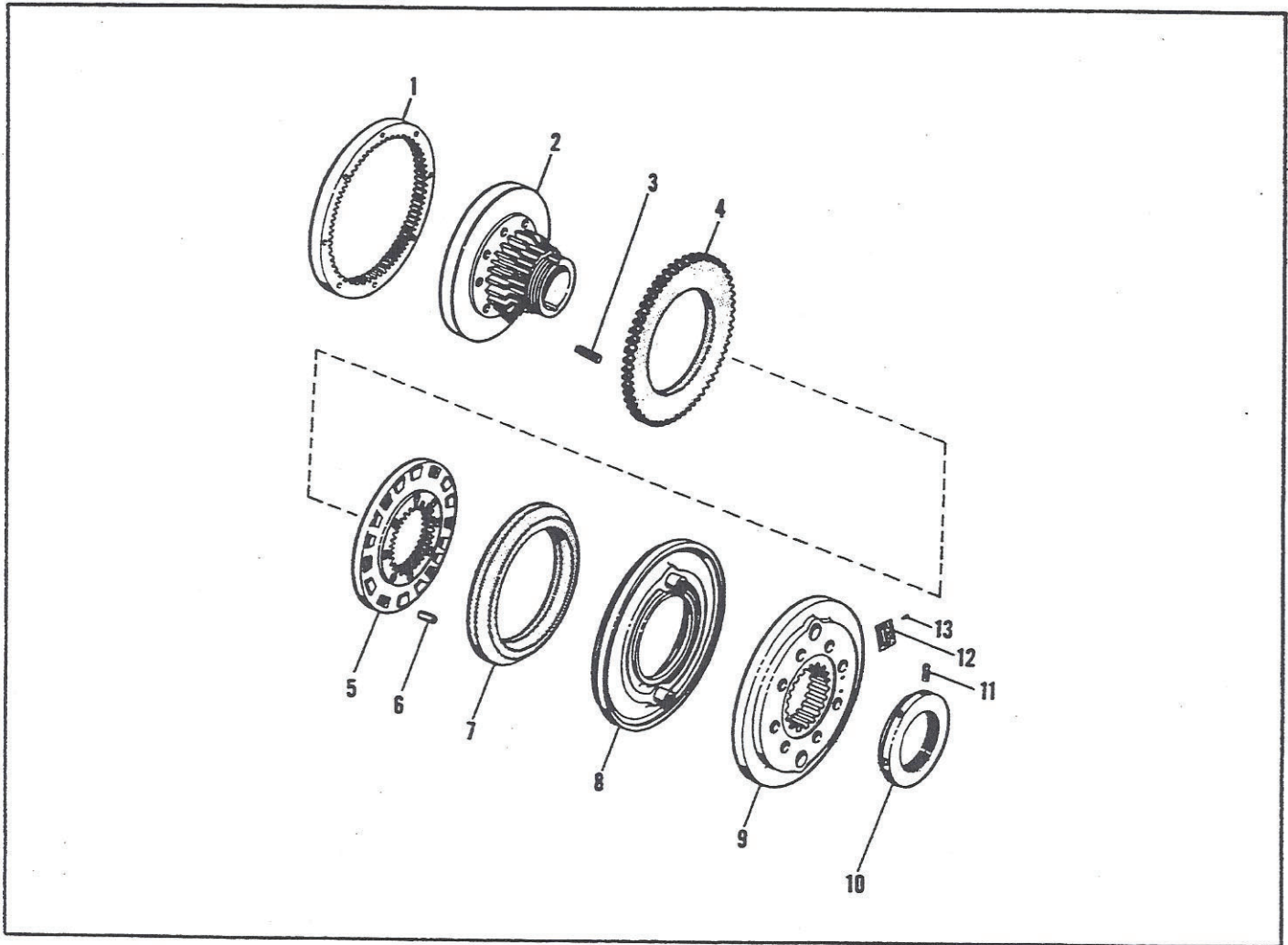

PO-110 Air Operated Clutch Figure 9-6.

Item	Description	Quantity
1	RING, driving	1
2	PLATE, hub-and-back	1
3	SPRING, release	6
4	PLATE, driving	1
5	PLATE, pressure	1
6	ROLLPIN	6
7	PLATE, insulator	1
8	DIAPHRAGM ASSEMBLY	1
9	PLATE, front cover	1
10	NUT, special	1
11	SETSCREW, cup point 1/4 x 5/8	1
12	NAMEPLATE	1
13	DRIVESCREW	2

N.D.S. Drilling Supply
 26041 Newton Circle
 Elko, MN 55020
 Phone # 800-637-1940
 Fax # 952-461-3403

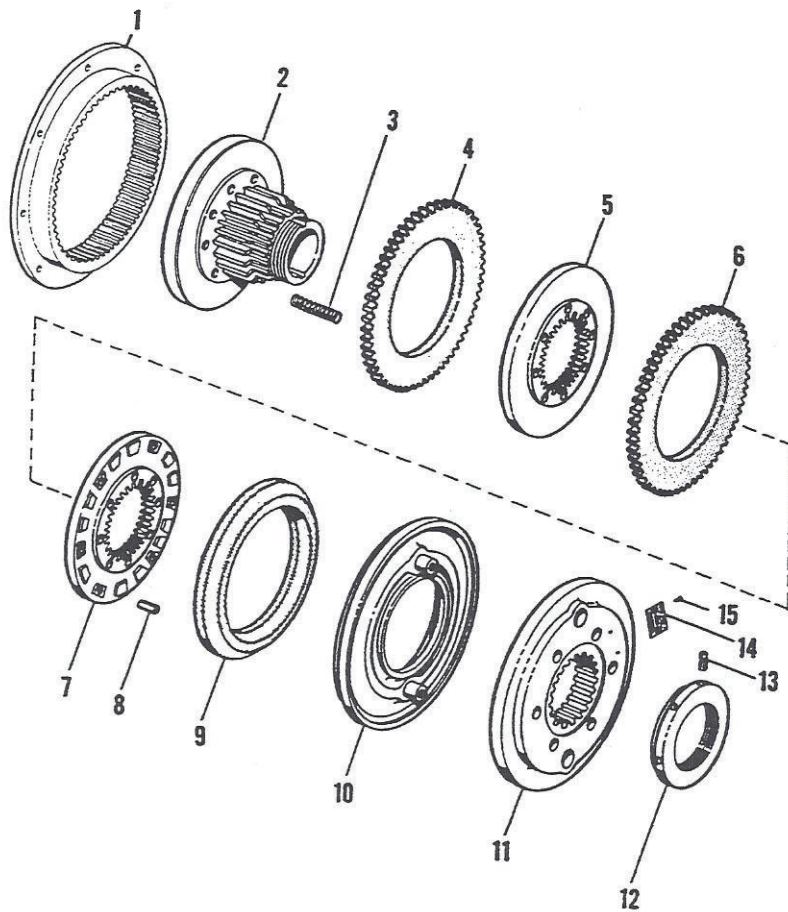

PO-210 Air Operated Clutch Figure 9-7.

Item	Description	Quantity
1	RING, driving	1
2	PLATE, hub-and-back	1
3	SPRING, release	8
4	PLATE, driving	1
5	PLATE, center	1
6	PLATE, driving	1
7	PLATE, pressure	1
8	ROLLPIN	6
9	PLATE, insulator	1
10	DIAPHRAGM ASSEMBLY	1
11	PLATE, front cover	1
12	NUT, special	1
13	SETSCREW, cup point (1/4 x 5/8)	1
14	NAMEPLATE	1
15	DRIVESCREW	2

N.D.S. Drilling Supply
 26041 Newton Circle
 Elko, MN 55020
 Phone # 800-637-1940
 Fax # 952-461-3403

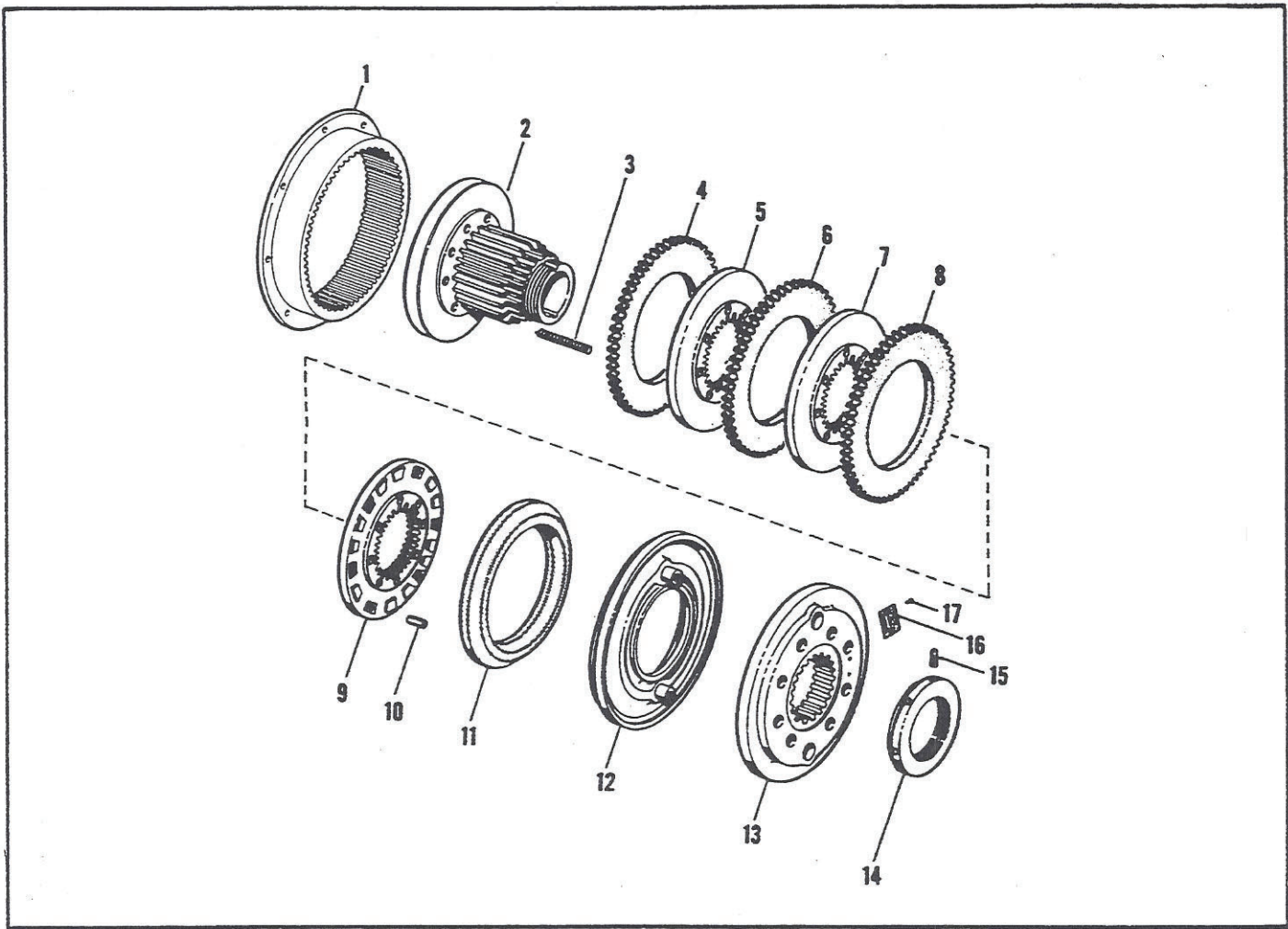

PO-310 Air Operated Clutch Figure 9-8.

Item	Description	Quantity
1	RING, driving	1
2	PLATE, hub-and-back	1
3	SPRING, release	6
4	PLATE, driving	1
5	PLATE, center	1
6	PLATE, driving	1
7	PLATE, center	1
8	PLATE, driving	1
9	PLATE, pressure	1
10	ROLLPIN	6
11	PLATE, insulator	1
12	DIAPHRAGM ASSEMBLY	1
13	PLATE, front cover	1
14	NUT, special	1
15	SETSCREW, cup point (1/4 x 5/8)	1
16	NAMEPLATE	1
17	DRIVESCREW	2

N.D.S. Drilling Supply
 26041 Newton Circle
 Elko, MN 55020
 Phone # 800-637-1940
 Fax # 952-461-3403

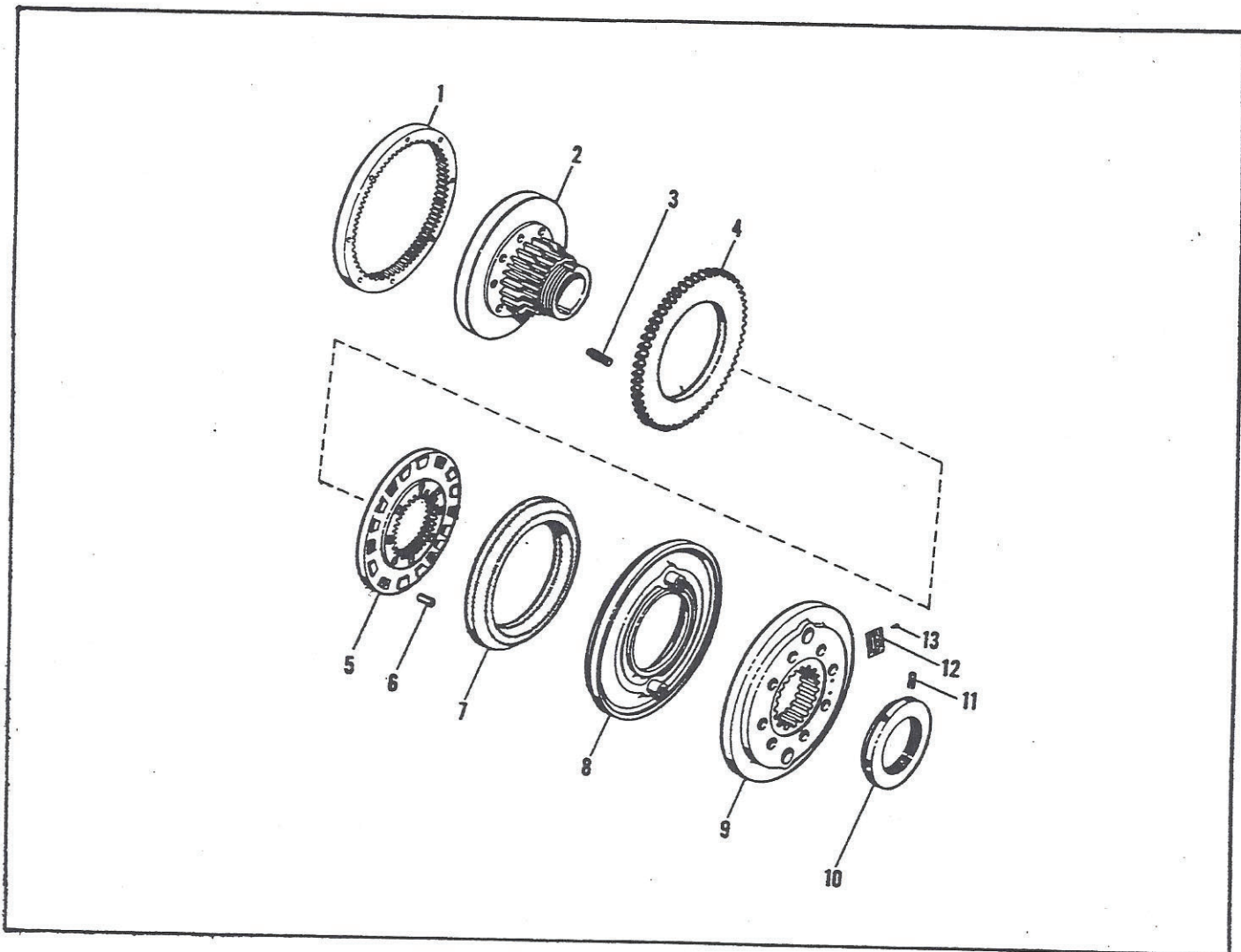

PO-111 Air Operated Clutch Figure 9-9.

Item	Description	Quantity
1	RING, driving	1
2	PLATE, hub-and-back	1
3	SPRING, release	6
4	PLATE, driving	1
5	PLATE, pressure	1
6	ROLLPIN	6
7	PLATE, insulator	1
8	DIAPHRAGM ASSEMBLY	1
9	PLATE, front cover	1
10	NUT, special	1
11	SETSCREW, cup point 1/4 x 5/8	1
12	NAMEPLATE	1
13	DRIVE SCREW	2

N.D.S. Drilling Supply
 26041 Newton Circle
 Elko, MN 55020
 Phone # 800-637-1940
 Fax # 952-461-3403

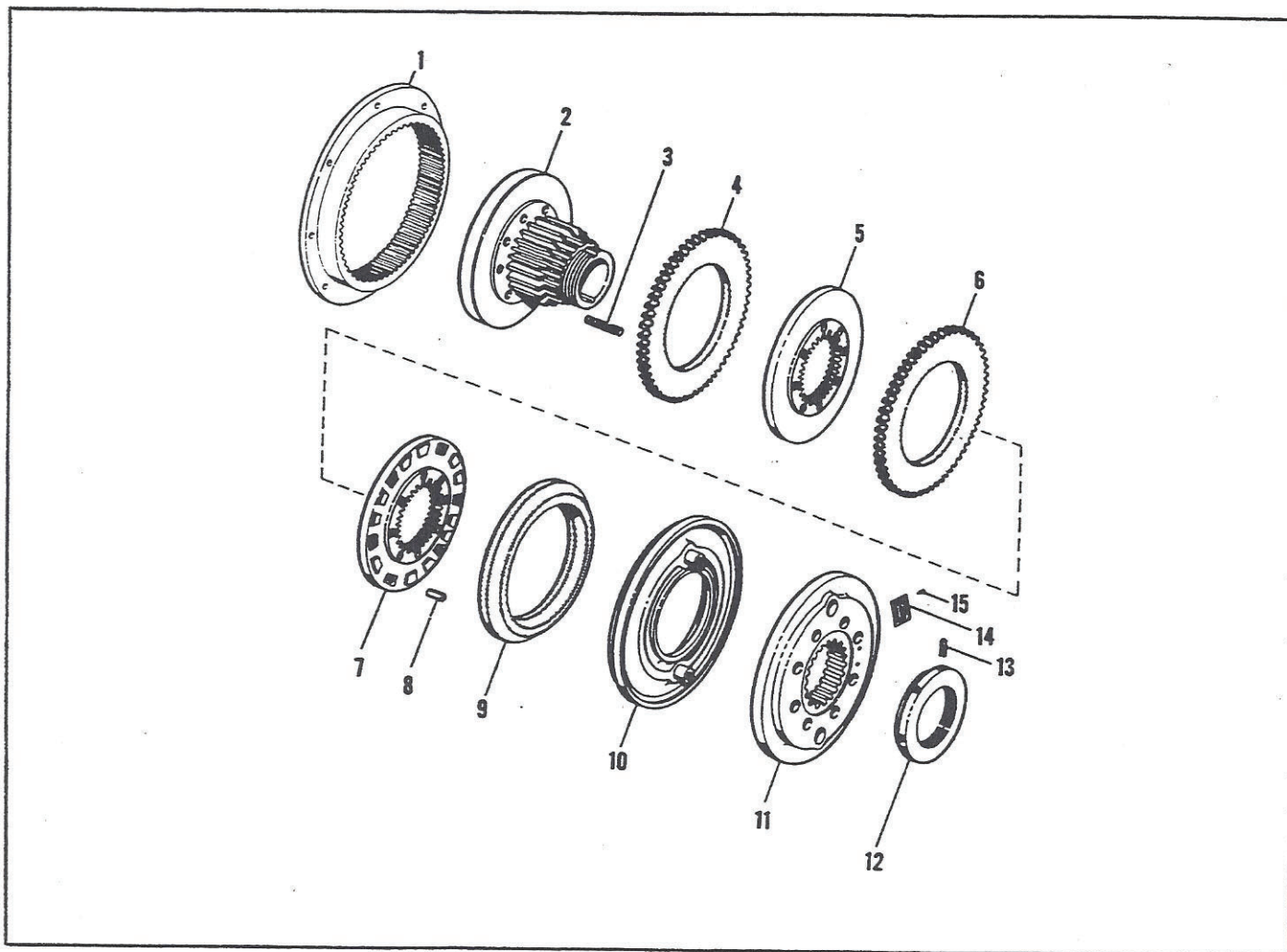

PO-211 Air Operated Clutch Figure 9-10.

Item	Description	Quantity
1	RING, driving	1
2	PLATE, hub-and-back	1
3	SPRING, release	6
4	PLATE, driving	1
5	PLATE, center	1
6	PLATE, driving	1
7	PLATE, pressure	1
8	ROLLPIN	6
9	PLATE, insulator	1
10	DIAPHRAGM ASSEMBLY	1
11	PLATE, front cover	1
12	NUT, special	1
13	SETSCREW, cup point (1/4 x 5/8)	1
14	NAMEPLATE	1
15	DRIVESCREW	2

N.D.S. Drilling Supply
 26041 Newton Circle
 Elko, MN 55020
 Phone # 800-637-1940
 Fax # 952-461-3403

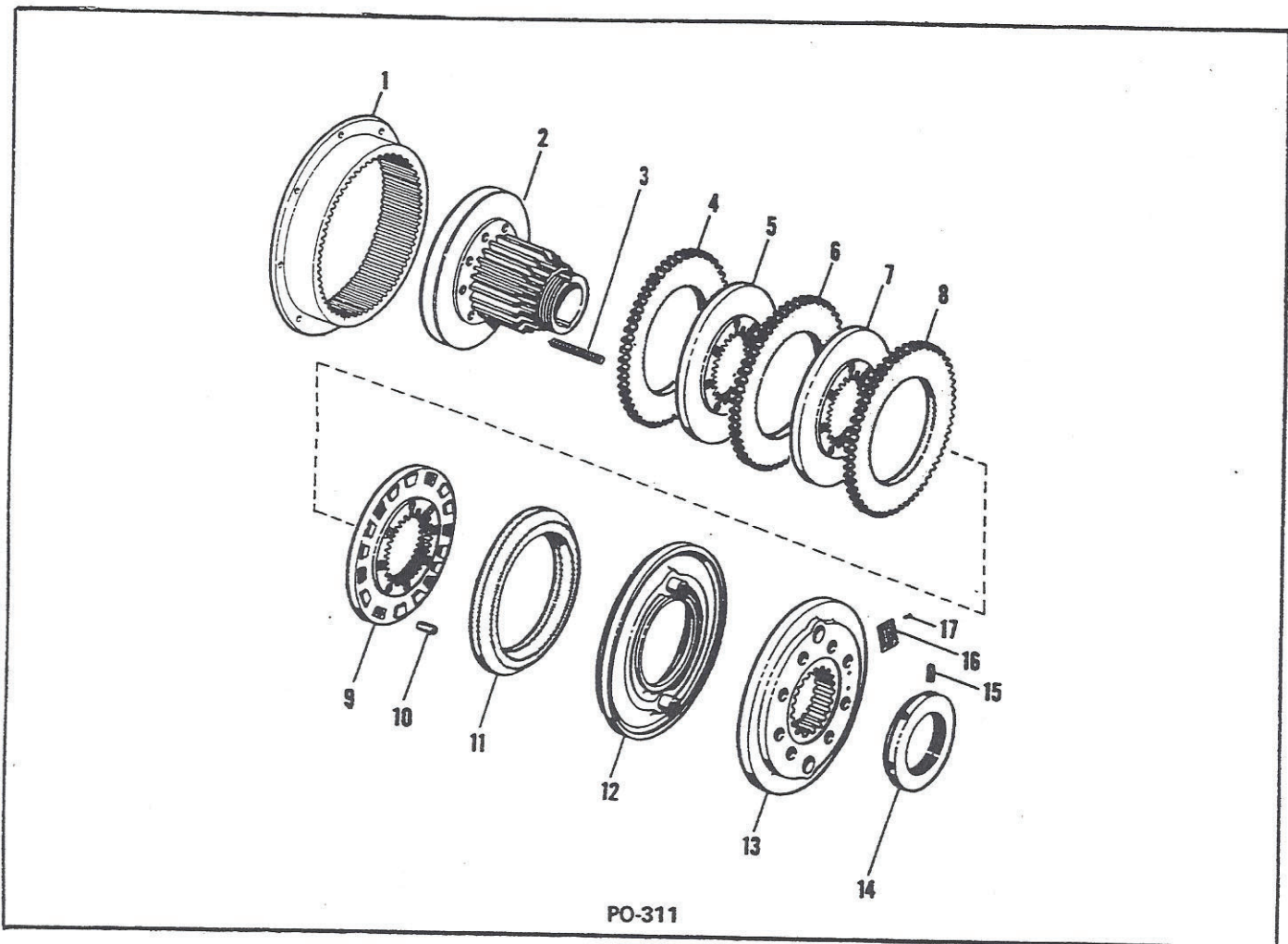

PO-311 Air Operated Clutch Figure 9-11.

Item	Description	Quantity
1	RING, driving	1
2	PLATE, hub-and-back	1
3	SPRING, release	6
4	PLATE, driving	1
5	PLATE, center	1
6	PLATE, driving	1
7	PLATE, center	1
8	PLATE, driving	1
9	PLATE, pressure	1
10	ROLLPIN	6
11	PLATE, insulator	1
12	DIAPHRAGM ASSEMBLY	1
13	PLATE, front cover	1
14	NUT, special	1
15	SETSCREW, cup point (1/4 x 5/8)	1
16	NAMEPLATE	1
17	DRIVESCREW	2

N.D.S. Drilling Supply
 26041 Newton Circle
 Elko, MN 55020
 Phone # 800-637-1940
 Fax # 952-461-3403

Section 10.

ACCESSORIES AND OPTIONAL EQUIPMENT

AIR CLUTCH INSTALLATION. (Figure 10-1)

Twin Disc Model PO Clutches will transmit high torque at moderate air pressures with the most basic air equipment. In addition to the clutch, the following items are necessary:

1. Two lengths of 1/4 inch minimum ID hose and fittings to connect the diaphragm air chamber to clutch shaft drilled passages.
2. A rotary end-joint to connect outside air supply to clutch shaft drilled passage. Available from Twin Disc.
3. A three-way air control valve. Available from Twin Disc.
4. A connecting hose between control valve and end-joint.

NOTE

A lubricant is not required. If a lubricant must be used for other equipment in the line, use only straight mineral oil to avoid deterioration of the clutch diaphragm.

ROTATING AIR UNION.

To introduce air to the clutch, the clutch shaft must be drilled, and the union shown in Figure 10-2 must be screwed into the shaft end. The seals are suitable for pressures up to 150 psi and are capable of maximum clutch speeds without leakage or overheating. This union is manufactured by the Deublin Company and uses a carbon optically-flat face seal running against a microlapped steel rotor. The union is readily serviceable in the field and does not need to be returned to the factory for repair. For information, regarding repair and assembly of the M-2301-A air union, refer to Deublin's repair and assembly instructions in this manual.

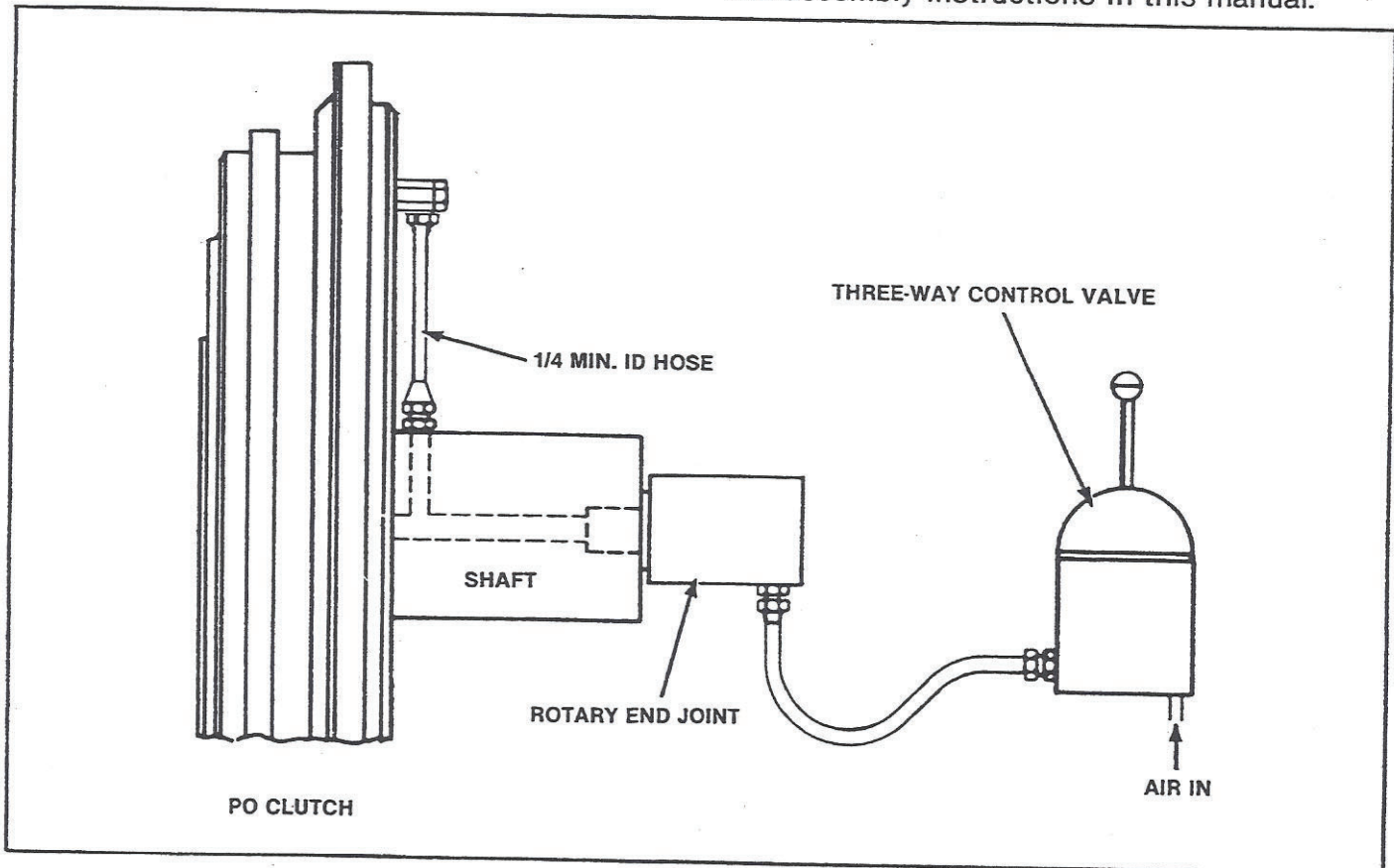

Figure 10-1. Installation Schematic.

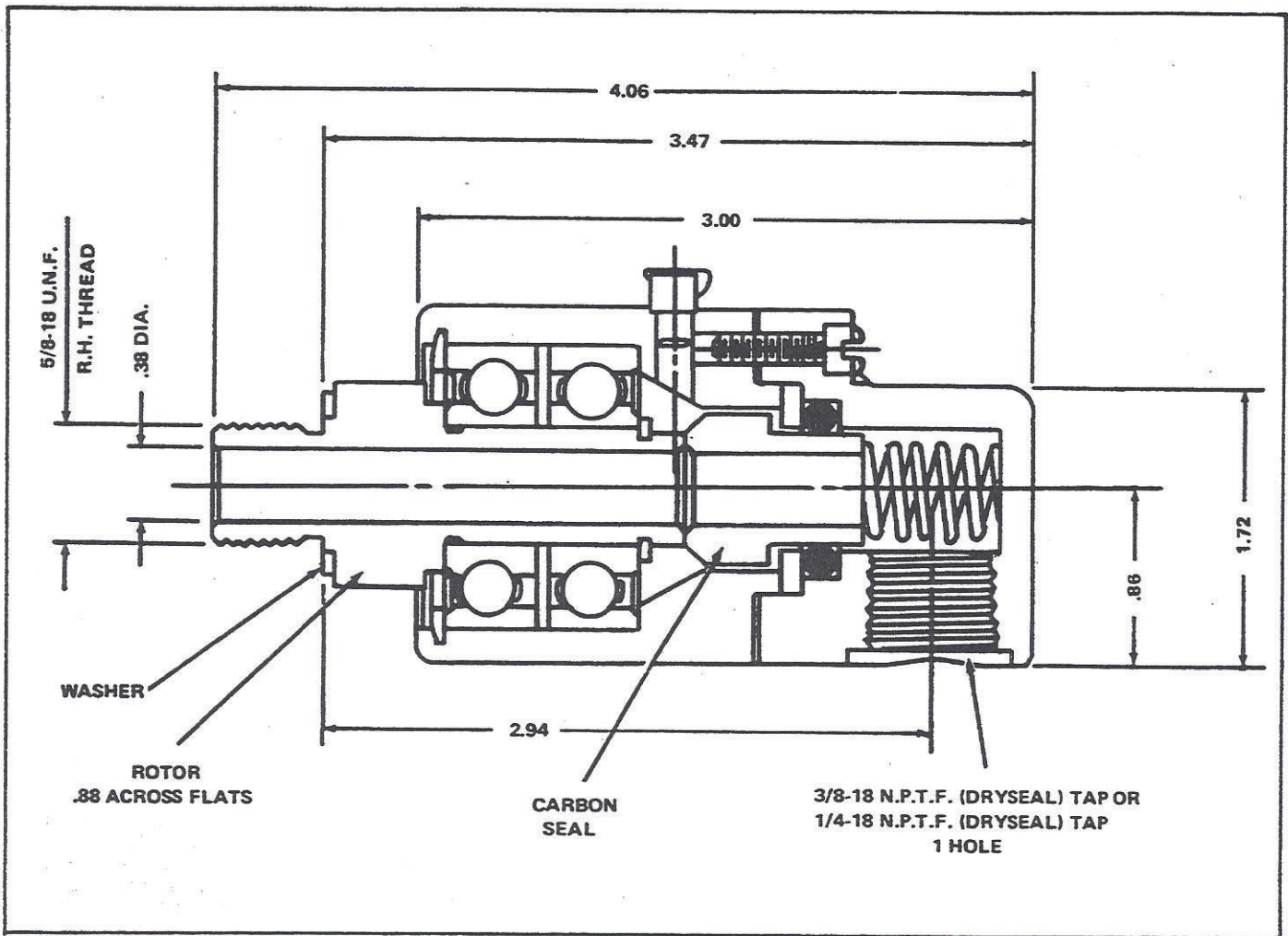





Figure 10-2. M-2301-A Air Union for Air Clutches.

N.D.S. Drilling Supply
26041 Newton Circle
Elko, MN 55020
Phone # 800-637-1940
Fax # 952-461-3403

TORQUE VALUES

FOR TIGHTENING CAPSCREWS, BOLTS, NUTS, TUBE FITTINGS AND PLUGS.

CAP SCREWS, BOLTS & NUTS					
TORQUE (LB. FT.) FOR COURSE AND FINE THREADS (1)					
NOMINAL THREAD DIAMETER	SAE GRADE 5		SAE GRADE 8		Screws for Universal Joint Bearing Caps
	AS (2) RECEIVED	LUBRI- (3) CATED	AS (2) RECEIVED	LUBRI- (3) CATED	
1/4	9 ± 1	7 ± 1	14 ± 1	11 ± 1	----
5/16	19 ± 2	15 ± 2	27 ± 2	22 ± 2	----
3/8	33 ± 3	27 ± 2	46 ± 4	38 ± 3	----
7/16	52 ± 4	40 ± 3	73 ± 6	60 ± 5	64 ± 4
1/2	80 ± 6	65 ± 5	112 ± 8	90 ± 7	100 ± 7
9/16	112 ± 8	90 ± 8	158 ± 12	130 ± 10	----
5/8	158 ± 12	130 ± 10	224 ± 16	180 ± 15	190 ± 10
3/4	280 ± 20	225 ± 20	390 ± 30	320 ± 25	330 ± 17
7/8	448 ± 32	360 ± 30	630 ± 50	510 ± 40	510 ± 25
1	680 ± 50	540 ± 45	960 ± 70	775 ± 60	----
1 1/8	850 ± 60	675 ± 60	1360 ± 100	1100 ± 85	----
1 1/4	1175 ± 85	925 ± 75	1850 ± 150	1500 ± 125	----
3 DASHES 120° APART		6 DASHES 60° APART		 (4) 12 Pt. Head and Undercut Body	
					
SAE STANDARD HEX BOLT HEAD MARKINGS					

TAPERED PIPE PLUGS		
RECOMMENDED TORQUE (LB. FT.)		
NPTF SIZE	LUBRICATED (a)	
	In Cast Iron or Steel	In Aluminum
1/16-27	8.5 ± 1.0	5.5 ± 0.7
1/8-27	10.5 ± 1.3	6.5 ± 0.8
1/4-18	25 ± 3	16 ± 2
3/8-18	27 ± 3	17 ± 2
1/2-14	50 ± 6	30 ± 4
3/4-14	54 ± 7	34 ± 4
1 -11 1/2	80 ± 10	50 ± 6
1 1/4-11 1/2	85 ± 10	55 ± 7
1 1/2-11 1/2	85 ± 10	55 ± 7

(a) THE LUBRICANT IS TO BE JOHN CRANE INSOLUBLE PLASTIC LEAD SEAL NO. 2 OR EQUIVALENT OR LOCTITE NO. 92 OR EQUIVALENT AND PLUGS ARE TO BE CAPABLE OF REMOVAL WITHOUT DAMAGE. OVERTIGHTENING MAY CAUSE INITIAL LEAKAGE PLUS POTENTIAL REMOVAL DAMAGE. AN OPTION OF A MAX. OF TWO FULL TURNS AFTER FINGER TIGHTENING THE PLUG MAY BE USED IF REQUIRED AND IF REMOVAL CONDITIONS ARE MET.

(1) THESE TORQUE VALUES APPLY TO USE OF IRONS, STEELS AND ALUMINUM TAPPED HOLES.

THE THREAD ENGAGEMENT LENGTH IN ALUMINUM IS TO BE TWICE THE NOMINAL THREAD DIAMETER AND ENGAGEMENT LENGTH RATIO IS TO BE 1.5 FOR IRONS AND SOFT STEEL. WHEN ZINC PLATING IS USED, LUBRICATE THE ZINC PLATED SURFACES OF THE SCREWS AND/OR NUTS AND USE SPECIAL TORQUE VALUES.

(2) USE FOR ALL CAPSCREWS, BOLTS AND NUTS COATED ONLY WITH THE FASTENER MANUFACTURER'S RUST PREVENTATIVE OIL AND USE FOR PARTS WIPED OR WASHED NEARLY FREE OF OIL. DO NOT USE FOR PLATED PARTS.

(3) USE FOR ALL CAPSCREWS AND NUTS WHOSE THREADS AND WASHER FACE ARE LUBRICATED, ALSO FOR SCREWS OR NUTS WHOSE WASHER FACE IS ASSEMBLED AGAINST A HARDENED WASHER OR SMOOTH FINISHED HARD PART. (R_c 40 OR ABOVE AND 40AA MAX.). ALSO USE FOR PLATED SCREWS (EXCEPT ZINC PLATED). LUBRICATING THE THREADS AND SCREW OR NUT FACE WITH SAE 20 OR 30 OIL IS RECOMMENDED FOR BEST RESULTS FOR ALL THE GRADE 8 SCREWS AND IS REQUIRED FOR ALL THE UNIVERSAL JOINT BEARING CAPSCREWS.

DO NOT USE MOLY-DISULFIDE, WHITE LEAD, COPPER FILLED OR OTHER SUCH FILLED LUBRICANTS WITH THESE TORQUE VALUES. SUCH LUBRICANTS REQUIRE SPECIAL TORQUE VALUES.

(4) SOCKET HEAD SCREWS AND 12 POINT HEAD SCREWS WITH FULL BODY ARE GRADE 8 OR BETTER QUALITY AND ARE TO BE ASSEMBLED WITH THE ABOVE TORQUE VALUES.

Section 12

ENGINEERING DRAWINGS — DATA

The following engineering drawings of the product for which this manual was written are included for your convenience.

N.D.S. Drilling Supply
26041 Newton Circle
Elko, MN 55020
Phone # 800-637-1940
Fax # 952-461-3403

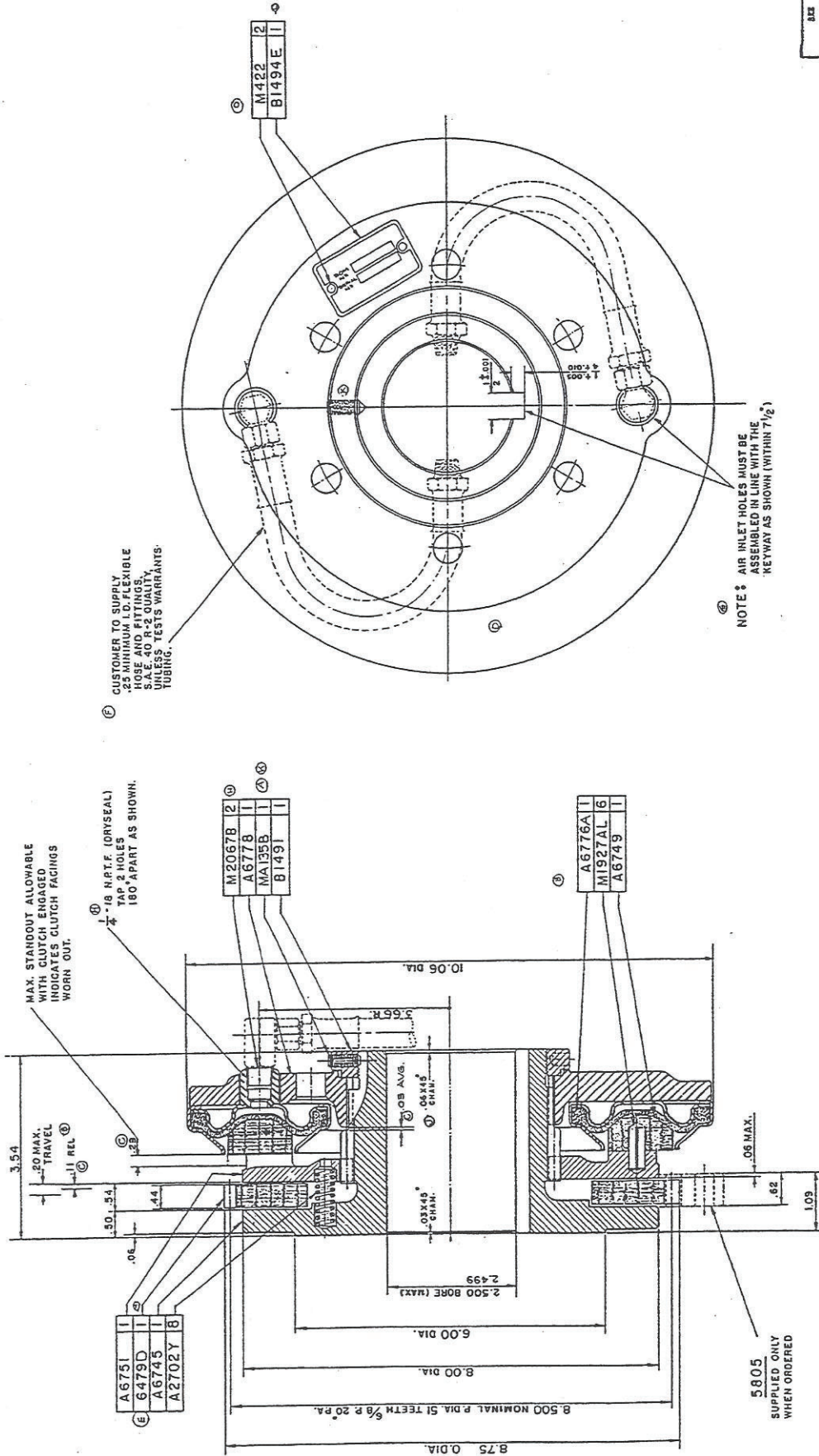

(C) CUSTOMER TO SUPPLY HOSE AND FITTINGS. S.A.E. 40 R-2 QUALITY, UNLESS TESTS WARRANT TUBING.

(D) MAX. STANDOUT ALLOWABLE WITH CLUTCH ENGAGED INDICATES CLUTCH FACINGS WORN OUT.

(E) NOTE: AIR INLET HOLES MUST BE ASSEMBLED IN LINE WITH THE KEYWAY AS SHOWN (WITHIN 7/16)

5805 SUPPLIED ONLY WHEN ORDERED

N.D.S. Drilling Supply
 26041 Newton Circle
 Elko, MN 55020
 Phone # 800-637-1940
 Fax # 952-461-3403

SEE INQUIRY
 1-503-
 FOR LISTING C00071213
 MAIL 872002

YWIN DRES
 X9720

PATENT APPLIED FOR
 PO 108 AIR CLUTCH

NOTICE: THIS DRAWING CONTAINS PROPRIETARY INFORMATION AND IS NOT TO BE REPRODUCED OR TRANSMITTED IN ANY FORM OR BY ANY MEANS, ELECTRONIC OR MECHANICAL, INCLUDING PHOTOCOPYING, RECORDING, OR BY ANY INFORMATION STORAGE AND RETRIEVAL SYSTEM. THIS NOTICE IS NOT INTENDED TO LIMIT OR AFFECT THE RIGHTS OF OTHERS UNDER PATENT RIGHTS OR OTHER RIGHTS IN INTELLECTUAL PROPERTY. U.S. PATENT AND TRADEMARK OFFICE.

SEE X 9724 FOR AVAILABLE SPIDERS

REV	DATE	BY	CHKD	APP'D	DESCRIPTION
1	10/13/87	J	J	J	REVISED
2	10/13/87	J	J	J	REVISED
3	10/13/87	J	J	J	REVISED
4	10/13/87	J	J	J	REVISED
5	10/13/87	J	J	J	REVISED
6	10/13/87	J	J	J	REVISED
7	10/13/87	J	J	J	REVISED
8	10/13/87	J	J	J	REVISED
9	10/13/87	J	J	J	REVISED
10	10/13/87	J	J	J	REVISED
11	10/13/87	J	J	J	REVISED
12	10/13/87	J	J	J	REVISED
13	10/13/87	J	J	J	REVISED
14	10/13/87	J	J	J	REVISED
15	10/13/87	J	J	J	REVISED
16	10/13/87	J	J	J	REVISED
17	10/13/87	J	J	J	REVISED
18	10/13/87	J	J	J	REVISED
19	10/13/87	J	J	J	REVISED
20	10/13/87	J	J	J	REVISED
21	10/13/87	J	J	J	REVISED
22	10/13/87	J	J	J	REVISED
23	10/13/87	J	J	J	REVISED
24	10/13/87	J	J	J	REVISED
25	10/13/87	J	J	J	REVISED
26	10/13/87	J	J	J	REVISED
27	10/13/87	J	J	J	REVISED
28	10/13/87	J	J	J	REVISED
29	10/13/87	J	J	J	REVISED
30	10/13/87	J	J	J	REVISED
31	10/13/87	J	J	J	REVISED
32	10/13/87	J	J	J	REVISED
33	10/13/87	J	J	J	REVISED
34	10/13/87	J	J	J	REVISED
35	10/13/87	J	J	J	REVISED
36	10/13/87	J	J	J	REVISED
37	10/13/87	J	J	J	REVISED
38	10/13/87	J	J	J	REVISED
39	10/13/87	J	J	J	REVISED
40	10/13/87	J	J	J	REVISED
41	10/13/87	J	J	J	REVISED
42	10/13/87	J	J	J	REVISED
43	10/13/87	J	J	J	REVISED
44	10/13/87	J	J	J	REVISED
45	10/13/87	J	J	J	REVISED
46	10/13/87	J	J	J	REVISED
47	10/13/87	J	J	J	REVISED
48	10/13/87	J	J	J	REVISED
49	10/13/87	J	J	J	REVISED
50	10/13/87	J	J	J	REVISED

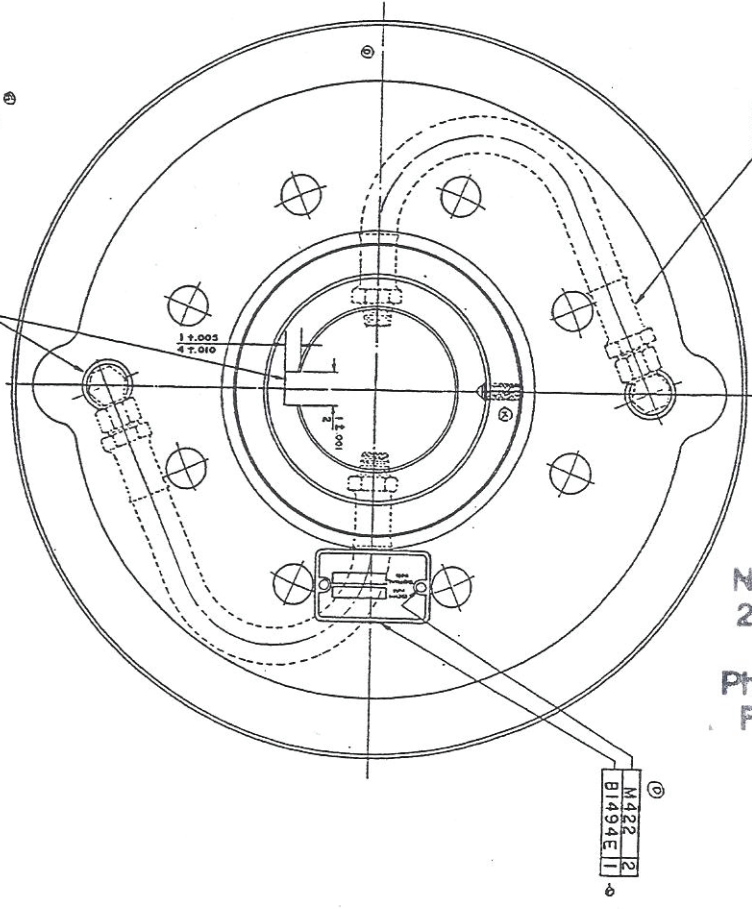
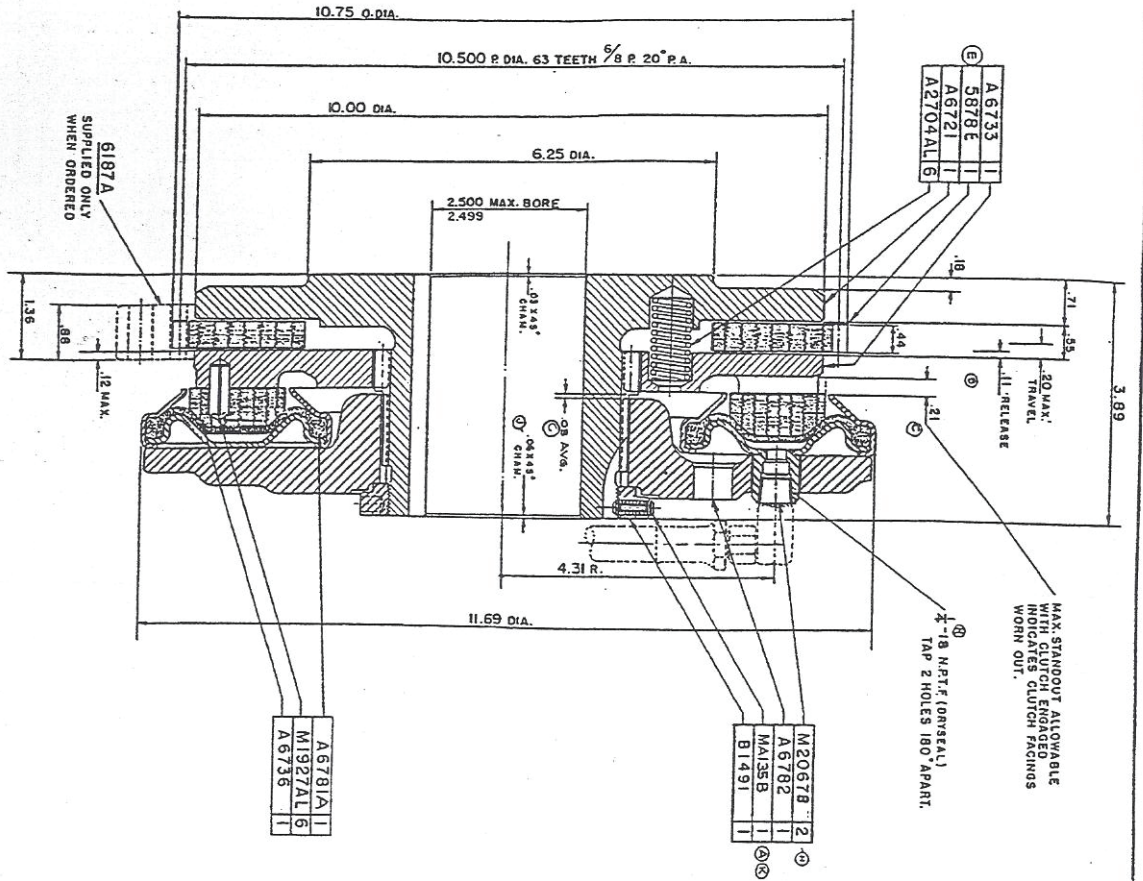

N.D.S. Drilling Supply
 26041 Newton Circle
 Elko, MN 55020
 Phone # 800-637-1940
 Fax # 952-461-3403

REV	DATE	BY	CHKD	DESCRIPTION
1	11/13/11	JL	JL	ISSUE FOR MANUFACTURE
2	11/13/11	JL	JL	REVISIONS
3	11/13/11	JL	JL	REVISIONS
4	11/13/11	JL	JL	REVISIONS
5	11/13/11	JL	JL	REVISIONS
6	11/13/11	JL	JL	REVISIONS
7	11/13/11	JL	JL	REVISIONS
8	11/13/11	JL	JL	REVISIONS
9	11/13/11	JL	JL	REVISIONS
10	11/13/11	JL	JL	REVISIONS
11	11/13/11	JL	JL	REVISIONS
12	11/13/11	JL	JL	REVISIONS
13	11/13/11	JL	JL	REVISIONS
14	11/13/11	JL	JL	REVISIONS
15	11/13/11	JL	JL	REVISIONS
16	11/13/11	JL	JL	REVISIONS
17	11/13/11	JL	JL	REVISIONS
18	11/13/11	JL	JL	REVISIONS
19	11/13/11	JL	JL	REVISIONS
20	11/13/11	JL	JL	REVISIONS
21	11/13/11	JL	JL	REVISIONS
22	11/13/11	JL	JL	REVISIONS
23	11/13/11	JL	JL	REVISIONS
24	11/13/11	JL	JL	REVISIONS
25	11/13/11	JL	JL	REVISIONS
26	11/13/11	JL	JL	REVISIONS
27	11/13/11	JL	JL	REVISIONS
28	11/13/11	JL	JL	REVISIONS
29	11/13/11	JL	JL	REVISIONS
30	11/13/11	JL	JL	REVISIONS

NOTICE: THIS DRAWING CONTAINS PROPRIETARY INFORMATION AND IS NOT TO BE REPRODUCED OR TRANSMITTED IN ANY FORM OR BY ANY MEANS, ELECTRONIC OR MECHANICAL, INCLUDING PHOTOCOPYING, RECORDING, OR BY ANY INFORMATION STORAGE AND RETRIEVAL SYSTEM. THE DESIGN OF THIS DRAWING IS THE PROPERTY OF N.D.S. DRILLING SUPPLY. ALL RIGHTS ARE RESERVED. U.S. GOVERNMENT OF PATENT RIGHTS RESERVED.

PATENT APPLIED FOR
 PO 110 AIR CLUTCH
 DATE: 8-21-11
 INVENTOR: J.L. JENSEN
 WYMAN DORGE
 1400 10th Ave S.E.
 Elko, MN 55020
 X9714

AIR BORE
 8.202
 NON LAMINATE CONDITIONS
 M.L. STEDS

SEE X9719 FOR AVAILABLE SPINDERS

SEE SHEET
S. 593
FOR LIMITED CONDITIONS
ALL SPEEDS

TWIN DISC
X9709

PATENT APPLIED FOR
PO III AIR CLUTCH

REV. NO.	REV. DATE	REV. BY	REV. DESCRIPTION
1			INITIAL
2			INITIAL
3			INITIAL
4			INITIAL
5			INITIAL
6			INITIAL
7			INITIAL
8			INITIAL
9			INITIAL
10			INITIAL
11			INITIAL
12			INITIAL

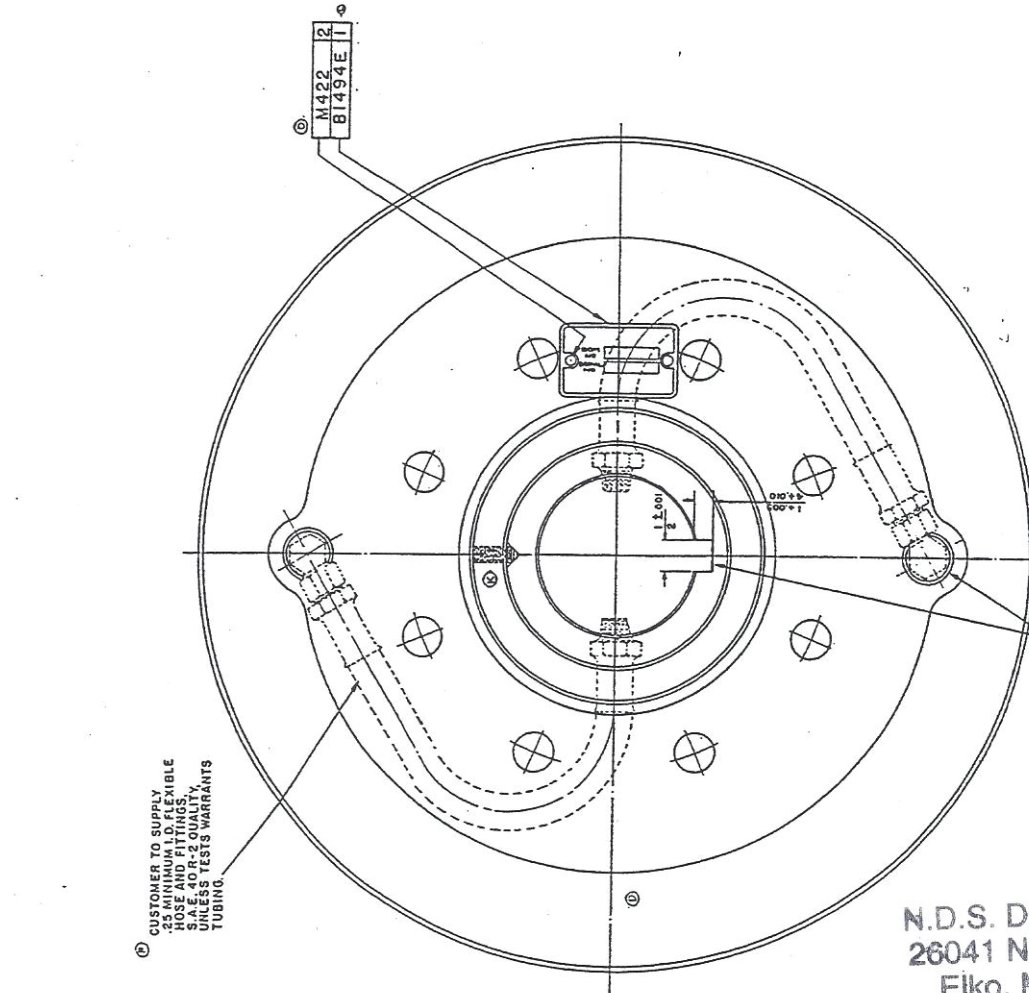

① CUSTOMER TO SUPPLY
.25 MINIMUM I.D. FLEXIBLE
HOSE AND FITTINGS.
QUALITY OF HOSE AND FITTINGS
UNLESS TESTS WARRANTS
TUBING.

② NOTE: AIR INLET HOLES MUST BE
ASSEMBLED IN LINE WITH THE
KEYWAY AS SHOWN (WITHIN 7/2")

N.D.S. Drilling Supply
26041 Newton Circle
Elko, MN 55020
Phone # 800-637-1940
Fax # 952-461-3403

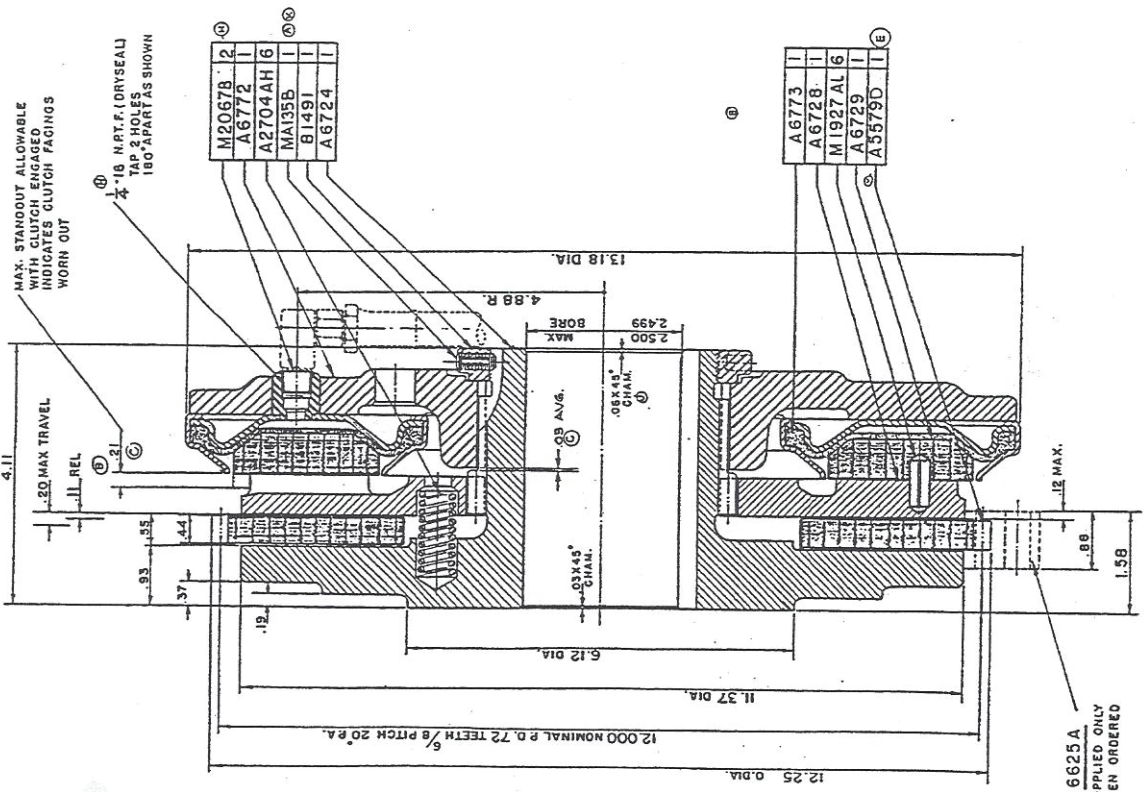

MAX. STANDOUT ALLOWABLE
WITH CLUTCH ENGAGED
INDICATES CLUTCH FACINGS
WORN OUT

③ 1/4" 18 N.P.T.F. (DRYSEAL)
TAP 2 HOLES
180° APART AS SHOWN

M2067B	2	④
A6772	1	
A2704AH	6	
MA135B	1	⑤
B1491	1	
A6724	1	

A6773	1	⑥
A6728	1	
M1927AL	6	
A6729	1	
A5579D	1	⑦

6625A
SUPPLIED ONLY
WHEN ORDERED

REV. NO.	REV. DATE	REV. BY	REV. DESCRIPTION
1			INITIAL
2			INITIAL
3			INITIAL
4			INITIAL
5			INITIAL
6			INITIAL
7			INITIAL
8			INITIAL
9			INITIAL
10			INITIAL
11			INITIAL
12			INITIAL

SEE X9710 FOR AVAILABLE SPIDERS

SEE SHEET
8 503
FOR MULTIPLE COPIES OF THIS
AND
SHEETS

TWIN DISC
X9710

DATE	REV	BY	CHKD
10/11/81	1
10/11/81	2
10/11/81	3
10/11/81	4

PATENT APPLIED FOR
PO 211 AIR CLUTCH

WHICH THIS PART CONTAINS PROPRIETARY INFORMATION AND IS NOT TO BE
REPRODUCED OR TRANSMITTED IN ANY FORM OR BY ANY MEANS,
ELECTRONIC, MECHANICAL, PHOTOCOPYING, RECORDING, OR BY ANY INFORMATION STORAGE AND RETRIEVAL SYSTEM,
WITHOUT THE WRITTEN PERMISSION OF THE PATENT AND TRADEMARK OFFICE OF THE UNITED STATES DEPARTMENT OF COMMERCE.

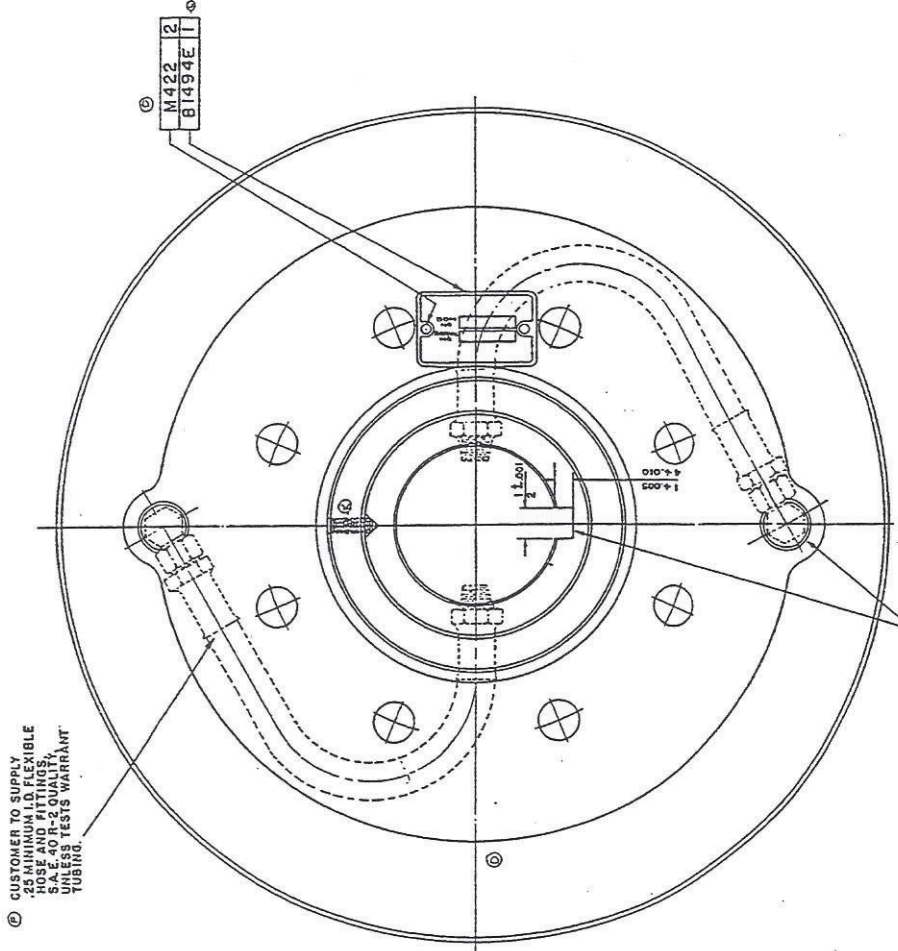

② CUSTOMER TO SUPPLY
APPLICABLE
HOSE AND FITTINGS
S.A.E. 40 R-2 QUALITY,
UNLESS TESTS WARRANT
TUBING.

NOTE: AIR INLET HOLES MUST BE
ASSEMBLED IN LINE WITH THE
KEYWAY AS SHOWN WITHIN 1/16"

MAX. STANDOUT ALLOWABLE
WITH CLUTCH ENGAGED
INDICATES CLUTCH FACINGS
WORN OUT.

④ ±.18 N.P.T.F. (DRYSEAL)
TAP 2 HOLES
180° APART AS SHOWN.

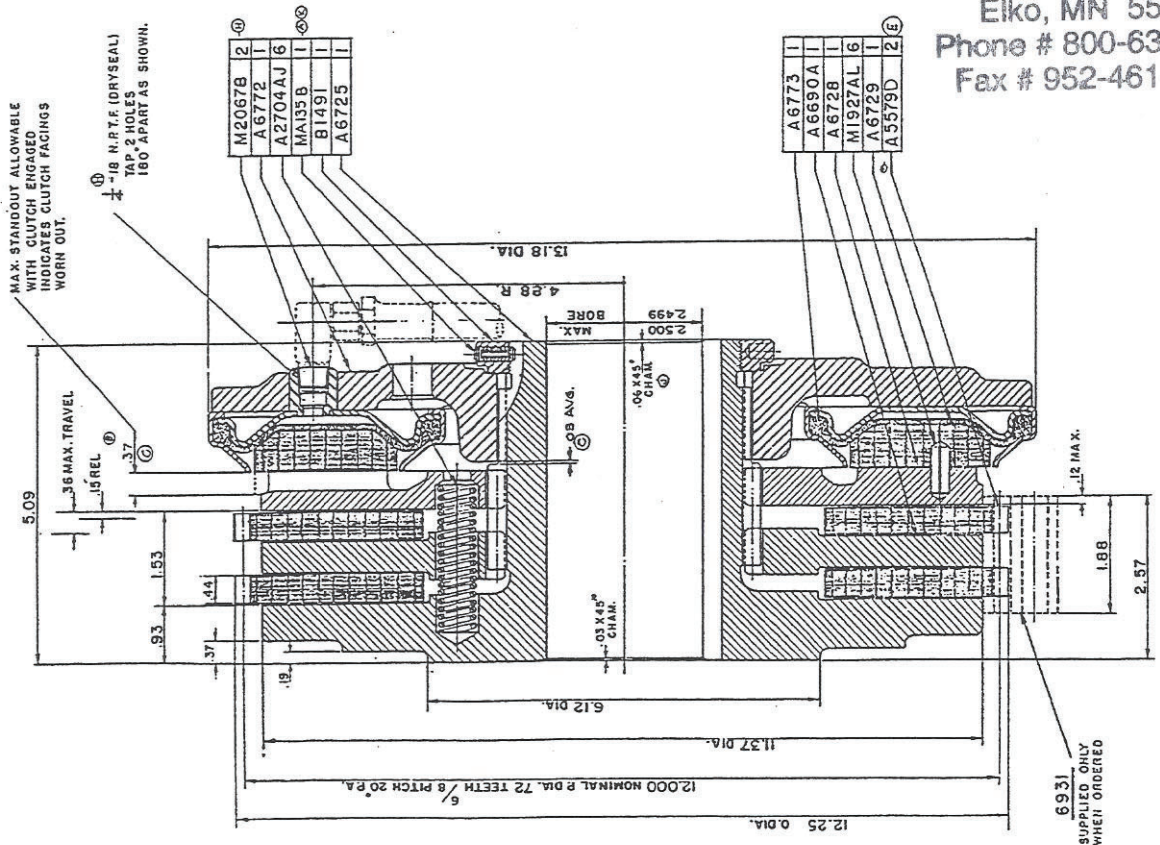

M2067B	2	②
A6772	1	
A2704AJ	6	③
MA135B	1	④
B1491	1	
A6725	1	

A6773	1	⑤
A6690A	1	
A6728	1	
M1927AL	6	
A6729	1	
A5579D	2	⑥

N.D.S. Drilling Supply
26041 Newton Circle
Elko, MN 55020
Phone # 800-637-1940
Fax # 952-461-3403

6931
SUPPLIED ONLY
WHEN ORDERED

DATE	REV	BY	CHKD
10/11/81	1
10/11/81	2
10/11/81	3
10/11/81	4

SEE X 9710 FOR AVAILABLE SPIDERS

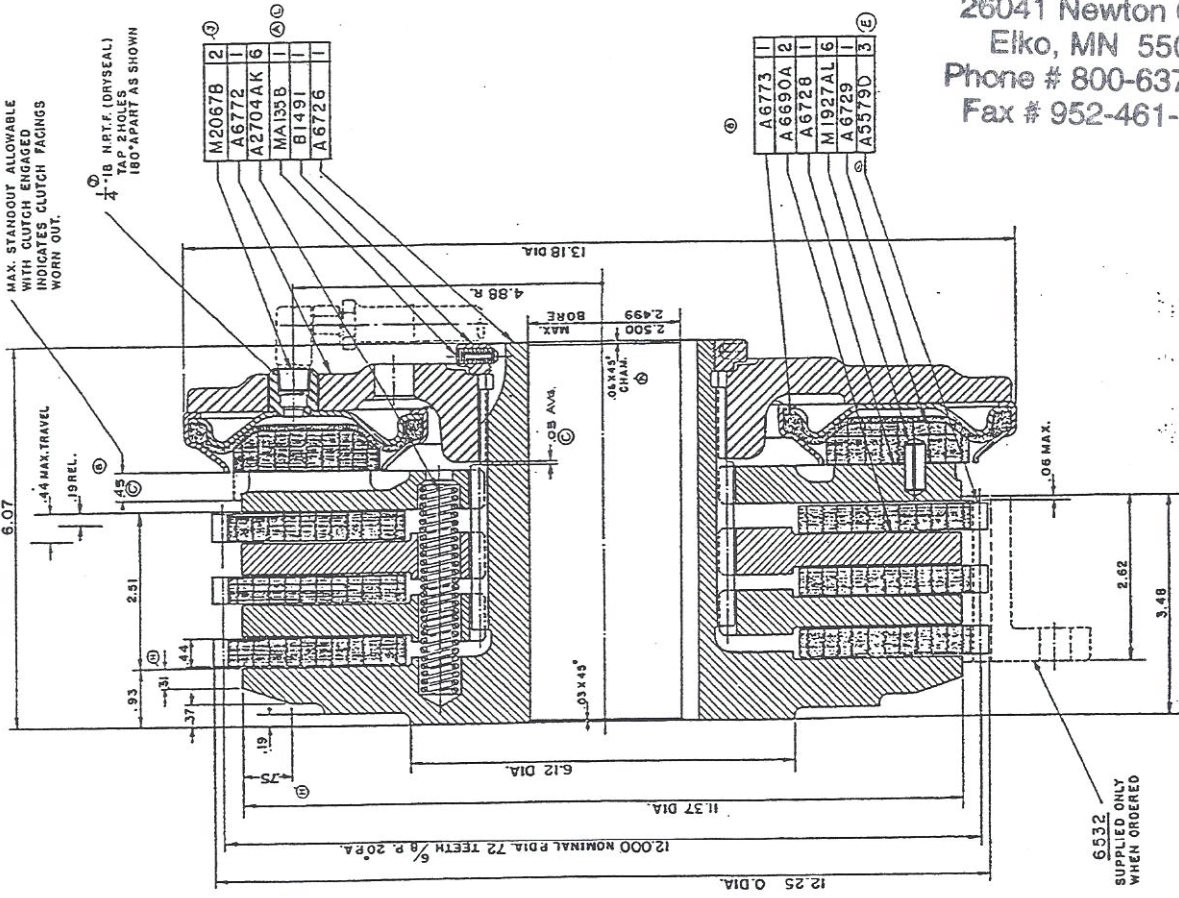

MAX. STANDBY ALLOWABLE WITH CLUTCH ENGAGED. INDICATES CLUTCH FACINGS WORN OUT.

1/4" ID. N.P.T.F. (DRYSEAL) HOSE AND FITTINGS. 180° PART AS SHOWN

M2067B	2
A6772	1
A2704AK	6
MA135B	1
BI491	1
A6726	1

A6773	1
A6690A	2
A6728	1
M1927AL	6
A6729	1
A3579D	3

CUSTOMER TO SUPPLY HOSE AND FITTINGS. S.A.E. 40 R-2 QUALITY, UNLESS TESTS WARRANT TUBING.

NOTE: AIR INLET HOLES MUST BE ASSEMBLED IN LINE WITH THE KEYWAY AS SHOWN (WITHIN 7 1/2°)

N.D.S. Drilling Supply
26041 Newton Circle
Elko, MN 55020
Phone # 800-637-1940
Fax # 952-461-3403

6532 SUPPLIED ONLY WHEN ORDERED

SEE SHEET 1, 2, 3 FOR LIMITING CONDITIONS AND MAX. SPEEDS

PATENT APPLIED FOR PO 311 AIR CLUTCH

NOTICE: THIS PART CONTAINS PROPRIETARY INFORMATION AND IS NOT TO BE REPRODUCED OR TRANSMITTED IN ANY FORM OR BY ANY MEANS, ELECTRONIC OR MECHANICAL, INCLUDING PHOTOCOPYING, RECORDING, OR BY ANY INFORMATION STORAGE AND RETRIEVAL SYSTEM, WITHOUT THE WRITTEN PERMISSION OF THE U.S. GOVERNMENT OR THE ORIGINAL SOURCE OF THE INFORMATION.

SEE X9716 FOR AVAILABLE SPIDERS

TWIN DISCS
X9711

1	2	3	4	5	6	7	8	9	10	11	12	13	14	15	16	17	18	19	20	21	22	23	24	25	26	27	28	29	30	31	32	33	34	35	36	37	38	39	40	41	42	43	44	45	46	47	48	49	50	51	52	53	54	55	56	57	58	59	60	61	62	63	64	65	66	67	68	69	70	71	72	73	74	75	76	77	78	79	80	81	82	83	84	85	86	87	88	89	90	91	92	93	94	95	96	97	98	99	100
---	---	---	---	---	---	---	---	---	----	----	----	----	----	----	----	----	----	----	----	----	----	----	----	----	----	----	----	----	----	----	----	----	----	----	----	----	----	----	----	----	----	----	----	----	----	----	----	----	----	----	----	----	----	----	----	----	----	----	----	----	----	----	----	----	----	----	----	----	----	----	----	----	----	----	----	----	----	----	----	----	----	----	----	----	----	----	----	----	----	----	----	----	----	----	----	----	----	----	-----